

ROOFING APPLICATION STANDARD (RAS) No. 109-A Detail Drawings

The following guide details have been provided by the Polyurethane Foam Contractors Division of The Society of the Plastics Industry, Inc. for application guidelines.

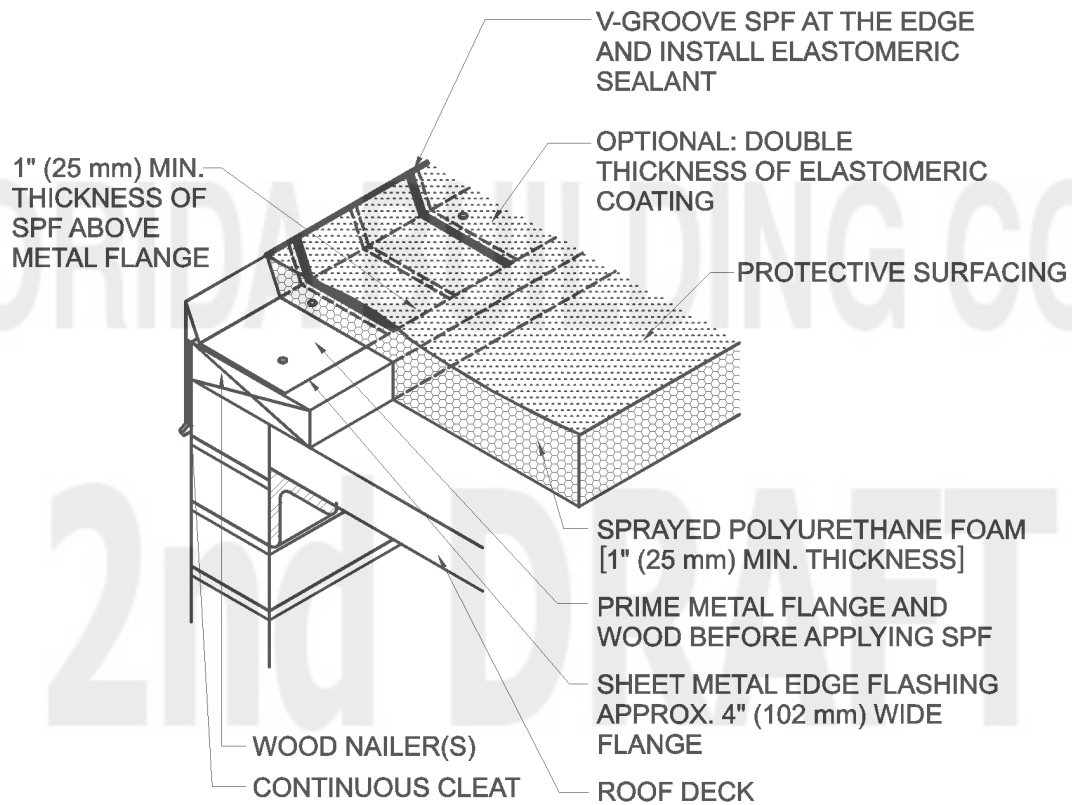

DETAIL 1

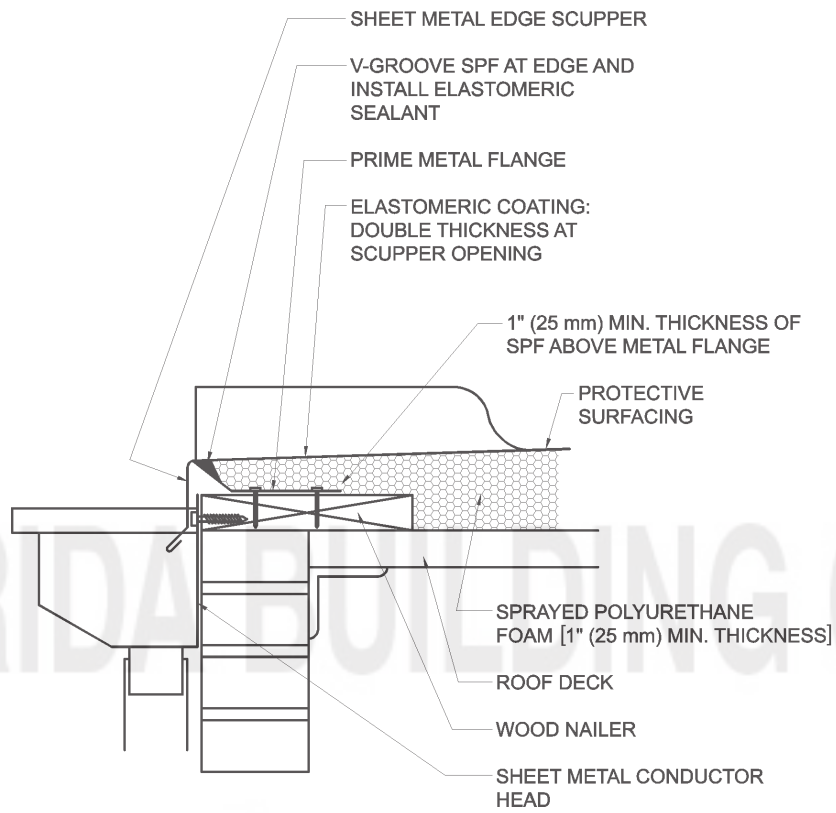

DETAIL 2

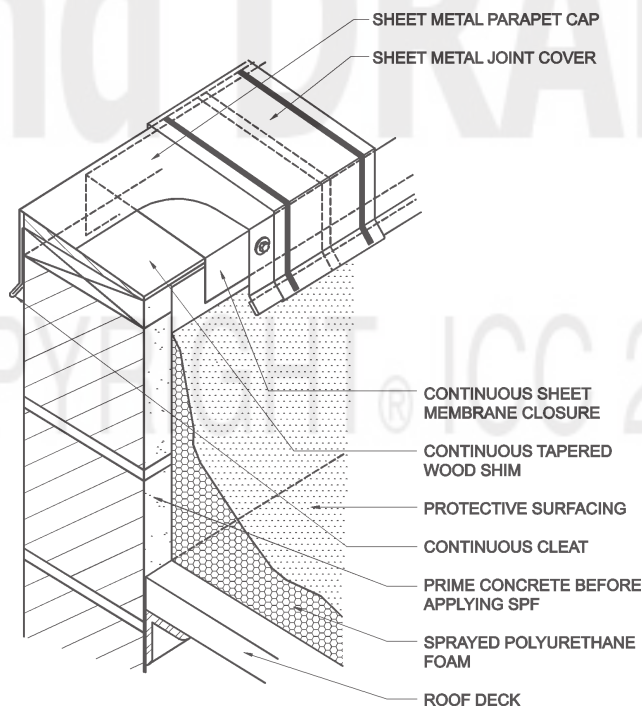

DETAIL 3

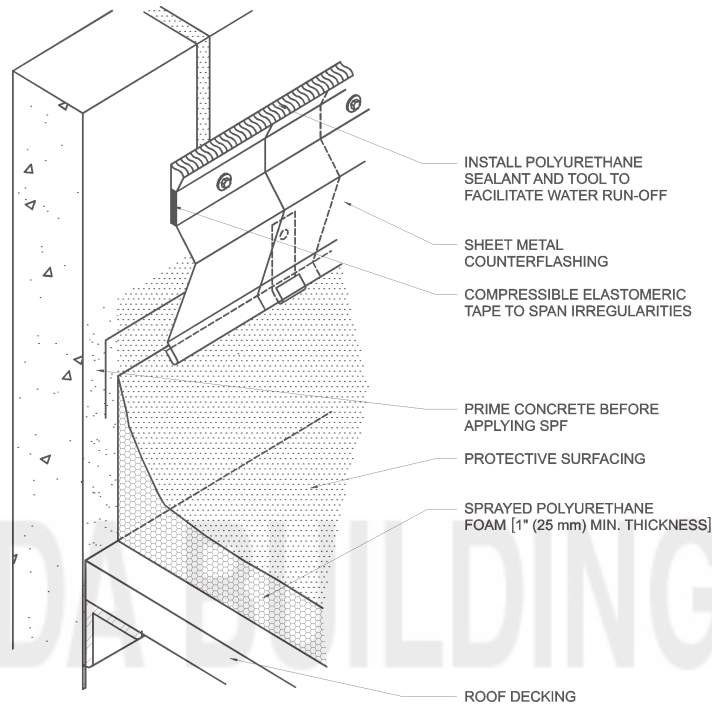

DETAIL 4

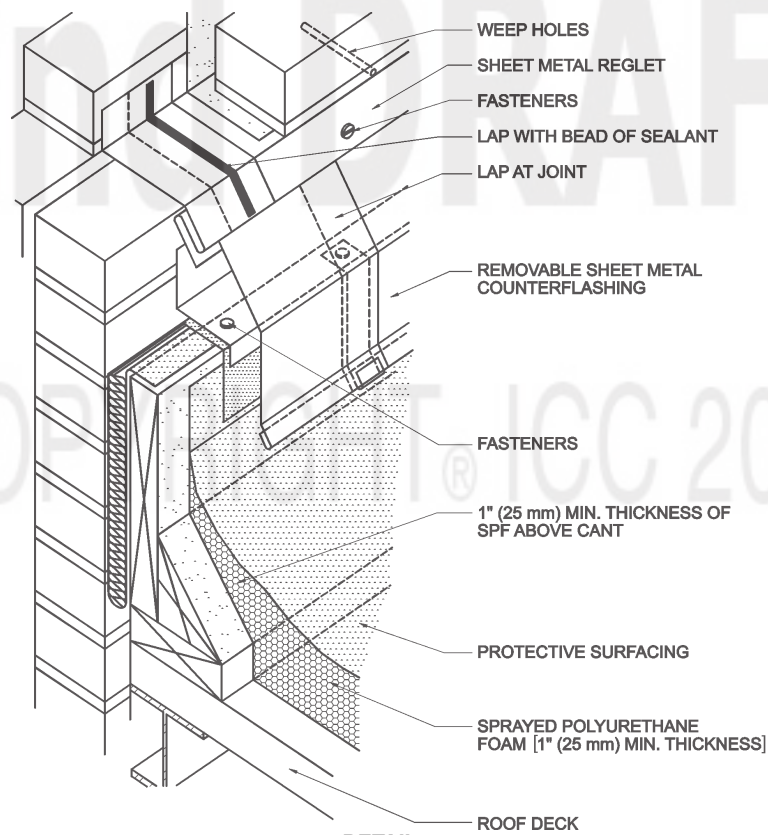

DETAIL 5

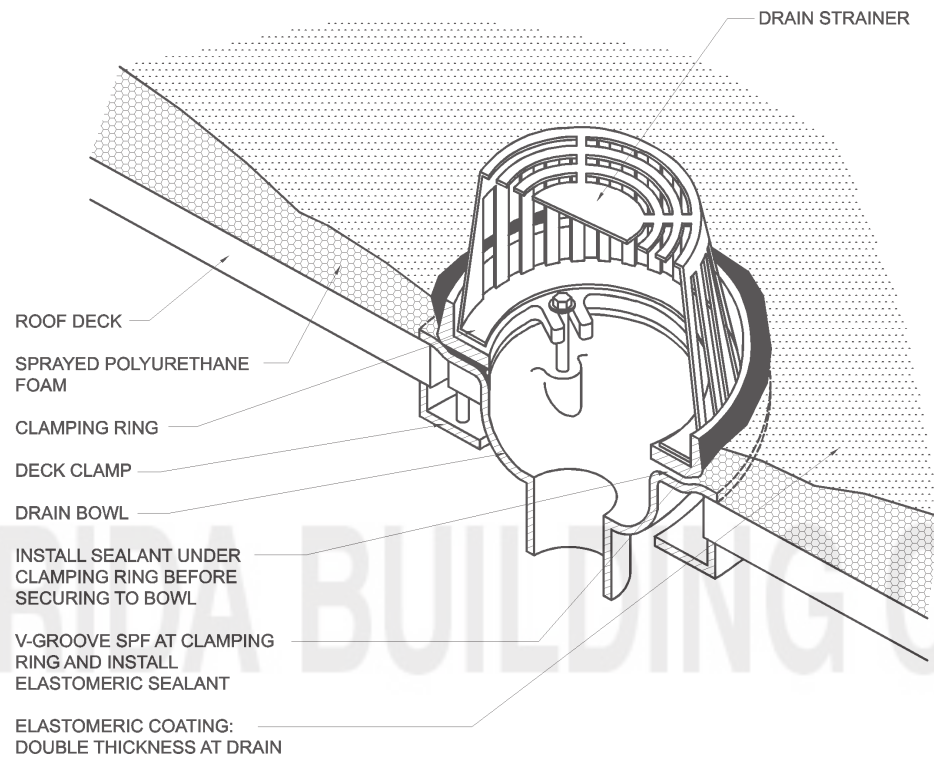

DETAIL 6

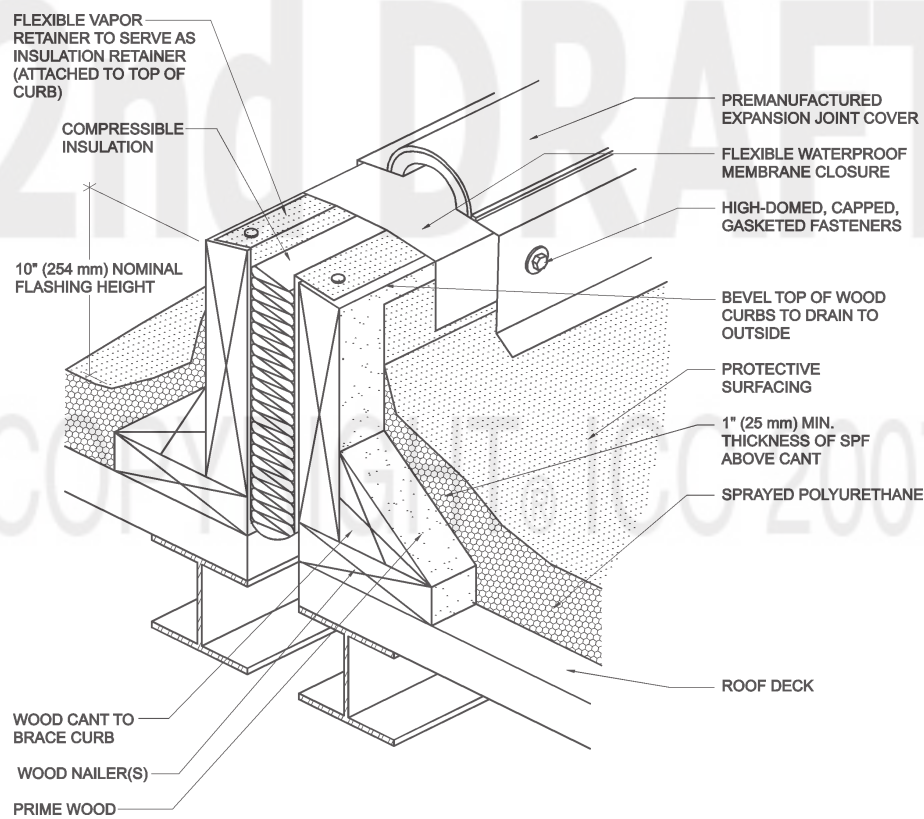

DETAIL 7

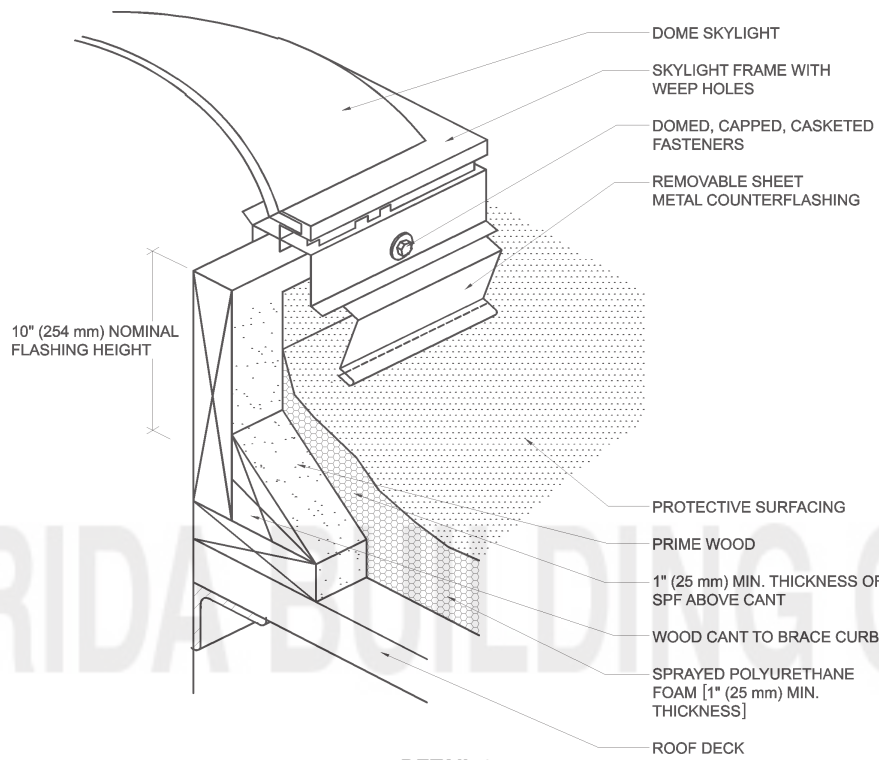

DETAIL 8

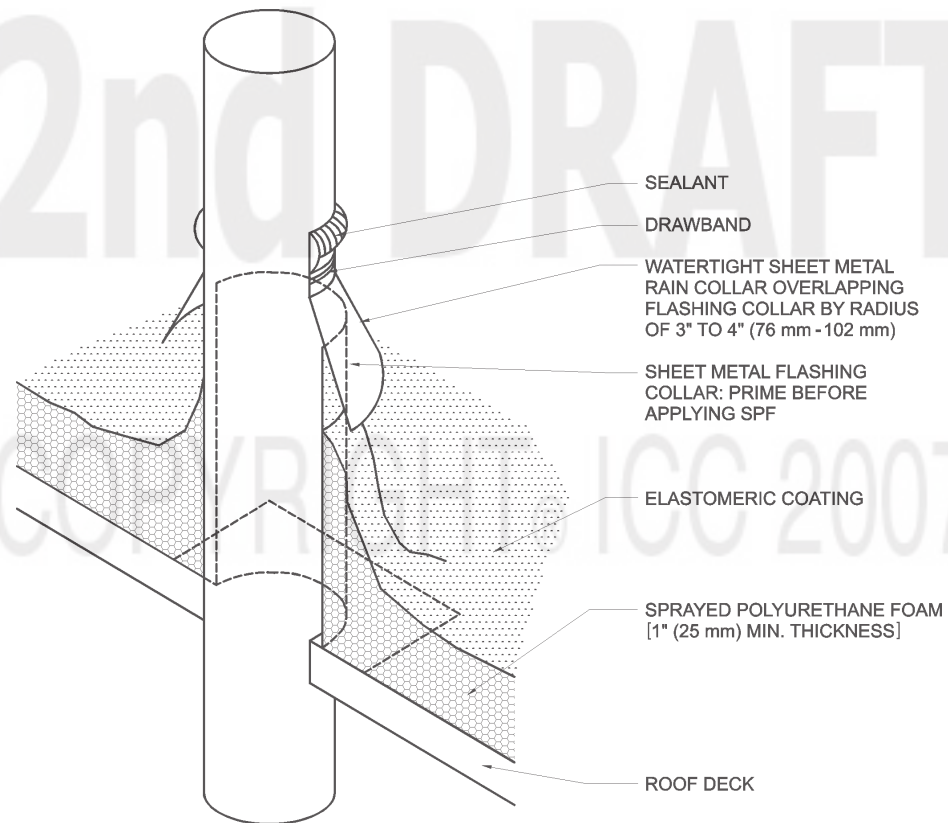

DETAIL 9

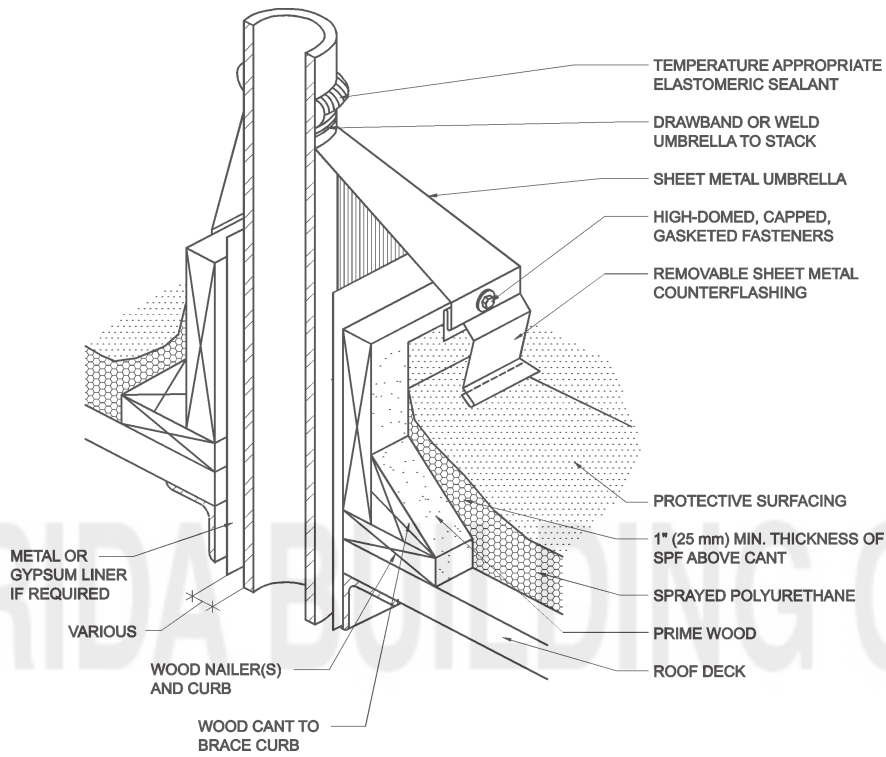

DETAIL 10

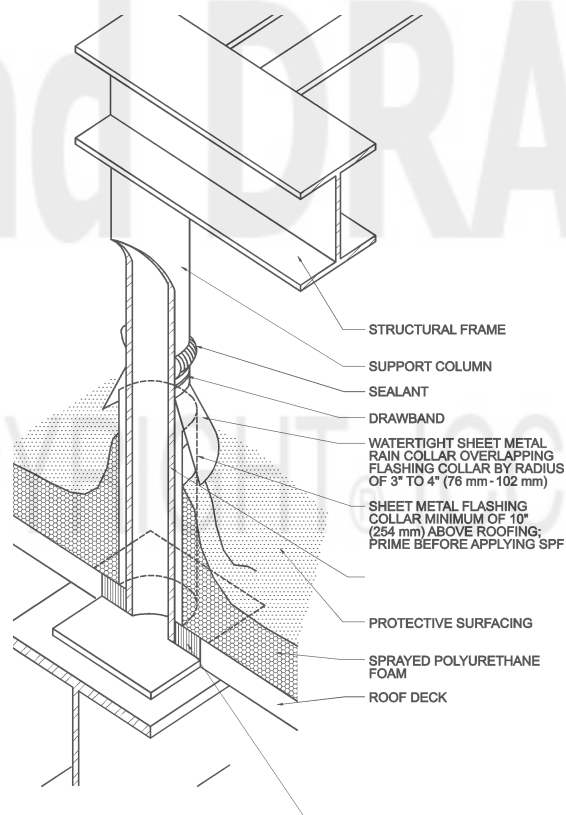

DETAIL 11