

## ROOFING APPLICATION STANDARD (RAS) No. 133

### STANDARD PROCEDURE FOR INSTALLATION OF METAL ROOF SYSTEMS

#### 1. Scope

- 1.1 This application standard has been developed to provide consistent information for the installation and uses of metal roof systems.
- 1.2 This application standard determines the options for specific flashing conditions and provides guidelines for application in compliance with Product Approval.
- 1.3 This application standard describes various flashing methods that can be used to terminate metal roof assemblies.

#### 2. Definitions

- 2.1 For definitions of terms used in this application standard, refer to ASTM D 1079; and the *Florida Building Code, Building*.

#### 3. General Requirements

- 3.1 All perimeter flashings shall meet the material sizing and attachment requirements set forth RAS 111.
- 3.2 Underlayment shall be in accordance with Chapter 15 (High-Velocity Hurricane Zones) of the *Florida Building Code, Building*.

#### 4. Specific Metal Roof System Assembly Types and Related Requirements

- 4.1 Metal roofing panels shall comply with the minimum test requirements set forth below:

Accelerated Testing of Coating	ASTM G 23 (2000 hours)
Salt Spray Testing of Coating	ASTM B 117 (1000 hours)

- 4.2 Roof System Assemblies utilizing concealed clips shall be installed with clips of the size, material, gage and markings specified in the metal roofing Product Approval. No substitutions shall be allowed.

- 4.3 Sealants, closure strip and accessory components shall be as specified in the metal roofing Product Approval.

#### 5. Design Considerations

- 5.1 Metal panel continuous lengths shall not exceed 45 feet for steel and stainless steel and 32 feet for aluminum, copper and monel.

- 5.2 Clips, cleats and/or fastening points shall be as detailed in the metal roofing Product Approval. All field fabricated cleats shall have two approved nails or fasteners in each, protected by a foldover tab (see Figure 1, below). Cleats shall be fabricated from materials listed in the metal roofing Product Approval.

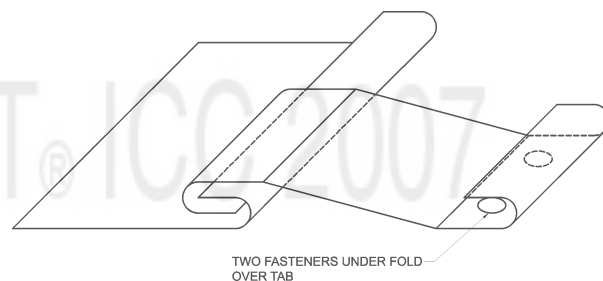

FIGURE 1  
EXAMPLE OF PANEL CLEAT

5.3 All components shall be of compatible material.

5.4 Maximum design pressures listed in the metal roofing Product Approval shall meet or exceed design pressures for the field area of the roof determined in compliance with the *Florida Building Code, Building*. Design pressures for perimeter and corner areas may be increased through data extrapolation.

5.4.1 All extrapolation of data shall be signed and sealed by a registered architect or a professional engineer must be submitted with the uniform roofing permit application.

5.5 Woodblocking

5.5.1 All woodblocking installed to secure or support metal roofing panels shall be in compliance with the American Wood Preservers Association salt pressure treating specification C-2 or C-9.

5.5.2 All woodblocking shall be secured to the substrate in compliance with RAS 111.

**6. Sealants and Closure Strips**

6.1 Closure strip shall be cut or fabricated to snugly fit the metal profile creating an efficient seal. Closure strip shall be bonded in place with a continuous bead of approved sealant, top and bottom, to eliminate movement or the potential of dislodging. Joints in the closure strip shall be tight.

**7. Perimeters**

7.1 Eaves may be terminated with a drip edge flashing (see Figure 4) or a gutter at the transition with a side wall. Refer to material and application methods for fabrica-

tion, attachment, and sizing set forth in RAS 111.

7.2 Metal profiles shall be closed at eave conditions with closure strip, sealant or metal caps to create a watertight closure.

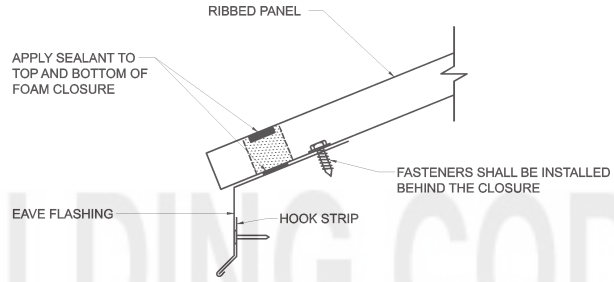

**FIGURE 2  
TYPICAL EAVE TERMINATION DETAIL WITH CLOSURE STRIP**

7.3 Rake and Rake Wall

7.3.1 Rake wall flashings are base flashings where a metal Roof System Assembly abuts a vertical wall at a slope condition (see Figure 3). The flashing shall provide a waterproofing bridge between the metal Roof System Assembly and the vertical wall.

7.3.1(a) Rake wall flashings shall terminate at the high point of the panel or a transition joint shall be formed to avoid waterflow at the metal transition.

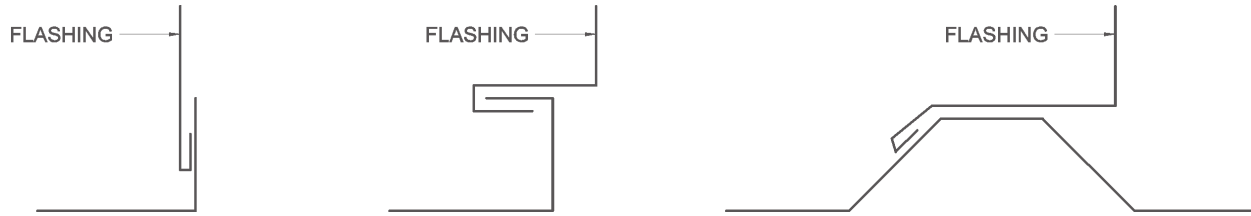

FIGURE 3  
TYPICAL PROFILES OF RAKE WALL FLASHINGS

FLORIDA BUILDING CODE

7.3.2 Rake flashings are perimeter flashings at the sloping edge of the metal Roof System Assembly, usually terminated with a drip edge or gravel stop flashing (see Figure 4, below). Rake flashings shall be fabricated from materials, sized and attached in compliance with RAS 111.

7.3.2(a) Rake flashings shall terminate at the high point of the panel as detailed in 7.3.1(a).

7.4 Ridge, hip and headwall flashings shall be formed of metal in combination with woodblocking, metal or closure strip material and fastening devices.

2nd DRAFT

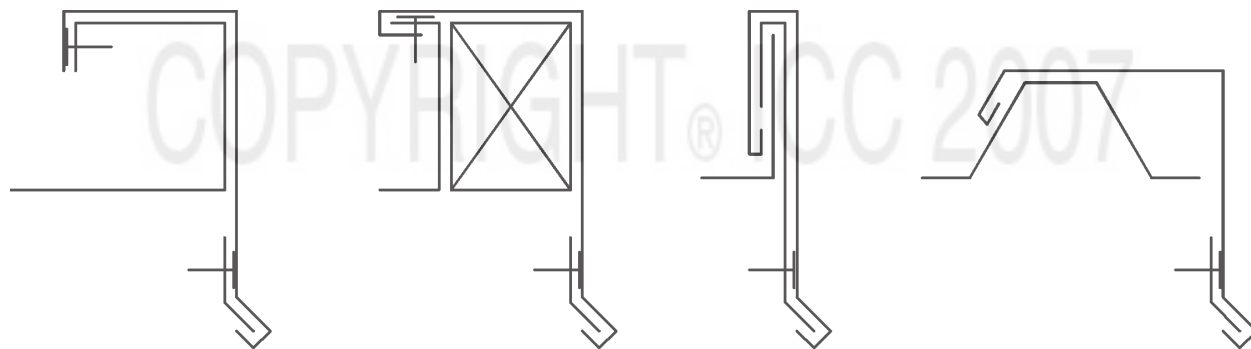

FIGURE 4  
TYPICAL RAKE PROFILES

- 7.4.1 All panels shall be turned up at terminations to create a water stop. If the metal profile is too rigid or the vertical metal will not allow for a bend, the pans shall be notched and turned up with sealant applied at all cuts and openings.
- 7.4.2 All end panels shall be closed with a metal roof pan closure strip or a closure strip bonded into place. (see Section 8.9, herein).
- 7.4.3 End and ridge closures shall be designed to resist water blow back as well as vermin and insect entry.

**8. Penetrations**

- 8.1 All metal overlaps shall be formed to shed water. Laps of rectangular shaped penetration flashings over panels (for lower elevations) or under panels (for higher elevations) shall be a minimum of 12 in.

and shall have a continuous double row of approved sealant applied.

- 8.1.1 Side laps at the edge of base panels shall occur on ribs or seams and shall be sealed with a continuous double row of approved sealant.
- 8.1.2 Drainage clearance troughs shall be provided between a rectangular penetration flashing and the ends of interrupted ribs at the high side of the flashing. When the width of the rectangular flashing exceeds 18", or is greater than one pan width of the roof panel, a cricket shall be installed to direct water flow away from the penetration. (See Figure 6, below.)

- 8.2 Penetration flashings shall be designed to move with the metal roof panels during periods of expansion and contraction. The metal roofing system, in conjunction with the penetration flashings, must move without causing failure of the transition joints. (see Figures 7 and 8, below).

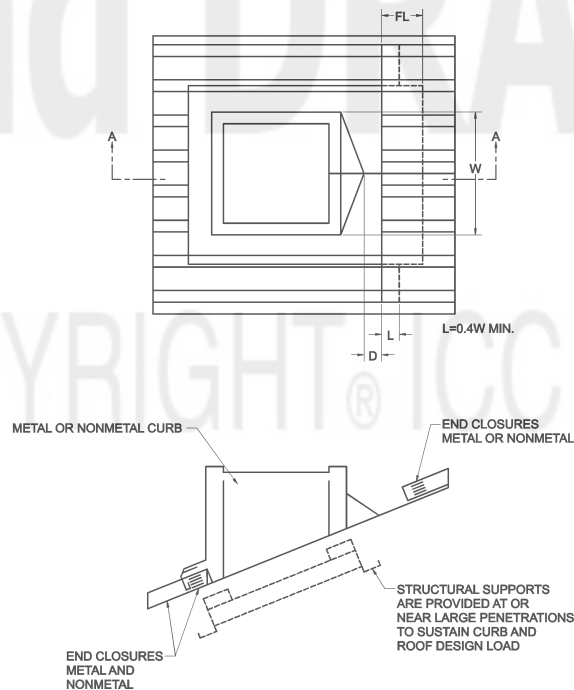

**FIGURE 6  
TYPICAL CURB FLASHING**

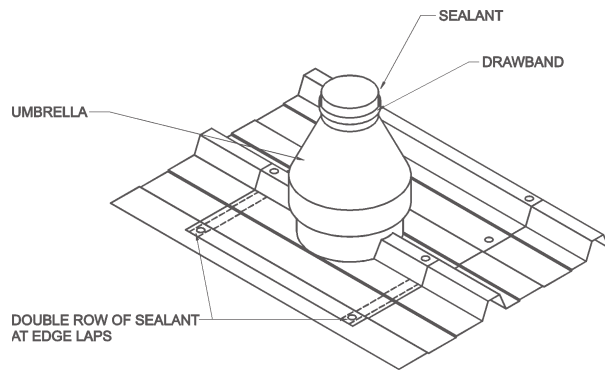

FIGURE 7A  
PENETRATION FLASHING

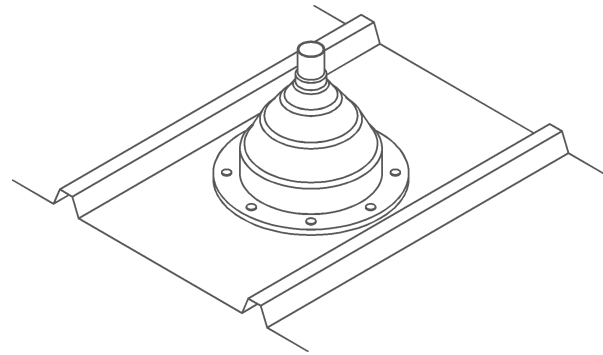

FIGURE 8  
ELASTOMERIC FLASHING

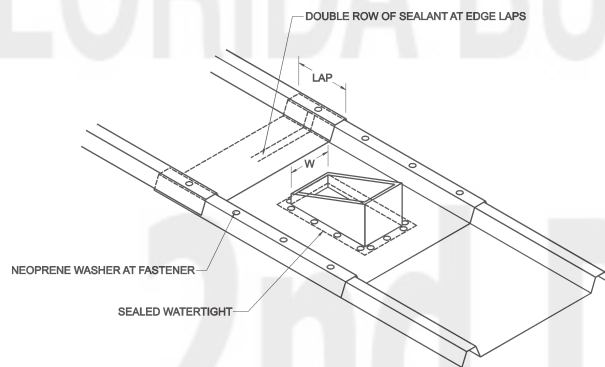

FIGURE 7B  
PENETRATION FLASHING

9.1.2 Panels shall be secured at the valley by:

9.1.2(a) a hold down cleat at the transition with the valley (see Figure 9, above); or

9.1.2(b) fasteners penetrating through the panel to the structural members or sheeting below; or

9.1.2(c) other method defined in the Product Approval for the metal Roof System Assembly.

9. Transitions

9.1 Valley Flashings

9.1.1 Valley flashings shall be fabricated from materials that are the same or are compatible with the roof panel system, and not less than the gage of the metal panel. Valleys must be supported by underlying decking (for non-structural systems) or by structural members running the length of the valley (for structural systems).

9.1.3 Cleated panels are required for concealed fastener systems such as standing seam.

9.1.3(a) The cleats shall be set in a bead of sealant and fastened 6 in. o.c. with a pan head screw on prefinished metals. Alternatively, cleats may be soldered in place when using corrosion resistant metals.

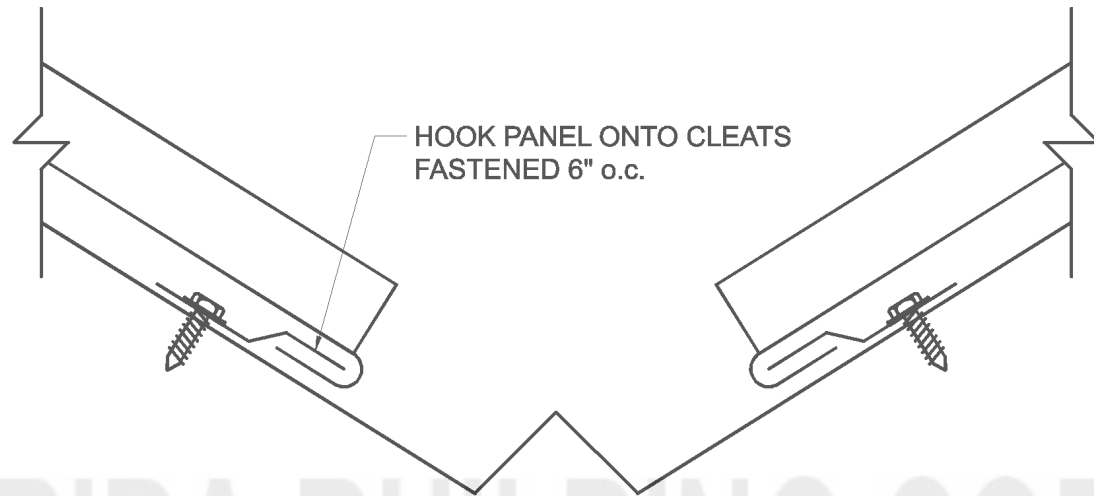

CLEATS SET IN APPROVED SEALANT OR  
PREFINISHED METAL OR SOLDER TO  
NON-FERROUS METALS

FIGURE 9  
RECOMMENDED STANDING SEAM VALLEY

- 9.1.4 Mechanically fastened panels shall be secured at the valley transition (see Figure 10.)
- 9.1.5 Panels shall lap a minimum of 3 in. over the valley while maintaining a minimum 6 in. drainage channel.
- 9.1.6 All valley flashing endlaps shall be a minimum of 6 in. and shall be mechanically fastened and sealed.
- 9.2 Details shown in the *Architectural Sheet Metal Manual*, as published by SMACNA, as adopted by the *Florida Building Code, Building* are acceptable.

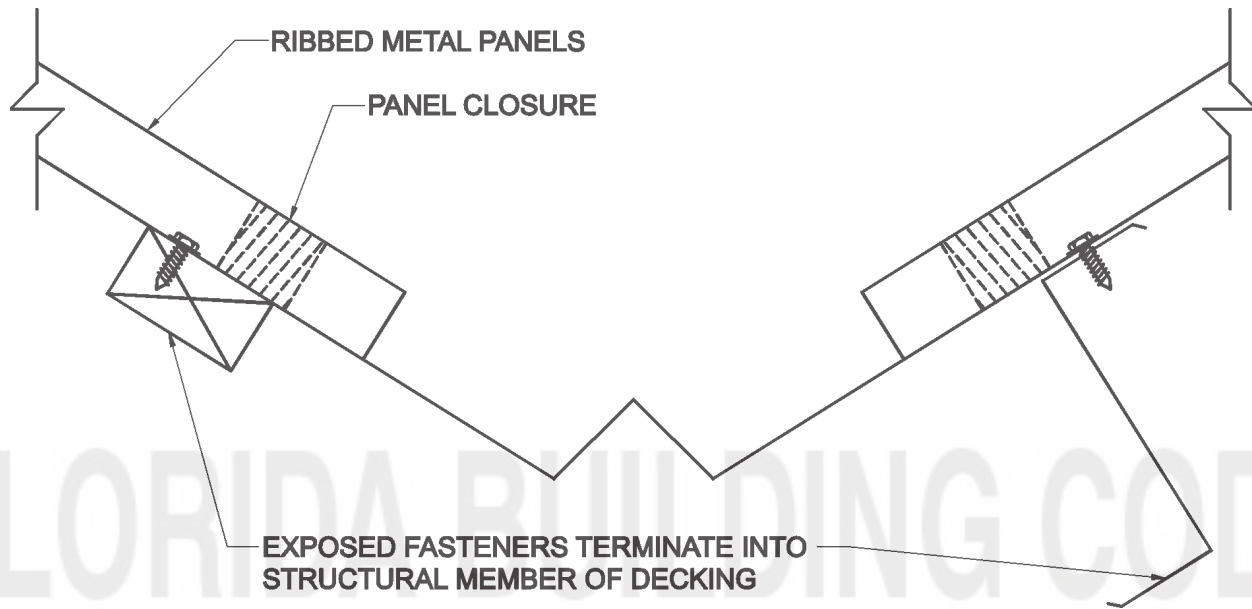

FIGURE 10  
RIBBED PANEL VALLEY

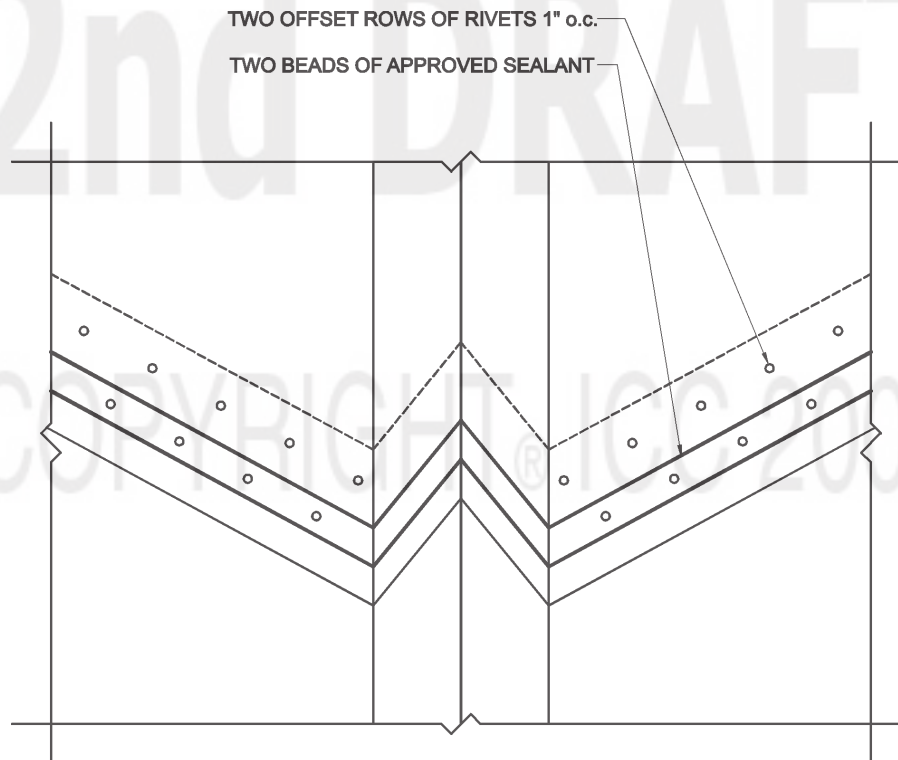

FIGURE 11  
SEALED LOW SLOPE VALLEY LAP

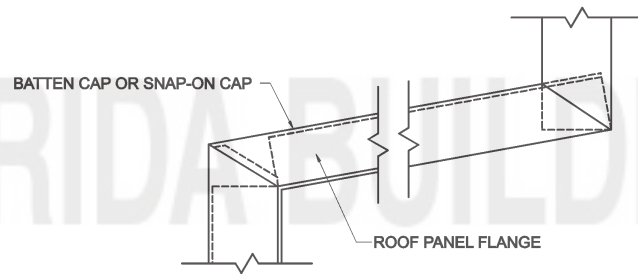
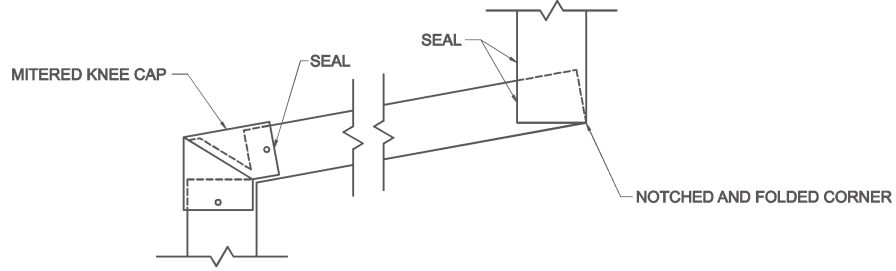

FIGURE 12  
TRANSITION WITH KNEE BENDS

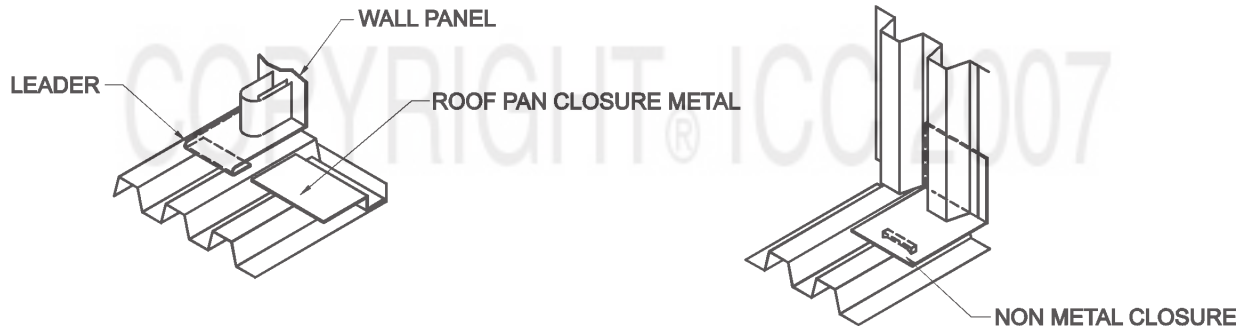
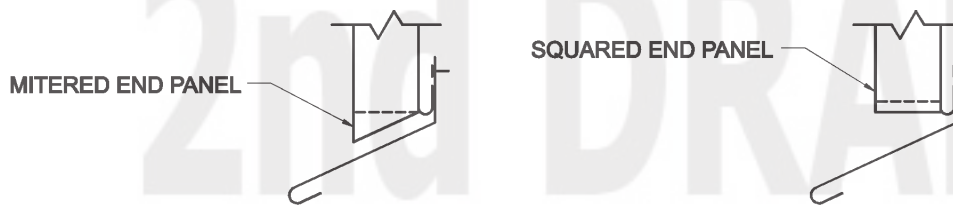

FIGURE 13  
TRANSITION FLASHINGS AT HEADWALL CONDITION