

## TESTING APPLICATION STANDARD (TAS) 117(C)-95

### TEST PROCEDURE FOR DYNAMIC PULL-OFF PERFORMANCE OF ROOFING FASTENER HEADS OR FASTENERS WITH BEARING PLATES

#### 1. Scope:

- 1.1 This protocol covers determination of the dynamic pull-off performance of roofing fastener heads or fasteners with bearing plates.
- 1.2 This protocol is applicable to both metal and plastic bearing plates. Metal bearing plates shall also be tested for dynamic pull-through resistance with roofing membranes in compliance with TAS 117(B).
- 1.3 The test procedures outlined herein utilize a dynamic eccentric loading procedure.
- 1.4 All testing and calculations shall be conducted by a certified testing agency and all test reports, including calculations, shall be signed and sealed by a professional engineer or registered roof consultant.

#### 2. Referenced Documents:

- 2.1 *The Florida Building Code, Building*
- 2.2 *Application Standards:*
  - TAS 117(B) Test Procedure for Dynamic Pull-Through Performance of Roofing Membranes Over Fastener Heads or Fasteners with Metal Bearing Plates
- 2.3 *Norwegian Building Research Institute: Roofing Systems with Mechanical Attachments*
- 2.4 *ASTM Standards:*
  - D 1079 Standard Definitions and Terms Relating to Roofing, Waterproofing and Bituminous Materials
  - E 380 Excerpts from the Standard Practice for Use of the International System of Units (SI) (the Modernized Metric System)

#### 3. Terminology & Units:

- 3.1 Definitions—For definitions of terms in this Protocol, refer to Chapter 2 and Section 1513 of the *Florida Building Code, Building* and ASTM D 1079. The definitions from the *Florida Building Code, Building* shall take precedence.

3.1.1 All references to “bearing plate” are interchangeable with “stress plate.”

3.1.2 The dynamic pull-off value under dynamic eccentric loading shall be defined as the mean load capacity obtained at failure. Failure shall be defined as any of the following:

- breakage of the stress plate;
- pull through of the fastener head in the stress plate; or,
- permanent deformation of the fastener, fastener head or stress plate in excess of  $\frac{1}{4}$  inch (6.3 mm).

- 3.2 Units—For conversion of U.S. customary units to SI units, refer to ASTM E 380.

#### 4. Significance and Use:

4.1 The test procedure provides a means of determining of the dynamic pull-off performance of roofing fastener assemblies when exposed to dynamic eccentric loading.

4.2 The test procedure is acceptable for all types of fasteners with integral bearing plates and fasteners with separate bearing plates.

Note: Roofing nails or cap nails are not approved for use within the high-velocity hurricane zone jurisdiction. therefore, results from testing these nail types shall not be utilized as design values for projects within this jurisdiction. In addition, the minimum and maximum bearing plate diameters for anchor or base sheet attachment within the high-velocity hurricane zone jurisdiction

are  $1\frac{7}{8}$  inches (41 mm) and 2 inches (51 mm), respectively. Therefore, results from testing bearing plates having a diameter less than  $1\frac{7}{8}$  inches (41 mm) or greater than 2 inches (51 mm) shall not be utilized as design values for projects within this jurisdiction.

## 5. Sampling:

- 5.1 Fastener and/or bearing plate samples shall be provided directly from the respective manufacturer and shall be tested as delivered. Unless otherwise specified, 14 samples shall be tested for each variable in the test specimen (i.e. different fastener or different bearing plate).

## 6. Test Method:

### 6.1 General:

- 6.1.1 The dynamic pull-off value is determined by subjecting the test specimen to a dynamic eccentric loading.

### 6.2 Apparatus

- 6.2.1 The test apparatus is shown in Figures 1, 4 and 5, attached.
- 6.2.2 A wire reinforced test strap (See Figures 2 and 3, attached). The test strap shall consist of a 0.08 inch (2 mm) diameter steel wire welded between two plies of 0.05 inch (1.2 mm) PVC membrane reinforced with polyester fabric. At the point of contact in the wire loop, an additional ply of membrane shall be wrapped around the wire to avoid cutting action on the fastener.
- 6.2.3 Attachment cables having varying lengths for various drop heights.
- 6.2.4 Drop weights having a mass of 5 pounds (2.3 kg).
- 6.2.5 A device to measure, reference and mark the height of drop.

### 6.3 Preparation of test samples:

- 6.3.1 The fasteners shall not be prepared in any way; however, care shall be taken to insure that fasten-

ers are mounted in the test specimen in a defined, consistent manner.

- 6.3.2 The fastener assembly sample shall be installed through the center of the test apparatus as shown in Figure 1, attached.

- 6.3.3 Dynamic pull-through testing shall be conducted in a room with controlled temperature and humidity, 73°F ( $23 \pm 2^\circ\text{C}$ ) and RH 50 percent.

### 6.4 Procedure:

- 6.4.1 The fastener assembly test specimen shall be mounted in the test apparatus to insure no fastener withdrawal will occur upon loading.

- 6.4.2 The dynamic load shall be applied as follows:

- *Fixed drop height:*

The fastener assembly shall be subjected to a dynamic impact load with the drop weight being released from a fixed drop height to the nearest 1 inch.

- *Intervals of increasing drop heights:*

The fastener assembly shall be subjected to dynamic impact loads of increasing intensity with the drop weight being released from increasing drop heights at intervals of 3 inches (100 mm) until failure occurs.

Application of a dynamic impact load from a fixed drop height shall only be considered if the fastener assembly has previously been tested and the intent is to upgrade the fastener assembly pull-off value. The datum point of drop height shall then be the previous test result.

### 6.5 Interpretation of results:

- 6.5.1 Table 1 below lists the corresponding fastener assembly

pull-off values which relate to respective drop heights. These values shall be recorded upon completion of testing and shall be statistically analyzed, as noted in Section 6.6, herein.

**TABLE 1  
FASTENER ASSEMBLY PULL-OFF VALUES  
VS. DROP HEIGHT**

Drop Height (ft)	Pull-Off Value (lbf)
4	20
5	25
6	30
7	35
8	40
9	45
10	50
11	55
12	60
13	65
14	70

For SI: 1 foot = 304.8 mm.

#### 6.6 Statistical analysis of results:

6.6.1 Eliminate the 'high' and 'low' values recorded during the dynamic pull-off testing and calculate a mean and a standard deviation from the remaining 12 recorded values using the following equations.

$$\bar{F} = \frac{1}{12} \sum_{i=1}^{12} F_i$$

$$S_F = \sqrt{\frac{1}{11} \sum_{i=1}^{12} (F_i - \bar{F})^2} \quad \text{where,}$$

$\bar{F}$  = mean load;

$S_F$  = standard deviation;

$F$  = record load; and,

$i$  = test number

6.6.2 Determine the percent deviation from the mean ( $S'_F$ ) using the following equation.

$$S'_F = \left( \frac{S_F}{F} \right) \times 100$$

If the percent deviation from the mean ( $S'_F$ ) is greater than 35 percent, then the test results shall be considered null and void and

the dynamic pull-off performance under dynamic eccentric loading shall be retested.

## 7. Report:

7.1 The final test report shall include the following relevant information:

7.1.1 Name and address of the testing laboratory.

7.1.2 Identification number of the test report.

7.1.3 Name and address of the organization or the person who ordered the test.

7.1.4 Purpose of the test.

7.1.5 Method of sampling and other circumstances (date and person responsible for the sampling).

7.1.6 Name and address of manufacturer or supplier of the tested object(s).

7.1.7 Name or other identification marks of the tested object(s).

7.1.8 Description of the tested object(s).

7.1.9 Date of supply of the tested object(s).

7.1.10 Date of the test.

7.1.11 Test method.

7.1.12 Conditioning of the test specimens, environmental data during the test (temperature, pressure, RH, etc.).

7.1.13 Identification of the test equipment and instruments used.

7.1.14 Any deviations from the test method.

7.1.15 Test results and statistical analysis computations.

7.1.16 Date and signature.

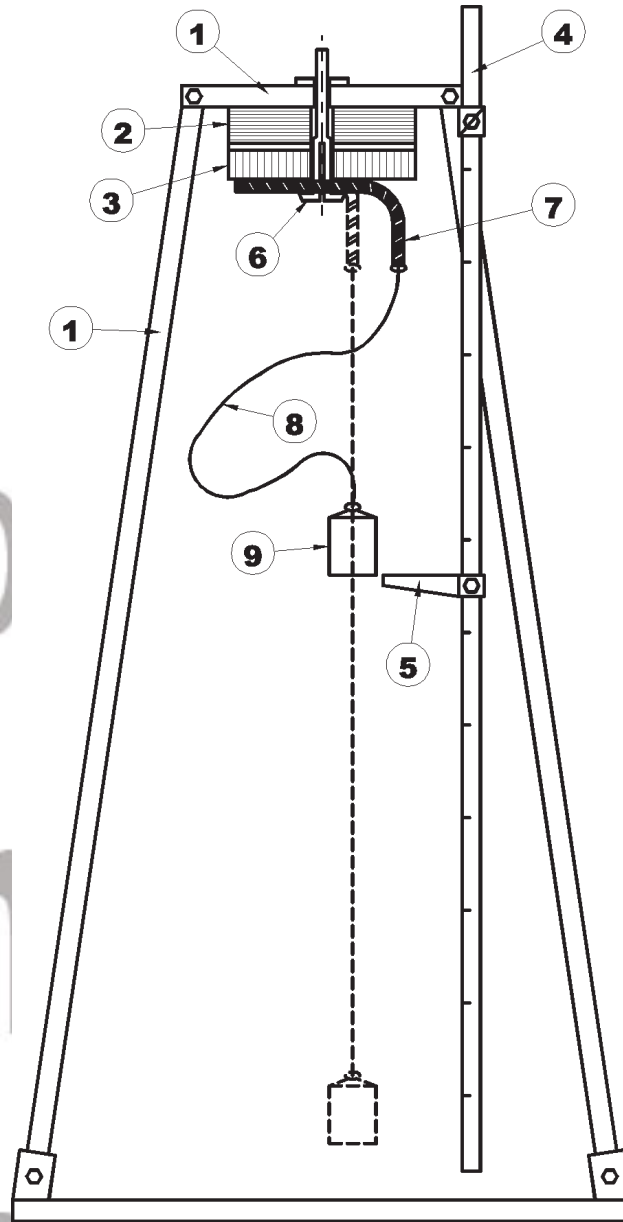

FIGURE 1  
DIAGRAM OF DYNAMIC PULL-OFF TEST APPARATUS

1. Steel Frame
2. 1<sup>3</sup>/<sub>4</sub>-inch (45 mm) rubber pad
3. 2-inch (50 mm) wood plank
4. Drop height measurement device
5. Drop height reference indicator
6. Fastener assembly test specimen
7. Test strap
8. Steel wire of appropriate length
9. Drop weight

For SI: 1 inch = 25.4 mm.

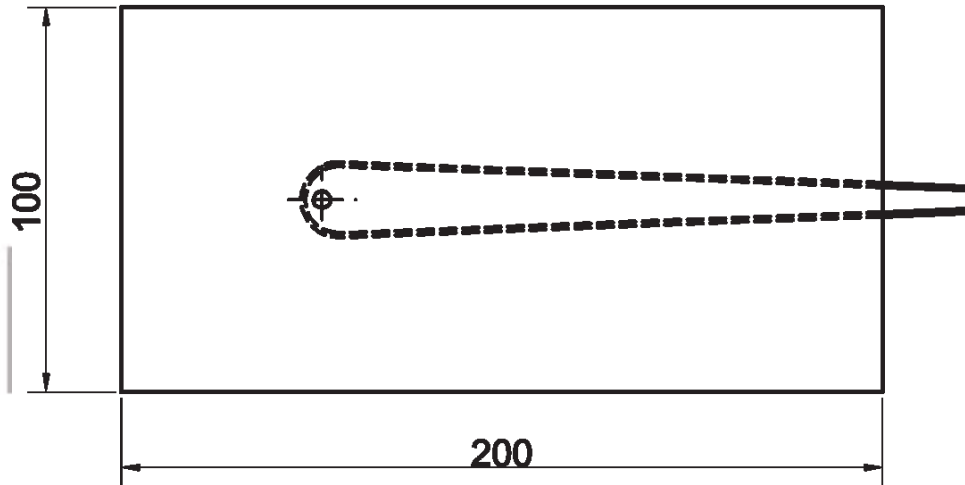

FIGURE 2  
DIAGRAM OF WIRE REINFORCED TEST STRAP

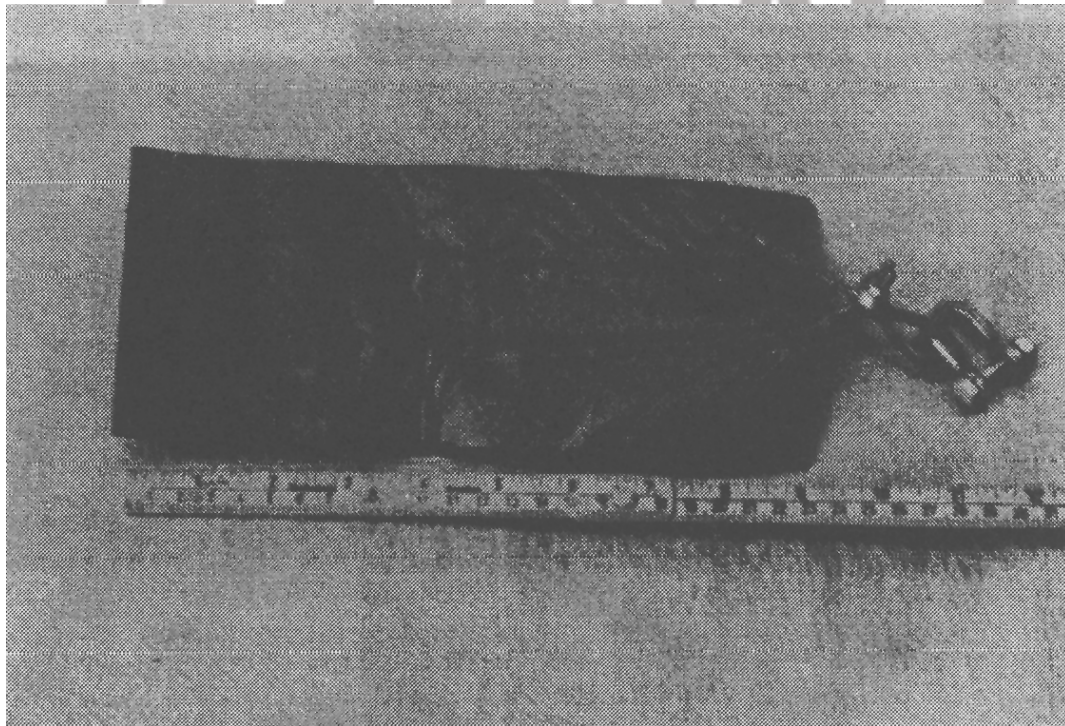
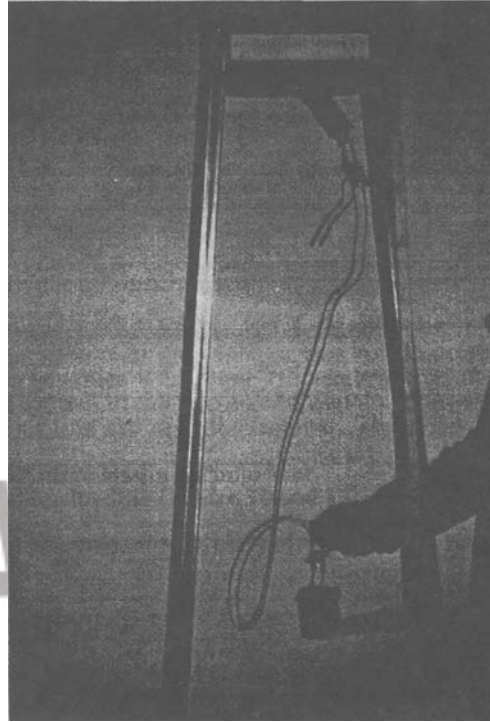

FIGURE 3  
PHOTOGRAPH OF TYPICAL WIRE REINFORCED TEST STRAP



**FIGURE 4**  
**PHOTOGRAPH OF DYNAMIC PULL-OFF TESTING**



**FIGURE 5**  
**PHOTOGRAPH OF DYNAMIC PULL-OFF TESTING**