

TESTING APPLICATION STANDARD (TAS) No. 108-95
TEST PROCEDURE FOR WIND TUNNEL TESTING OF
AIR PERMEABLE, RIGID, DISCONTINUOUS ROOF SYSTEMS

1. Scope:

1.1 This protocol covers procedures for determining the wind characteristics of an air permeable, rigid, discontinuous roof system. The test procedures herein provide the pressure distribution occurring, at various wind speeds, on the top and bottom surfaces of an instrumented component within a test specimen consisting of a wood deck; underlayment; and, an air permeable, rigid, discontinuous roof system. The calculations herein determine the coefficients of pressure (C_p) along the top and bottom surfaces of the instrumented component; the coefficient of lift (C_L); the coefficient of moment (C_{Ma}); and the aerodynamic multiplier (l) for the instrumented component.

NOTE: The coefficient of lift (C_L) need only be determined for 'S' shaped clay or concrete tile systems. In addition, the coefficient of moment (C_{Ma}) need not be determined for 'S' shaped clay or concrete tile systems. This is discussed further in Section 10.5.

1.2 The aerodynamic multiplier (l), determined under this protocol, is used to determine the attachment resistance (M_p) required for the particular type of system installed on a particular building in the high-velocity hurricane zone jurisdiction, in compliance with the attachment calculations set forth in RAS 127 and the wind load requirements set forth in Chapter 16 (High-Velocity Hurricane Zones) of the *Florida Building Code, Building*.

2. Referenced Documents:

2.1 *The Florida Building Code, Building*.

2.2 *Application Standards:*

TAS 101 Test Procedure for Static Uplift Testing of Mortar or Adhesive Set Tile Systems

TAS 102 Test Procedure for Static Uplift Testing of Mechanically Attached, Rigid Roof Systems

TAS 102(A) Test Procedure for Static Uplift Testing of Clipped, Rigid Roof Systems

TAS 116 Test Procedure for Air Permeability Testing of Rigid, Discontinuous Roof Systems

2.3 *Redland Technology - New Technology & Product Development Centre Fixing Studies for MRTI Normal Weight Tiles - SBCCI Submission*

2.4 *ASTM Standards:*

E 380 Excerpts from the Standard Practice for Use of the International System of Units (SI) (the Modernized Metric System)

2.5 *Roof Consultants Institute: Glossary of Terms*

3. Terminology & Units:

3.1 Definitions—For definitions of terms in this protocol, refer to Chapters 2 and Section 1513 of the *Florida Building Code, Building*; and/or *Fixing Studies for MRTI Normal Weight Tiles*; and/or the RCI Glossary of Terms. Definitions from the *Florida Building Code, Building* shall take precedence.

3.2 Units—For conversion of U.S. customary units to SI units, refer to ASTM E 380.

4. Significance and Use:

4.1 Use of this protocol is limited to systems which are air permeable, as determined in compliance with TAS 116 or deemed air permeable by the chief code compliance officer, in which the unsealed, overlap-

ping, rigid components have a length between 1.0 and 1.75 feet; an exposed width between 0.73 and 1.25 feet; and a thickness not greater than 1.3 in.

Note: The Chief Code Compliance Officer may waive the requirement for air permeability testing in compliance with TAS 116.

- 4.2 The procedures outlined in this protocol provide a means of determining the aerodynamic multiplier (I) for the air permeable, rigid, discontinuous roof system being tested. This aerodynamic multiplier (I) shall be listed in the system manufacturer's Product Approval for use in RAS 127, in combination with the rigid component's restoring moment due to gravity (M_g), determined in compliance with TAS 101 for mortar or adhesive set tile systems; TAS 102 for mechanically attached, rigid, discontinuous roof systems; TAS 102(A) for mechanically attached systems accompanied by a clip; and the wind load requirements set forth in Chapter 16 (High-Velocity Hurricane Zones) of the *Florida Building Code, Building*.

5. Apparatus:

5.1 The wind tunnel:

5.1.1 The wind tunnel shall be an open circuit wind tunnel capable of producing wind speeds up to 110 miles per hour. If the wind tunnel is unable to produce wind speeds of this magnitude, a wind constrictor of appropriate size shall be utilized to generate such wind speeds. The wind constrictor shall be fully sealed to around the edges to prevent air leakage. (See Figure 1, attached.)

5.1.2 A plenum chamber shall be located below area B of the test specimen, as noted in Figure 2, attached, to simulate an internal coefficient of pressure of + 0.25.

6. Precautions:

- 6.1 This protocol may involve hazardous materials, operations and equipment. This protocol does not purport to address all of the safety problems associated with its

use. It is the responsibility of the user to consult and establish appropriate safety and health practices and determine the applicability of regulatory limitations prior to use.

7. **Test Specimen**—the test specimen shall be constructed within the wind tunnel to avoid possible damage which may occur during transport.

7.1 Deck:

7.1.1 The wood deck sheathing shall be APA $32/16$ span rated sheathing of $15/32$ inch thickness, attached with 8d common nails at 6 inches o.c. at panel edges and 12 inches o.c. at intermediate supports. One transverse joint shall be included to simulate the potential for air leakage from below.

7.2 Underlayment

7.2.1 The underlayment shall be a standard 30/90 system with a 30 ASTM D 226, type II anchor sheet and an ASTM D 249 mineral surface roll roofing as the top ply.

7.2.2 The anchor sheet shall be mechanically attached to the wood sheathing, with 12 ga. roofing nails and $1\frac{5}{8}$ inch tin caps, in a 12 inch grid pattern staggered in two rows in the field and 6 inches o.c. at any laps. The mineral surface top ply shall be applied in a full mopping of ASTM D 312, type IV asphalt.

7.2.3 The underlayment edges shall be set in adhesive to provide an airtight, continuous seal around the perimeter of the test deck.

- 7.3 Area A, noted in Figure 2, shall be used to provide the boundary conditions for the air flow over Area B. The rigid components in Area A shall be rigidly attached to the substrate and shall extend not less than four courses. The rigid components in Area B shall be attached or bonded in compliance with the manufacturer's published installation instructions and shall extend not less than five courses. The width of the test specimen shall be not less than four laid components.

7.4 Mortar set tile systems:

||

7.4.1 Mortar mix shall have a roofing component product approval for use with the mortar set tile system and shall be in compliance with TAS 123.

minimum requirements set forth in Chapter 15 (High-Velocity Hurricane Zones) of the *Florida Building Code, Building*. The requirements of the *Florida Building Code, Building* shall take precedence.

||

7.4.2 Mortar shall be mixed using the mixing ratio specified in the mortar manufacturer's Product Approval.

7.6.2 Component attachment fasteners (i.e. nails, screws, tile straps, etc.) shall be those recommended by the system manufacturer's published installation instructions. Nails shall be not less than 0.109 inch in diameter and minimum screws shall be #8 diameter screw fasteners. Component attachment fasteners shall meet the corrosion requirements set forth in TAS 114, Appendix E.

7.4.3 Mortar flow shall be determined using a cone penetrometer test, in compliance with ASTM C 780 (Appendix A1), the results of which shall be $2\frac{1}{8} + \frac{1}{8}$ inch (55 + 3 mm) of penetration.

7.4.4 Mortar set tile shall be applied in a bed of mortar, the amount of which shall be a 10 inch trowel filled with mortar. The 10 inch trowel shall be placed at the same location beneath each tile on the test specimen with the exception of the instrumented tile noted in Section 7.9, herein.

7.6.3 Battens (if applicable):

7.6.3.1 Horizontal batten system

- Horizontal battens shall be of nominal 1 inch by 2 inch dimensional lumber and shall be spaced to provide a minimum 3 inch head lap, or to match the interlocking configuration of the component's profile.
- Apply one $\frac{1}{4}$ inch bead of approved sealant to the underside of horizontal battens and attach to the test deck at 6 inches o.c. using 12 ga. roofing nails, ensuring each nail penetrates the sealant bead.

7.4.5 Mortar set tile systems shall be allowed to cure at ambient conditions for a period of 24 hours prior to conducting the wind tunnel test.

7.5 Adhesive Set Tile Systems:

||

7.5.1 Adhesive shall have a roofing component product approval for use with the adhesive set tile system which is being tested and shall be applied in compliance with the provisions set forth in that approval.

7.6.3.2 Counter batten system

- Vertical battens shall be nominal 1 inch by 4 inch lumber and shall be spaced 24 inches over the intermediate supports (trusses).
- Apply one $\frac{1}{4}$ inch bead of approved sealant to the underside of vertical battens and attach to the test deck at 6 inches o.c. using 12 ga. roofing nails.
- Horizontal battens (counter battens) shall be as noted in Section 7.6.3.1, nailed to the 1

7.5.2 Adhesive set tile systems shall be allowed to cure for a period of 24 hours prior to conducting the wind tunnel test.

7.6 Mechanically Attached, Rigid, Discontinuous Roof Systems

||

7.6.1 Each component shall be installed in compliance with the system manufacturer's published installation instructions; the current Product Approval; and/or the

FLORENDA BUILDING CODE

2nd DRAFT

COPYRIGHT © ICC 2007

inch by 4 inch vertical battens using 12 ga. roofing nails of sufficient length to penetrate both battens.

7.7 Pressure Measurement, Top Surface

7.7.1 One component, located in the center of Area B, shall be instrumented with 20 pressure tappings (i.e. 20 holes drilled through the body and along the centerline of the component). The first 10 pressure tappings shall be equally spaced, toward the nose of the component, within the first $\frac{1}{3}$ of the component's length. The remaining 10 pressure tappings shall be equally spaced within the remaining $\frac{2}{3}$ of the component's length.

7.7.2 The tappings shall be sized to accept tubes which are solidly fixed through the holes at the bottom of the component. The opposite end of the tubes shall be connected to a suitable pressure measuring device which permits sampling of pressures in all 20 tubes. These pressure tappings allow for measurement of the static pressure distribution on the component's top surface.

7.8 Pressure measurement, bottom surface

7.8.1 The instrumented component, noted in Section 7.7, shall also be instrumented with seven (7) similar pressure tubes installed on the bottom surface, parallel along the length of the component. The first 4 pressure tubes shall be equally spaced, toward the nose of the component, within the first $\frac{1}{3}$ of the component's length. The remaining 3 pressure tubes shall be equally spaced within the remaining $\frac{2}{3}$ of the component's length.

7.8.2 These pressure tubes allow for measurement of the static pressure distribution on the component's bottom surface and shall be connected to a similar pressure measuring device.

7.9 For mortar or adhesive set tile systems, the instrumented tile shall be installed

with adhesive applied around the tile perimeter, as close as possible, but without interfering with the pressure tappings. The adhesive shall have similar flow properties to those noted in Section 7.4.3 and shall be applied to simulate the configuration of a typical mortar or adhesive patty.

7.10 All components along the side of the test specimen shall be sealed with adhesive tape to prevent air flow between the underside of the components and the slow moving layer of air on the side walls of the wind tunnel.

7.11 The test specimen shall be inspected by a professional engineer or registered roof Consultant, who shall certify, in the final report, that it was constructed in compliance with the provisions of this protocol.

8. Calibration:

8.1 Pressure tubes:

8.1.1 Each pressure tube from the tapped component shall be checked for leakage by applying a pressure to the tube and clamping it off. Leakage shall be identified by any pressure drop recorded by the pressure measuring device. Any pressure tube which exhibits leakage shall be repaired or replaced.

8.2 Pitot-static tube:

8.2.1 The pitot-static tube shall be cross-checked against a cup anemometer which gives an electrical output.

8.3 Manometer:

8.3.1 The manometer(s) shall be cross-checked against an electrical pressure transducer.

9. Test Procedure:

9.1 Construct the test specimen in testing position in the wind tunnel as noted in Section 7.

9.2 Position the pitot-static tube 4 inches above the test specimen at the junction be-

tween Area A and area B. Attach the pitot-static tube to pressure tube connections which allow measurement of the total pressure (p_{total}) and the free stream static pressure (p_{∞}). The velocity pressure (q) shall be determined by subtracting the free stream static pressure (p_{∞}) from the total pressure (p_{total}), as noted in Section 10.1.

- 9.3 Turn the wind generator on and set the pressure in the plenum chamber to reflect an internal pressure coefficient of +0.25.
- 9.4 Begin air flow over the test specimen at a wind speed of 70 mph, as measured at the pitot-static tube position, and hold until all pressure readings have stabilized. When pressure readings have stabilized, record the pressure readings on the top and bottom surfaces of the instrumented component.
- 9.5 Increase the wind speed to 80 mph and hold until all pressure readings have stabilized. When pressure readings have stabilized, record the pressure readings on the top and bottom surfaces of the instrumented component. Repeat this procedure in 10 mph increments until a wind speed of 110 mph is reached or until any portion of the test specimen experiences wind related damage.
- 9.6 Tabulate all of the top and bottom surface pressure readings for each wind speed at which pressure measurements were taken. Any system which experiences wind related damage prior to recording pressure measurements for the 90 mph windspeed shall be considered as a 're-test.'

- 10. Calculations**—The following calculations shall be performed for each of the wind speeds at which pressure measurements were taken.

10.1 Velocity Pressure (q)

10.1.1 Determine the velocity pressure (q) incurred over the test specimen by subtracting the free stream static pressure (p_{∞}) from the total pressure (p_{total}).

$$q = p_{total} - p_{\infty}$$

10.2 Coefficient of pressure (C_p)

10.2.1 Determine the coefficient of pressure for each of the top and bottom pressure tapings, (C_{pt} and C_{pb} respectively) using the following equations.

Surface:

Bottom Surface:

$$C_{pt} = \frac{P_t - P_{\infty}}{q} \quad C_{pb} = \frac{P_b - P_{\infty}}{q}$$

where,

C_{pt} = coefficient of pressure (top surface);

P_t = local pressure on component (top surface);

C_{pb} = coefficient of pressure (bottom surface);

P_b = local pressure on component (bottom surface);

P_{∞} = free stream static pressure; and,

q = velocity pressure

10.3 Coefficient of Lift (C_L)—the coefficient of lift (C_L) need only be determined for 'S' shaped clay or concrete tile systems. This is discussed further in Section 10.5.

10.3.1 Determine the coefficient of lift (C_L) for 'S' shaped clay or concrete tile systems using the coefficients of pressure (C_{pt} and C_{pb}) from Section 10.2 and the following equation.

$$C_L = \frac{\sum_0^7 C_{pb} \times \delta_{barea}}{l \times b} - \frac{\sum_0^{20} C_{pt} \times \delta_{tarea}}{l \times b}$$

where,

C_L = coefficient of lift;

C_{pb} = coefficient of pressure (bottom surface);

C_{pt} = coefficient of pressure (top surface);

δ_{barea} = elemental area at pressure tapping (bottom surface);

δ_{tarea} = elemental area at pressure tapping (top surface);

- l = tile length; and
 b = tile cover width.

10.3.2 If the variation of C_L values obtained over the wind speed range is no more than 5 percent, then the average value of C_L shall be evaluated and used to determine the aerodynamic multiplier (1), as noted in Section 10.5. If the variation in C_L values is greater than 5 percent, then the value obtained at the highest wind speed shall be utilized.

10.4 Coefficient of Moment (C_{Ma})—coefficient of moment (C_{Ma}) need not be determined for 'S' shaped clay or concrete tile systems.

10.4.1 Determine the coefficient of moment (C_{Ma}) using the coefficients of pressure (C_{Pt} and C_{Pb}) from 10.2 and the following equation.

$$C_{Ma} = \frac{\sum_0^7 C_{Pb} \times l'_b \times \delta_{barea}}{l^2 \times b} - \frac{\sum_0^{20} C_{Pt} \times l'_t \times \delta_{tarea}}{l^2 \times b}$$

where,

- C_{Ma} = coefficient of moment;
 C_{Pb} = coefficient of pressure (bottom surface);
 C_{Pt} = coefficient of pressure (top surface);
 δ_{barea} = elemental area at pressure tapping (bottom surface);
 δ_{tarea} = elemental area at pressure tapping (top surface);
 l'_b = moment arm acting at each pressure tapping (bottom surface);
 l'_t = moment arm acting at each pressure tapping (top surface);
 l = component length; and
 b = component cover width.

10.4.2 If the variation of C_{Ma} values obtained over the wind speed range is no more than 5 percent, then the

average value of C_{Ma} shall be evaluated and used to determine the aerodynamic multiplier (1), as noted in Section 10.6. If the variation in C_{Ma} values is greater than 5 percent, then the value obtained at the highest wind speed shall be utilized.

10.5 Aerodynamic multiplier (λ)—(for 'S' shaped clay or concrete tile systems)

10.5.1 Due to the shape and attachment point of 'S' shaped clay or concrete tile, the axis of rotation is different from that of other rigid, discontinuous roof systems and the aerodynamic multiplier (λ) for these tiles must be based on the aerodynamic moment about this axis. For this reason, the coefficient of moment (C'_{Ma}) for such tile systems needs to be an adjusted value (C'_{Ma}) to reflect rotation about this axis.

10.5.2 Determine the adjusted coefficient of moment (C'_{Ma}) using the coefficient of lift (C_L) from Section 10.3 and the following equation.

$$C'_{Ma} = C_L \times \frac{0.984}{l} \quad \text{where,}$$

- C'_{Ma} = adjusted coefficient of moment;
 C_L = coefficient of lift; and
 l = tile length.

10.5.3 Determine the aerodynamic multiplier (1) for 'S' shaped clay or concrete tile systems using the adjusted coefficient of moment (C'_{Ma}) from Section 10.5.2 and the following equation.

$$\lambda = C'_{Ma} \times b \times l^2 \quad \text{where,}$$

- λ = aerodynamic multiplier;
 C'_{Ma} = adjusted coefficient of moment;
 b = tile cover width; and
 l = tile length.

10.5.4 The aerodynamic multiplier (λ) shall be listed in the 'S' shaped clay or concrete tile system manufacturer's Product Approval for reference.

10.6 Aerodynamic Multiplier (λ) - (for all systems other than 'S' shaped clay or concrete tile systems)

10.6.1 Determine the aerodynamic multiplier (λ) for the system using the coefficient of moment (C_{Ma}), from Section 10.4 and the following equation.

$$\lambda = C'_{Ma} \times b \times l^2 \quad \text{where,}$$

λ = aerodynamic multiplier;
 C'_{Ma} = adjusted coefficient of moment;
 b = tile cover width; and
 l = tile length.

10.6.2 The aerodynamic multiplier (λ) shall be listed in the manufacturer's Product Approval for reference.

11. Report:

11.1 The final report shall include the following:

11.1.1 A description and sketch of the component, including the manufacturer and type of air permeable, rigid, discontinuous roof system.

11.1.2 A detailed report of the test specimen construction, including a photograph of the test specimen and certification by a professional engineer or registered roof consultant that the test specimen was constructed in compliance with the specifications of this Protocol.

11.1.3 Equipment calibration data or logs, certifying that the equipment was calibrated, in compliance with the provisions of this Protocol, prior to conducting the test.

11.1.4 Tabulated data on pressure measurements on the top and bottom surfaces of the instrumented component for each wind speed to which pressure measurements were taken.

11.1.5 Coefficient of pressure calculations for the top and bottom pressure tapping measurements (C_{pt} and C_{pb} , respectively) using the tabulated data noted in 11.1.4. Tabulate the results from these calculations.

11.1.6 Coefficient of lift (C_L) calculations, including confirmation that the variation in results is less than 5 percent. If the variation is less than 5 percent, include determination of an average C_L value. (These calculations are only required for 'S' shaped clay or concrete tile systems.)

11.1.7 Adjusted coefficient of moment (C'_{Ma}) calculations and results.

11.1.8 Coefficient of moment (C'_{Ma}) calculations, including confirmation that the variation in results is less than 5 percent. If the variation is less than 5 percent, include determination of the average of the C_{Ma} values. If the variation is greater than 5 percent, the C_{Ma} value at the maximum wind speed shall be utilized to determine the aerodynamic multiplier (λ). These calculations are not required for 'S' shaped clay or concrete tile systems.

11.1.9 Aerodynamic multiplier (λ) calculations from Section 10.5 for 'S' shaped clay or concrete tile systems or from Section 10.6 for all other systems.

11.1.10 Photographs of the following:

- the test specimen prior to the test;
- the test specimen after the test; and,
- the instrumented component (showing the pressure tappings and tubes)

on the top and bottom surfaces of the component)

11.1.11 The test report shall be signed and sealed by a professional engineer or a registered roof consultant.

NOTE: If the coefficients noted in Section 10 are determined with a computer program, provide confirmation that the equations in the program are in compliance with the provisions of this protocol. If this is the case, the report requirements noted in Sections 11.1.6 through 11.1.9 shall not be required.

FLORIDA BUILDING CODE

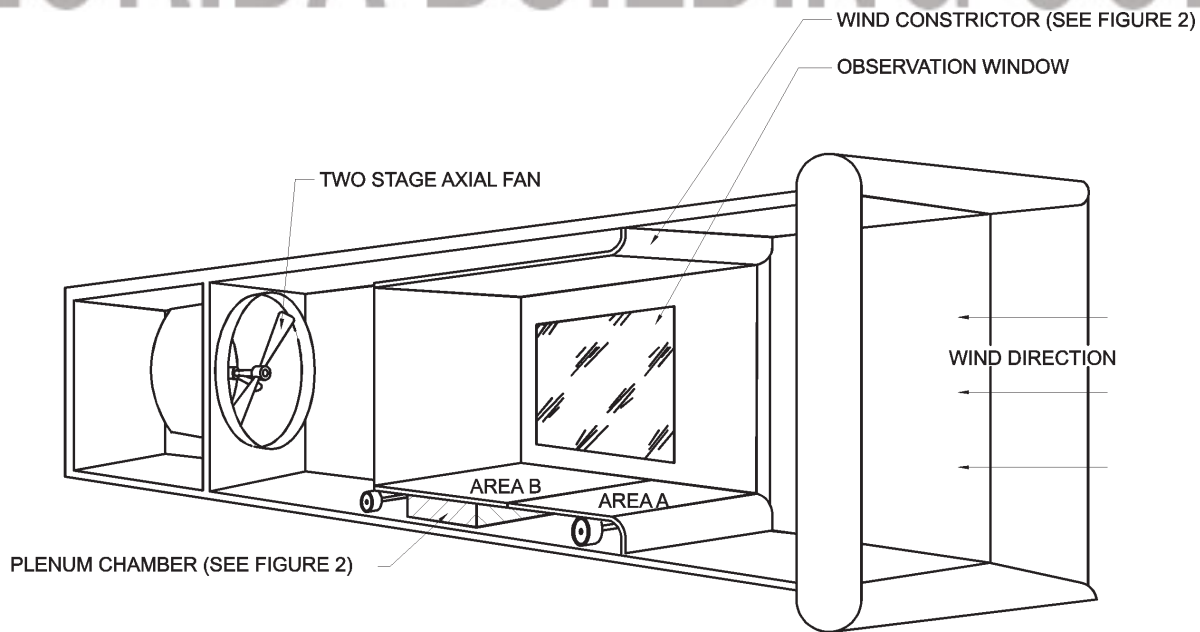

COPYRIGHT © ICC 2007

FIGURE 1
WIND TUNNEL TEST APPARATUS

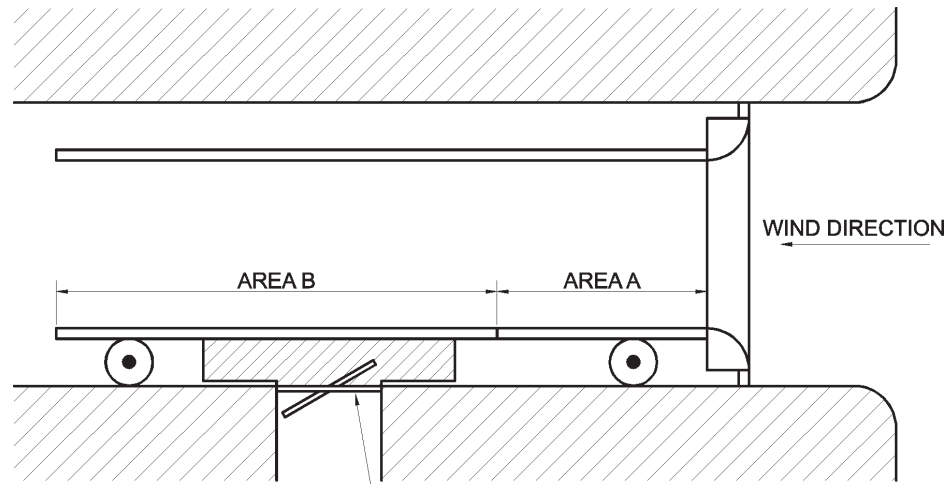

FLORIDA BUILDING CODE

FIGURE 2
WIND TUNNEL TEST APPARATUS (SIDE VIEW)

2nd DRAFT

COPYRIGHT® ICC 2007

FLORIDA BUILDING CODE

2nd DRAFT

COPYRIGHT® ICC 2007