

CHAPTER 29

WATER SUPPLY AND DISTRIBUTION

SECTION P2901 GENERAL

P2901.1 Potable water required. Dwelling units shall be supplied with potable water in the amounts and pressures specified in this chapter. In a building where both a potable and nonpotable water-distribution system are installed, each system shall be identified by color marking, metal tag or other appropriate method. Any nonpotable outlet that could inadvertently be used for drinking or domestic purposes shall be posted.

SECTION P2902 PROTECTION OF POTABLE WATER SUPPLY

P2902.1 General. A potable water supply system shall be designed and installed as to prevent contamination from nonpotable liquids, solids or gases being introduced into the potable water supply. Connections shall not be made to a potable water supply in a manner that could contaminate the water supply or provide a cross-connection between the supply and a source of contamination unless an approved backflow-prevention device is provided. Cross-connections between an individual water supply and a potable public water supply shall be prohibited.

P2902.2 Plumbing fixtures. The supply lines and fittings for every plumbing fixture shall be installed to prevent backflow. Plumbing fixture fittings shall provide backflow protection in accordance with ASME A112.18.1.

P2902.3 Backflow protection. A means of protection against backflow shall be provided in accordance with Sections P2902.3.1 through P2902.3.6. Backflow prevention applications shall conform to Table P2902.3, except as specifically stated in Sections P2902.4 through P2902.5.5.

P2902.3.1 Air gaps. Air gaps shall comply with ASME A112.1.2 and air gap fittings shall comply with ASME A112.1.3. The minimum air gap shall be measured vertically from the lowest end of a water supply outlet to the flood level rim of the fixture or receptor into which such potable water outlets discharge. The minimum required air gap shall be twice the diameter of the effective opening of the outlet, but in no case less than the values specified in Table P2902.3.1. An air gap is required at the discharge point of a relief valve or piping. Air gap devices shall be incorporated in dishwashing and clothes washing appliances.

P2902.3.2 Atmospheric-type vacuum breakers. Pipe-applied atmospheric-type vacuum breakers shall conform to ASSE 1001 or CSA B64.1.1. Hose-connection vacuum breakers shall conform to ASSE 1011, ASSE 1019, ASSE 1035, ASSE 1052, CSA B64.2, CSA B64.2.1, CSA B64.2.1.1, CSA B64.2.2 or CSA B64.7. These devices shall operate under normal atmospheric pressure when the critical level is installed at the required height.

P2902.3.3 Backflow preventer with intermediate atmospheric vent. Backflow preventers with intermediate atmospheric vents shall conform to ASSE 1012 or CSA CAN/CSA B64.3. These devices shall be permitted to be installed where subject to continuous pressure conditions. The relief opening shall discharge by air gap and shall be prevented from being submerged.

P2902.3.4 Pressure-type vacuum breakers. Pressure-type vacuum breakers shall conform to ASSE 1020 or CSA B64.1.2 and spillproof vacuum breakers shall comply with ASSE 1056. These devices are designed for installation under continuous pressure conditions when the critical level is installed at the required height. Pressure-type vacuum breakers shall not be installed in locations where spillage could cause damage to the structure.

P2902.3.5 Reduced pressure principle backflow preventers. Reduced pressure principle backflow preventers shall conform to ASSE 1013, AWWA C511, CSA B64.4 or CSA B64.4.1. Reduced pressure detector assembly backflow preventers shall conform to ASSE 1047. These devices shall be permitted to be installed where subject to continuous pressure conditions. The relief opening shall discharge by air gap and shall be prevented from being submerged.

P2902.3.6 Double check-valve assemblies. Double check-valve assemblies shall conform to ASSE 1015, CSA B64.5, CSA B64.5.1 or AWWA C510. Double-detector check-valve assemblies shall conform to ASSE 1048. These devices shall be capable of operating under continuous pressure conditions.

P2902.4 Protection of potable water outlets. Potable water openings and outlets shall be protected by an air gap, reduced pressure principle backflow preventer with atmospheric vent, atmospheric-type vacuum breaker, pressure-type vacuum breaker or hose connection backflow preventer.

P2902.4.1 Fill valves. Flush tanks shall be equipped with an antisiphon fill valve conforming to ASSE 1002 or CSA B125. The fill valve backflow preventer shall be located at least 1 inch (25 mm) above the full opening of the overflow pipe.

P2902.4.2 Deck-mounted and integral vacuum breakers. Approved deck-mounted vacuum breakers and faucets with integral atmospheric or spill-proof vacuum breakers shall be installed in accordance with the manufacturer's installation instructions and the requirements for labeling with the critical level not less than 1 inch (25 mm) above the flood level rim.

P2902.4.3 Hose connection. Sillcocks, hose bibbs, wall hydrants and other openings with a hose connection shall be protected by an atmospheric-type or pressure-type vacuum breaker or a permanently attached hose connection vacuum breaker.

**TABLE P2902.3
APPLICATION FOR BACKFLOW PREVENTERS**

DEVICE	DEGREE OF HAZARD ^a	APPLICATION ^b	APPLICABLE STANDARDS
Air gap	High or low hazard	Backsiphonage or backpressure	ASME A112.1.2
Air gap fittings for use with plumbing fixtures, appliances and appurtenances	High or low hazard	Backsiphonage or backpressure	ASME A112.1.3
Antisiphon-type fill valves for gravity water closet flush tanks	High hazard	Backsiphonage only	ASSE 1002 CSA CAN/CSA B125
Backflow preventer with intermediate atmospheric vents	Low hazard	Backpressure or backsiphonage Sizes 1/4" – 3/4"	ASSE 1012 CSA B64.3
Double check backflow prevention assembly and double check fire protection backflow prevention assembly	Low hazard	Backpressure or backsiphonage Sizes 3/8" – 16"	ASSE 1015, AWWA C510 CSA B64.5, CSA B64.5.1
Double check detector fire protection backflow prevention assemblies	Low hazard	Backpressure or backsiphonage (Fire sprinkler systems) Sizes 2" – 16"	ASSE 1048
Dual-check-valve-type backflow preventer	Low hazard	Backpressure or backsiphonage Sizes 1/4" – 1"	ASSE 1024, CSA B64.6
Hose connection backflow preventer	High or low hazard	Low head backpressure, rated working pressure backpressure or backsiphonage, Sizes 1/2" – 1"	ASSE 1052, CSA B64.2.1.1
Hose-connection vacuum breaker	High or low hazard	Low head backpressure or backsiphonage Sizes 1/2", 3/4", 1"	ASSE 1011, CSA B64.2, CSA B64.2.1
Laboratory faucet backflow preventer	High or low hazard	Low head backpressure and backsiphonage	ASSE 1035, CSA B64.7
Pipe-applied atmospheric-type vacuum breaker	High or low hazard	Backsiphonage only Sizes 1/4" – 4"	ASSE 1001 CSA B64.1.1
Pressure vacuum breaker assembly	High or low hazard	Backsiphonage only Sizes 1/2" – 2"	ASSE 1020, CSA B64.1.2
Reduced pressure detector fire protection backflow prevention assemblies	High or low hazard	Backsiphonage or backpressure (Fire sprinkler systems)	ASSE 1047
Reduced pressure principle backflow preventer and reduced pressure principle fire protection backflow preventer	High or low hazard	Backpressure or backsiphonage Sizes 3/8" – 16"	ASSE 1013, AWWA C511 CSA B64.4, CSA B64.4.1
Spillproof vacuum breaker	High or low hazard	Backsiphonage only Sizes 1/4" – 2"	ASSE 1056
Vacuum breaker wall hydrants, frost-resistant, automatic draining type	High or low hazard	Low head backpressure or backsiphonage Sizes 3/4" – 1"	ASSE 1019, CSA B64.2.2

For SI: 1 inch = 25.4 mm.

a. Low hazard—See Pollution (Section 202). High hazard—See Contamination (Section 202).

b. See Backpressure (Section 202). See Backpressure, Low Head (Section 202). See Backsiphonage (Section 202).

Exceptions:

1. This section shall not apply to water heater and boiler drain valves that are provided with hose connection threads and that are intended only for tank or vessel draining.
2. This section shall not apply to water supply valves intended for connection of clothes washing machines where backflow prevention is otherwise provided or is integral with the machine.

P2902.5 Protection of potable water connections. Connections to the potable water shall conform to Sections P2902.5.1 through P2902.5.5.

P2902.5.1 Connections to boilers. The potable supply to the boiler shall be equipped with a backflow preventer with an intermediate atmospheric vent complying with ASSE 1012 or CSA B64.3. Where conditioning chemicals are introduced into the system, the potable water connection shall be protected by an air gap or a reduced pressure principle backflow preventer complying with ASSE 1013, CSA B64.3 or AWWA C511.

**TABLE P2902.3.1
MINIMUM AIR GAPS**

FIXTURE	MINIMUM AIR GAP	
	Away from a wall ^a (inches)	Close to a wall (inches)
Effective openings greater than 1 inch	Two times the diameter of the effective opening	Three times the diameter of the effective opening
Lavatories and other fixtures with effective opening not greater than 1/2 inch in diameter	1	1.5
Over-rim bath fillers and other fixtures with effective openings not greater than 1 inch in diameter	2	3
Sink, laundry trays, gooseneck back faucets and other fixtures with effective openings not greater than 3/4 inch in diameter	1.5	2.5

For SI: 1 inch = 25.4 mm.

a. Applicable where walls or obstructions are spaced from the nearest inside edge of the spout opening a distance greater than three times the diameter of the effective opening for a single wall, or a distance greater than four times the diameter of the effective opening for two intersecting walls.

P2902.5.2 Heat exchangers. Heat exchangers using an essentially toxic transfer fluid shall be separated from the potable water by double-wall construction. An air gap open to the atmosphere shall be provided between the two walls. Heat exchangers utilizing an essentially nontoxic transfer fluid shall be permitted to be of single-wall construction.

P2902.5.3 Lawn irrigation systems. The potable water supply to lawn irrigation systems shall be protected against backflow by an atmospheric-type vacuum breaker, a pressure-type vacuum breaker or a reduced pressure principle backflow preventer. A valve shall not be installed downstream from an atmospheric vacuum breaker. Where chemicals are introduced into the system, the potable water supply shall be protected against backflow by a reduced pressure principle backflow preventer.

P2902.5.4 Connections to automatic fire sprinkler systems. The potable water supply to automatic fire sprinkler systems shall be protected against backflow by a double check-valve assembly or a reduced pressure principle backflow preventer.

Exception: Where systems are installed as a portion of the water distribution system in accordance with the requirements of this code and are not provided with a fire department connection, isolation of the water supply system shall not be required.

P2902.5.4.1 Additives or nonpotable source. Where systems contain chemical additives or antifreeze, or where systems are connected to a nonpotable secondary water supply, the potable water supply shall be protected against backflow by a reduced pressure principle

backflow preventer. Where chemical additives or antifreeze is added to only a portion of an automatic fire sprinkler or standpipe system, the reduced pressure principle backflow preventer shall be permitted to be located so as to isolate that portion of the system.

P2902.5.5 Solar systems. The potable water supply to a solar system shall be equipped with a backflow preventer with intermediate atmospheric vent complying with ASSE 1012 or a reduced pressure principle backflow preventer complying with ASSE 1013. Where chemicals are used, the potable water supply shall be protected by a reduced pressure principle backflow preventer.

Exception: Where all solar system piping is a part of the potable water distribution system, in accordance with the requirements of the *International Plumbing Code*, and all components of the piping system are listed for potable water use, cross-connection protection measure shall not be required.

P2902.6 Access. Backflow prevention devices shall be accessible for inspection and servicing.

**SECTION P2903
WATER-SUPPLY SYSTEM**

P2903.1 Water supply system design criteria. The water service and water distribution systems shall be designed and pipe sizes shall be selected such that under conditions of peak demand, the capacities at the point of outlet discharge shall not be less than shown in Table P2903.1.

**TABLE P2903.1
REQUIRED CAPACITIES AT
POINT OF OUTLET DISCHARGE**

FIXTURE AT POINT OF OUTLET	FLOW RATE (gpm)	FLOW PRESSURE (psi)
Bathtub	4	8
Bidet	2	4
Dishwasher	2.75	8
Laundry tub	4	8
Lavatory	2	8
Shower	3	8
Shower, temperature controlled	3	20
Sillcock, hose bibb	5	8
Sink	2.5	8
Water closet, flushometer tank	1.6	15
Water closet, tank, close coupled	3	8
Water closet, tank, one-piece	6	20

For SI: 1 gallon per minute = 3.785 L/m,
1 pound per square inch = 6.895 kPa.

P2903.2 Maximum flow and water consumption. The maximum water consumption flow rates and quantities for all plumbing fixtures and fixture fittings shall be in accordance with Table P2903.2.

**TABLE P2903.2
MAXIMUM FLOW RATES AND CONSUMPTION FOR
PLUMBING FIXTURES AND FIXTURE FITTINGS^a**

PLUMBING FIXTURE OR FIXTURE FITTING	PLUMBING FIXTURE OR FIXTURE FITTING
Lavatory faucet	2.2 gpm at 60 psi
Shower head ^a	2.5 gpm at 80 psi
Sink faucet	2.2 gpm at 60 psi
Water closet	1.6 gallons per flushing cycle

For SI: 1 gallon per minute = 3.785 L/m,
1 pound per square inch = 6.895 kPa.

- a. A handheld shower spray is also a shower head.
- b. Consumption tolerances shall be determined from referenced standards.

P2903.3 Minimum pressure. Minimum static pressure (as determined by the local water authority) at the building entrance for either public or private water service shall be 40 psi (276 kPa).

P2903.3.1 Maximum pressure. Maximum static pressure shall be 80 psi (551 kPa). When main pressure exceeds 80 psi (551 kPa), an approved pressure-reducing valve conforming to ASSE 1003 shall be installed on the domestic water branch main or riser at the connection to the water-service pipe.

P2903.4 Thermal expansion control. A means for controlling increased pressure caused by thermal expansion shall be installed where required in accordance with Sections P2903.4.1 and P2903.4.2.

P2903.4.1 Pressure-reducing valve. For water service system sizes up to and including 2 inches (51 mm), a device for controlling pressure shall be installed where, because of thermal expansion, the pressure on the downstream side of a pressure-reducing valve exceeds the pressure-reducing valve setting.

P2903.4.2 Backflow prevention device or check valve. Where a backflow prevention device, check valve or other device is installed on a water supply system using storage water heating equipment such that thermal expansion causes an increase in pressure, a device for controlling pressure shall be installed.

P2903.5 Water hammer. The flow velocity of the water distribution system shall be controlled to reduce the possibility of water hammer. A water-hammer arrestor shall be installed where quick-closing valves are used. Water-hammer arrestors shall be installed in accordance with manufacturers' specifications. Water-hammer arrestors shall conform to ASSE 1010.

P2903.6 Determining water-supply fixture units. Supply loads in the building water-distribution system shall be determined by total load on the pipe being sized, in terms of water-supply fixture units (w.s.f.u.), as shown in Table P2903.6, and gallon per minute (gpm) flow rates [see Table P2903.6(1)]. For fixtures not listed, choose a w.s.f.u. value of a fixture with similar flow characteristics.

P2903.7 Size of water-service mains, branch mains and risers. The minimum size water service pipe shall be 3/4 inch (19 mm). The size of water service mains, branch mains and risers shall be determined according to water supply demand [gpm (L/m)], available water pressure [psi (kPa)] and friction loss caused by the water meter and developed length of pipe [feet (m)], including equivalent length of fittings. The size of each water distribution system shall be determined according to the procedure outlined in this section or by other design methods conforming to acceptable engineering practice and approved by the administrative authority:

1. Obtain the minimum daily static service pressure [psi (kPa)] available (as determined by the local water authority) at the water meter or other source of supply at the installation location. Adjust this minimum daily static pressure [psi (kPa)] for the following conditions:
 - 1.1. Determine the difference in elevation between the source of supply and the highest water supply outlet. Where the highest water supply outlet is located above the source of supply, deduct 0.5 psi (3.4 kPa) for each foot (305 mm) of difference in elevation. Where the highest water supply outlet is located below the source of supply, add 0.5 psi (3.4 kPa) for each foot (305 mm) of difference in elevation.
 - 1.2. Where a water pressure reducing valve is installed in the water distribution system, the minimum daily static water pressure available is 80 percent of the minimum daily static water pressure at the source of supply or the set pressure downstream of the pressure reducing valve, whichever is smaller.

1.3. Deduct all pressure losses caused by special equipment such as a backflow preventer, water filter or water softener. Pressure loss data for each piece of equipment shall be obtained from the manufacturer of such devices.

1.4. Deduct the pressure in excess of 8 psi (55 kPa) caused by installation of special plumbing fixtures, such as temperature controlled showers and flushometer tank water closets.

Using the resulting minimum available pressure, find the corresponding pressure range in Table P2903.7.

2. The maximum developed length for water piping is the actual length of pipe between the source of supply and the most remote fixture, including either hot (through the water heater) or cold water branches multiplied by a factor of 1.2 to compensate for pressure loss through fittings.

Select the appropriate column in Table P2903.7 equal to or greater than the calculated maximum developed length.

3. To determine the size of water service pipe, meter and main distribution pipe to the building using the appropriate table, follow down the selected “maximum devel-

oped length” column to a fixture unit equal to, or greater than the total installation demand calculated by using the “combined” water supply fixture unit column of Table P2903.6. Read the water service pipe and meter sizes in the first left-hand column and the main distribution pipe to the building in the second left-hand column on the same row.

4. To determine the size of each water distribution pipe, start at the most remote outlet on each branch (either hot or cold branch) and, working back toward the main distribution pipe to the building, add up the water supply fixture unit demand passing through each segment of the distribution system using the related hot or cold column of Table P2903.6. Knowing demand, the size of each segment shall be read from the second left-hand column of the same table and a maximum developed length column selected in Steps 1 and 2, under the same or next smaller size meter row. In no case does the size of any branch or main need to be larger than the size of the main distribution pipe to the building established in Step 3.

P2903.8 Gridded and parallel water distribution system manifolds. Hot water and cold water manifolds installed with gridded or parallel-connected individual distribution lines to each fixture or fixture fittings shall be designed in accordance with Sections P2903.8.1 through P2903.8.6.

**TABLE P2903.6
WATER-SUPPLY FIXTURE-UNIT VALUES FOR VARIOUS PLUMBING FIXTURES AND FIXTURE GROUPS**

TYPE OF FIXTURES OR GROUP OF FIXTURES	WATER-SUPPLY FIXTURE-UNIT VALUE (w.s.f.u.)		
	Hot	Cold	Combined
Bathtub (with/without overhead shower head)	1.0	1.0	1.4
Clothes washer	1.0	1.0	1.4
Dishwasher	1.4	—	1.4
Full-bath group with bathtub (with/without shower head) or shower stall	1.5	2.7	3.6
Half-bath group (water closet and lavatory)	0.5	2.5	2.6
Hose bibb (sillcock) ^a	—	2.5	2.5
Kitchen group (dishwasher and sink with/without garbage grinder)	1.9	1.0	2.5
Kitchen sink	1.0	1.0	1.4
Laundry group (clothes washer standpipe and laundry tub)	1.8	1.8	2.5
Laundry tub	1.0	1.0	1.4
Lavatory	0.5	0.5	0.7
Shower stall	1.0	1.0	1.4
Water closet (tank type)	—	2.2	2.2

For SI: 1 gallon per minute = 3.785 L/m.

a. The fixture unit value 2.5 assumes a flow demand of 2.5 gpm, such as for an individual lawn sprinkler device. If a hose bibb/sill cock will be required to furnish a greater flow, the equivalent fixture-unit value may be obtained from this table or Table P2903.6(1).

P2903.8.1 Sizing of manifolds. Manifolds shall be sized in accordance with Table P2903.8.1. Total gallons per minute is the demand for all outlets.

P2903.8.2 Minimum size. Where the developed length of the distribution line is 60 feet (18 288 mm) or less, and the available pressure at the meter is a minimum of 40 pounds per square inch (276 kPa), the minimum size of individual distribution lines shall be $\frac{3}{8}$ inch (10 mm). Certain fixtures such as one-piece water closets and whirlpool bathtubs shall require a larger size where specified by the manufacturer. If a water

heater is fed from the end of a cold water manifold, the manifold shall be one size larger than the water heater feed.

P2903.8.3 Orientation. Manifolds shall be permitted to be installed in a horizontal or vertical position.

P2903.8.4 Support and protection. Plastic piping bundles shall be secured in accordance with the manufacturer's installation instructions and supported in accordance with Section P2605. Bundles that have a change in direction equal to or greater than 45 degrees (0.79 rad) shall be protected from chafing at the point of contact with framing members by sleeving or wrapping.

**TABLE P2903.6(1)
CONVERSIONS FROM WATER SUPPLY FIXTURE UNIT TO GALLON PER MINUTE FLOW RATES**

SUPPLY SYSTEMS PREDOMINANTLY FOR FLUSH TANKS			SUPPLY SYSTEM PREDOMINANTLY FOR FLUSH VALVES		
Load	Demand		Load	Demand	
(Water supply fixture units)	(Gallons per minute)	(Cubic feet per minute)	(Water supply fixture units)	(Gallons per minute)	(Cubic feet per minute)
1	3.0	0.04104	—	—	—
2	5.0	0.0684	—	—	—
3	6.5	0.86892	—	—	—
4	8.0	1.06944	—	—	—
5	9.4	1.256592	5	15.0	2.0052
6	10.7	1.430376	6	17.4	2.326032
7	11.8	1.577424	7	19.8	2.646364
8	12.8	1.711104	8	22.2	2.967696
9	13.7	1.831416	9	24.6	3.288528
10	14.6	1.951728	10	27.0	3.60936
11	15.4	2.058672	11	27.8	3.716304
12	16.0	2.13888	12	28.6	3.823248
13	16.5	2.20572	13	29.4	3.930192
14	17.0	2.27256	14	30.2	4.037136
15	17.5	2.3394	15	31.0	4.14408
16	18.0	2.90624	16	31.8	4.241024
17	18.4	2.459712	17	32.6	4.357968
18	18.8	2.513184	18	33.4	4.464912
19	19.2	2.566656	19	34.2	4.571856
20	19.6	2.620128	20	35.0	4.6788
25	21.5	2.87412	25	38.0	5.07984
30	23.3	3.114744	30	42.0	5.61356
35	24.9	3.328632	35	44.0	5.88192
40	26.3	3.515784	40	46.0	6.14928
45	27.7	3.702936	45	48.0	6.41664
50	29.1	3.890088	50	50.0	6.684

For SI: 1 gallon per minute = 3.785 L/m, 1 cubic foot per minute = 0.4719 L/s.

**TABLE P2903.7
MINIMUM SIZE OF WATER METERS, MAINS AND DISTRIBUTION PIPING
BASED ON WATER SUPPLY FIXTURE UNIT VALUES**

Pressure Range—30 to 39 psi

METER AND SERVICE PIPE (inches)	DISTRIBUTION PIPE (inches)	MAXIMUM DEVELOPMENT LENGTH (feet)									
		40	60	80	100	150	200	250	300	400	500
3/4	1/2 ^a	2.5	2	1.5	1.5	1	1	.5	.5	0	0
3/4	3/4	9.5	7.5	6	5.5	4	3.5	3	2.5	2	1.5
3/4	1	32	25	20	16.5	11	9	7.5	6.5	5.5	4.5
1	1	32	32	27	21	13.5	10	8	7	5.5	5
3/4	1 1/4	32	32	32	32	30	24	20	17	13	10.5
1	1 1/4	80	80	70	61	45	34	27	22	16	12
1 1/2	1 1/4	80	80	80	75	54	40	31	25	17.5	13
1	1 1/2	87	87	87	87	84	73	74	56	45	36
1 1/2	1 1/2	151	151	151	151	117	92	79	69	54	43

Pressure Range—40 to 49 psi

METER AND SERVICE PIPE (inches)	DISTRIBUTION PIPE (inches)	MAXIMUM DEVELOPMENT LENGTH (feet)									
		40	60	80	100	150	200	250	300	400	500
3/4	1/2 ^a	3	2.5	2	1.5	1.5	1	1	.5	.5	.5
3/4	3/4	9.5	9.5	8.5	7	5.5	4.5	3.5	3	2.5	2
3/4	1	32	32	32	26	18	13.5	10.5	9	7.5	6
1	1	32	32	32	32	21	15	11.5	9.5	7.5	6.5
3/4	1 1/4	32	32	32	32	32	32	32	27	21	16.5
1	1 1/4	80	80	80	80	65	52	42	35	26	20
1 1/2	1 1/4	80	80	80	80	75	59	48	39	28	21
1	1 1/2	87	87	87	87	87	87	87	78	65	55
1 1/2	1 1/2	151	151	151	151	151	130	109	93	75	63

Pressure Range—50 to 60 psi

METER AND SERVICE PIPE (inches)	DISTRIBUTION PIPE (inches)	MAXIMUM DEVELOPMENT LENGTH (feet)									
		40	60	80	100	150	200	250	300	400	500
3/4	1/2 ^a	3	3	2.5	2	1.5	1	1	1	.5	.5
3/4	3/4	9.5	9.5	9.5	8.5	6.5	5	4.5	4	3	2.5
3/4	1	32	32	32	32	25	18.5	14.5	12	9.5	8
1	1	32	32	32	32	30	22	16.5	13	10	8
3/4	1 1/4	32	32	32	32	32	32	32	32	29	24
1	1 1/4	80	80	80	80	80	68	57	48	35	28
1 1/2	1 1/4	80	80	80	80	80	75	63	53	39	29
1	1 1/2	87	87	87	87	87	87	87	87	82	70
1 1/2	1 1/2	151	151	151	151	151	151	139	120	94	79

(continued)

TABLE P2903.7—continued
MINIMUM SIZE OF WATER METERS, MAINS AND DISTRIBUTION PIPING
BASED ON WATER SUPPLY FIXTURE UNIT VALUES

Pressure Range—greater than 60 psi

METER AND SERVICE PIPE (inches)	DISTRIBUTION PIPE (inches)	MAXIMUM DEVELOPMENT LENGTH (feet)									
		40	60	80	100	150	200	250	300	400	500
3/4	1/2 ^a	3	3	3	2.5	2	1.5	1.5	1	1	.5
3/4	3/4	9.5	9.5	9.5	9.5	7.5	6	5	4.5	3.5	3
3/4	1	32	32	32	32	32	24	19.5	15.5	11.5	9.5
1	1	32	32	32	32	32	28	22	17	12	9.5
3/4	1 1/4	32	32	32	32	32	32	32	32	32	30
1	1 1/4	80	80	80	80	80	80	69	60	46	36
1 1/2	1 1/4	80	80	80	80	80	80	76	65	50	38
1	1 1/2	87	87	87	87	87	87	87	87	87	84
1 1/2	1 1/2	151	151	151	151	151	151	151	144	114	94

For SI: 1 inch = 25.4 mm, 1 foot = 304.8 mm, 1 pound per square inch = 6.895 kPa.

a. Minimum size for building supply is 3/4-inch pipe.

TABLE P2903.8.1
MANIFOLD SIZING

PLASTIC		METALLIC	
Nominal Size ID (inches)	Maximum ^a gpm	Nominal Size ID (inches)	Maximum ^a gpm
3/4	17	3/4	11
1	29	1	20
1 1/4	46	1 1/4	31
1 1/2	66	1 1/2	44

For SI: 1 inch = 25.4 mm, 1 gallon per minute = 3.785 L/m, 1 foot per second = 0.3048 m/s.

NOTE: See Table P2903.6 for w.s.f.u and Table 2903.6(1) for gallon-per-minute (gpm) flow rates.

a. Based on velocity limitation: plastic—12 fps; metal—8 fps.

P2903.8.5 Valving. Fixture valves, when installed, shall be located either at the fixture or at the manifold. If valves are installed at the manifold, they shall be labeled indicating the fixture served.

P2903.8.6 Hose bibb bleed. A readily accessible air bleed shall be installed in hose bibb supplies at the manifold or at the hose bibb exit point.

P2903.9 Valves. Valves shall be installed in accordance with Sections P2903.9.1 through P2903.9.3.

P2903.9.1 Service valve. Each dwelling unit shall be provided with an accessible main shutoff valve near the entrance of the water service. The valve shall be of a full-open type having nominal restriction to flow, with provision for drainage such as a bleed orifice or installation of a separate drain valve. Additionally, the water service shall be valved at the curb or property line in accordance with local requirements.

P2903.9.2 Water heater valve. A readily accessible full-open valve shall be installed in the cold-water supply pipe to each water heater at or near the water heater.

P2903.9.3 Fixture valves and access. Valves serving individual fixtures, appliances, risers and branches shall be provided with access. An individual shutoff valve shall be required on the fixture supply pipe to each plumbing fixture other than bathtubs and showers.

P2903.9.4 Valve requirements. Valves shall be of an approved type and compatible with the type of piping material installed in the system. Ball valves, gate valves, globe valves and plug valves intended to supply drinking water shall meet the requirements of NSF 61.

P2903.10 Hose bibb. Hose bibbs subject to freezing, including the “frost-proof” type, shall be equipped with an accessible stop-and-waste-type valve inside the building so that they can be controlled and/or drained during cold periods.

Exception: Frostproof hose bibbs installed such that the stem extends through the building insulation into an open heated or semiconditioned space need not be separately valved (see Figure P2903.10).

**SECTION P2904
MATERIALS, JOINTS AND CONNECTIONS**

P2904.1 Soil and groundwater. The installation of water service pipe, water distribution pipe, fittings, valves, appurtenances and gaskets shall be prohibited in soil and groundwater that is contaminated with solvents, fuels, organic compounds or other detrimental materials that cause permeation, corrosion, degradation or structural failure of the water service or water distribution piping material.

P2904.1.1 Investigation required. Where detrimental conditions are suspected by or brought to the attention of the building official, a chemical analysis of the soil and groundwater conditions shall be required to ascertain the acceptability of the water service material for the specific installation.

P2904.1.2 Detrimental condition. When a detrimental condition exists, approved alternate materials or alternate routing shall be required.

P2904.2 Lead content. Pipe and fittings used in the water-supply system shall have a maximum of 8 percent lead.

P2904.3 Polyethylene plastic piping installation. Polyethylene pipe shall be cut square using a cutter designed for plastic pipe. Except where joined by heat fusion, pipe ends shall be

chamfered to remove sharp edges. Pipe that has been kinked shall not be installed. For bends, the installed radius of pipe curvature shall be greater than 30 pipe diameters or the coil radius when bending with the coil. Coiled pipe shall not be bent beyond straight. Bends shall not be permitted within 10 pipe diameters of any fitting or valve. Joints between polyethylene plastic pipe and fittings shall comply with Sections P2904.3.1 and P2904.3.2.

P2904.3.1 Heat-fusion joints. Joint surfaces shall be clean and free from moisture. Joint surfaces shall be heated to melting temperature and joined. The joint shall be undisturbed until cool. Joints shall be made in accordance with ASTM D 2657.

P2904.3.2 Mechanical joints. Mechanical joints shall be installed in accordance with the manufacturer’s installation instructions.

P2904.4 Water service pipe. Water service pipe shall conform to NSF 61 and shall conform to one of the standards listed in Table P2904.4. Water service pipe or tubing, installed underground and outside of the structure, shall have a minimum working pressure rating of 160 pounds per square inch at 73°F (1103 kPa at 23°C). Where the water pressure exceeds 160 pounds per square inch (1103 kPa), piping material shall have a rated working pressure equal to or greater than the highest available pressure. Water service piping materials not third-party certified for water distribution shall terminate at or before the full open valve located at the entrance to the structure. Ductile iron water service piping shall be cement mortar lined in accordance with AWWA C104.

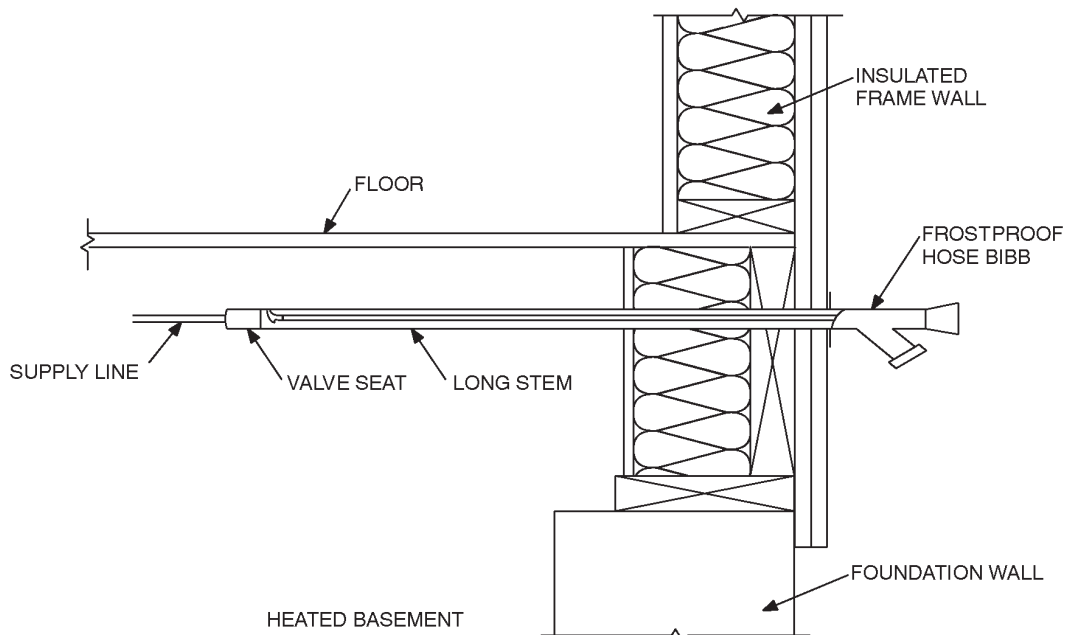

**FIGURE P2903.10
TYPICAL FROSTPROOF HOSE BIBB INSTALLATION NOT REQUIRING SEPARATE VALVE**

P2904.4.1 Dual check-valve-type backflow preventer. Where a dual check-valve backflow preventer is installed on the water supply system, it shall comply with ASSE 1024 or CSA B64.6.

P2904.4.2 Water service installation. Trenching, pipe installation and backfilling shall be in accordance with Section P2604. Water-service pipe is permitted to be located in the same trench with a building sewer provided such sewer is constructed of materials listed for underground use within a building in Section P3002.1. If the building sewer is not constructed of materials listed in Section P3002.1, the water-service pipe shall be separated from the building sewer by a minimum of 5 feet (1524 mm), measured horizontally, of undisturbed or compacted earth or placed on a solid ledge at least 12 inches (305 mm) above and to one side of the highest point in the sewer line.

Exception: The required separation distance shall not apply where a water service pipe crosses a sewer pipe, provided that the water service pipe is sleeved to at least 5 feet (1524 mm), horizontally from the sewer pipe centerline, on both sides of the crossing with pipe materials listed in Tables P2904.4, P3002.1(1), P3002.1(2) or P3002.2.

P2904.5 Water-distribution pipe. Water-distribution piping within dwelling units shall conform to NSF 61 and shall conform to one of the standards listed in Table P2904.5. All hot-water-distribution pipe and tubing shall have a minimum pressure rating of 100 psi at 180°F (689 kPa at 82°C).

P2904.5.1 Under concrete slabs. Inaccessible water distribution piping under slabs shall be copper water tube minimum Type L, brass, ductile iron pressure pipe, cross-linked polyethylene/aluminum/cross-linked polyethylene (PEX-AL-PEX) pressure pipe, polyethylene/aluminum/polyethylene (PE-AL-PE) pressure pipe, chlorinated polyvinyl chloride (CPVC), cross-linked polyethylene (PEX) plastic pipe or tubing or polypropylene (PP) pipe or tubing, all to be installed with approved fittings or bends. The minimum pressure rating for plastic pipe or tubing installed under slabs shall be 100 pounds per square inch at 180°F (689 kPa at 82°C).

P2904.6 Fittings. Pipe fittings shall be approved for installation with the piping material installed, and shall conform to the respective pipe standards listed in Table P2904.6. Pipe fittings used in the water supply system shall also conform to NSF 61.

**TABLE P2904.4
WATER SERVICE PIPE**

MATERIAL	STANDARD
Acrylonitrile butadiene styrene (ABS) plastic pipe	ASTM D 1527; ASTM D 2282
Asbestos-cement pipe	ASTM C 296
Brass pipe	ASTM B 43
Chlorinated polyvinyl chloride (CPVC) plastic pipe	ASTM D 2846; ASTM F 441; ASTM F 442; CSA B137.6
Copper or copper-alloy pipe	ASTM B 42; ASTM B 302
Copper or copper-alloy tubing (Type K, WK, L, WL, M or WM)	ASTM B 75; ASTM B 88; ASTM B 251; ASTM B 447
Cross-linked polyethylene/aluminum/cross-linked polyethylene (PEX-AL-PEX) pipe	ASTM F 1281; CSA CAN/CSA B137.10
Cross-linked polyethylene/aluminum/high-density polyethylene (PEX-AL-HDPE)	ASTM F 1986
Cross-linked polyethylene (PEX) plastic tubing	ASTM F 876; ASTM F 877; CSA B137.5
Ductile iron water pipe	AWWA C151; AWWA C115
Galvanized steel pipe	ASTM A 53
Polyethylene/aluminum/polyethylene (PE-AL-PE) pipe	ASTM F 1282; CSA CAN/CSA-B137.9M
Polyethylene (PE) plastic pipe	ASTM D 2104; ASTM D 2239; CSA-B137.1
Polyethylene (PE) plastic tubing	ASTM D 2737; CSA B137.1
Polypropylene (PP) plastic pipe or tubing	ASTM F 2389; CSA B137.11
Polyvinyl chloride (PVC) plastic pipe	ASTM D 1785; ASTM D 2241; ASTM D 2672; CSA B137.3
Stainless steel (Type 304/304L) pipe	ASTM A 312; ASTM A 778
Stainless steel (Type 316/316L) pipe	ASTM A 312; ASTM A 778

**TABLE P2904.5
WATER DISTRIBUTION PIPE**

MATERIAL	STANDARD
Brass pipe	ASTM B 43
Chlorinated polyvinyl chloride (CPVC) plastic pipe and tubing	ASTM D 2846; ASTM F 441; ASTM F 442; CSA B137.6
Copper or copper-alloy pipe	ASTM B 42; ASTM B 302
Copper or copper-alloy tubing (Type K, WK, L, WL, M or WM)	ASTM B 75; ASTM B 88; ASTM B 251; ASTM B 447
Cross-linked polyethylene (PEX) plastic tubing	ASTM F 877; CSA B137.5
Cross-linked polyethylene/aluminum/cross-linked polyethylene (PEX-AL-PEX) pipe	ASTM F 1281; CSACAN/CSA-B137.10
Cross-linked polyethylene/aluminum/high-density polyethylene (PEX-AL-HDPE)	ASTM F 1986
Galvanized steel pipe	ASTM A 53
Polyethylene/aluminum/polyethylene (PE-AL-PE) composite pipe	ASTM F 1282
Polypropylene (PP) plastic pipe or tubing	ASTM F 2389; CSA B137.11
Stainless steel (Type 304/304L) pipe	ASTM A 312; ASTM A 778
Stainless steel (Type 316/316L) pipe	ASTM A 312; ASTM A 778

**TABLE P2904.6
PIPE FITTINGS**

MATERIAL	STANDARD
Acrylonitrile butadiene styrene (ABS) plastic	ASTM D 2468
Brass	ASTM F1974
Cast-iron	ASME B16.4; ASME B16.12
Chlorinated polyvinyl chloride (CPVC) plastic	ASTM F 437; ASTM F 438; ASTM F 439; CSA B137.6
Copper or copper alloy	ASME B16.15; ASME B16.18; ASME B16.22; ASME B16.23; ASME B16.26; ASME B16.29
Cross-linked polyethylene/aluminum/high-density polyethylene (PEX-AL-HDPE)	ASTM F 1986
Fittings for cross-linked polyethylene (PEX) plastic tubing	ASTM F 877; ASTM F 1807; ASTM F 1960; ASTM F 2080; ASTM F 2159; CSA B137.5
Gray iron and ductile iron	AWWA C110; AWWA C153
Malleable iron	ASME B16.3
Polyethylene (PE) plastic	ASTM D 2609; CSA B137.1
Polypropylene (PP) plastic pipe or tubing	ASTM F 2389; CSA B137.11
Polyvinyl chloride (PVC) plastic	ASTM D 2464; ASTM D 2466; ASTM D 2467; CSA B137.2
Stainless steel (Type 304/304L) pipe	ASTM A 312; ASTM A 778
Stainless steel (Type 316/316L) pipe	ASTM A 312; ASTM A 778
Steel	ASME B16.9; ASME B16.11; ASME B16.28

P2904.7 Flexible water connectors. Flexible water connectors, exposed to continuous pressure, shall conform to ASME A112.18.6. Access shall be provided to all flexible water connectors.

P2904.8 Joint and connection tightness. Joints and connections in the plumbing system shall be gas tight and water tight for the intended use or required test pressure.

P2904.9 Plastic pipe joints. Joints in plastic piping shall be made with approved fittings by solvent cementing, heat fusion, corrosion-resistant metal clamps with insert fittings or compression connections. Flared joints for polyethylene pipe are permitted in accordance with Section P2904.3.

P2904.9.1 Solvent cementing. Solvent-cemented joints shall comply with Sections P2904.9.1.1 through P2904.9.1.3.

P2904.9.1.1 ABS plastic pipe. Solvent cement for ABS plastic pipe conforming to ASTM D 2235 shall be applied to all joint surfaces.

P2904.9.1.2 CPVC plastic pipe. Joint surfaces shall be clean and free from moisture and an approved primer shall be applied. Solvent cement for CPVC plastic pipe, orange in color and conforming to ASTM F 493, shall be applied to all joint surfaces. The parts shall be joined while the cement is wet and in accordance with ASTM D 2846 or ASTM F 493. Solvent-cement joints shall be permitted above or below ground.

Exception: A primer is not required where all of the following conditions apply:

1. The solvent cement used is third-party certified as conforming to ASTM F 493.
2. The solvent cement used is yellow in color.
3. The solvent cement is used only for joining 1/2-inch (13 mm) through 2-inch (51 mm) diameter CPVC pipe and fittings.
4. The CPVC pipe and fittings are manufactured in accordance with ASTM D 2846.

P2904.9.1.3 PVC plastic pipe. A purple primer that conforms to ASTM F 656 shall be applied to PVC solvent cemented joints. Solvent cement for PVC plastic pipe conforming to ASTM D 2564 shall be applied to all joint surfaces.

P2904.9.1.4 Cross-linked polyethylene plastic (PEX). Joints between cross-linked polyethylene plastic tubing or fittings shall comply with Section P2904.9.1.4.1 or Section P2904.9.1.4.2.

P2904.9.1.4.1 Flared joints. Flared pipe ends shall be made by a tool designed for that operation.

P2904.9.1.4.2 Mechanical joints. Mechanical joints shall be installed in accordance with the manufacturer's instructions. Fittings for cross-linked polyethylene (PEX) plastic tubing as described in ASTM F 877, ASTM F 1807, ASTM F 1960, and ASTM F 2080 shall be installed in accordance with the manufacturer's installation instructions.

P2904.10 Polypropylene (PP) plastic. Joints between PP plastic pipe and fittings shall comply with Section P2904.10.1 or P2904.10.2.

P2904.10.1 Heat-fusion joints. Heat fusion joints for polypropylene pipe and tubing joints shall be installed with socket-type heat-fused polypropylene fittings, butt-fusion polypropylene fittings or electrofusion polypropylene fittings. Joint surfaces shall be clean and free from moisture. The joint shall be undisturbed until cool. Joints shall be made in accordance with ASTM F 2389.

P2904.10.2 Mechanical and compression sleeve joints. Mechanical and compression sleeve joints shall be installed in accordance with the manufacturer's installation instructions.

P2904.11 Stainless steel. Joints between stainless steel pipe and fittings shall comply with Sections P2904.11.1 and P2904.11.2.

P2904.11.1 Mechanical joints. Mechanical joints shall be installed in accordance with the manufacturer's instructions.

P2904.11.2 Welded joints. Joint surfaces shall be cleaned. The joint shall be welded autogenously or with an approved filler metal in accordance with ASTM A 312.

P2904.12 Threaded pipe joints. Threaded joints shall conform to American National Taper Pipe Thread specifications. Pipe ends shall be deburred and chips removed. Pipe joint compound shall be used only on male threads.

P2904.13 Soldered joints. Soldered joints in tubing shall be made with fittings approved for water piping and shall conform to ASTM B 828. Surfaces to be soldered shall be cleaned bright. The joints shall be properly fluxed and made with approved solder. Solders and fluxes used in potable water-supply systems shall have a maximum of 0.2 percent lead. Fluxes shall conform to ASTM B 813.

P2904.14 Flared joints. Flared joints in water tubing shall be made with approved fittings. The tubing shall be reamed and then expanded with a flaring tool.

P2904.15 Underground joints. Joints in polybutylene (PB) plastic pipe or tubing underground or under a concrete floor slab shall be installed using heat fusion, in accordance with the manufacturer's installation instructions. Joints in copper pipe or tube installed in a concrete floor slab or under a concrete floor slab on grade shall be installed using wrought-copper fittings and brazed joints.

P2904.16 Above-ground joints. Joints within the building between copper pipe, polybutylene tubing or CPVC tubing, in any combination with compatible outside diameters, are permitted to be made with the use of approved push-in mechanical fittings of a pressure-lock design.

P2904.17 Joints between different materials. Joints between different piping materials shall be made in accordance with Sections P2904.17.1, P2904.17.2 and P2904.17.3 or with a mechanical joint of the compression or mechanical sealing type having an elastomeric seal conforming to ASTM D 1869 or ASTM F 477. Joints shall be installed in accordance with the manufacturer's instructions.

P2904.17.1 Copper or copper-alloy tubing to galvanized steel pipe. Joints between copper or copper-alloy tubing and galvanized steel pipe shall be made with a brass fitting or dielectric fitting. The copper tubing shall be joined to the fitting in an approved manner, and the fitting shall be screwed to the threaded pipe.

P2904.17.2 Plastic pipe or tubing to other piping material. Joints between different grades of plastic pipe or between plastic pipe and other piping material shall be made with an approved adapter fitting. Joints between plastic pipe and cast-iron hub pipe shall be made by a caulked joint or a mechanical compression joint.

P2904.17.3 Stainless steel. Joints between stainless steel and different piping materials shall be made with a mechanical joint of the compression or mechanical-sealing type or a dielectric fitting.

P2904.18 Press joints. Press-type mechanical joints in copper tubing shall be made in accordance with the manufacturer's instructions using approved tools which affix the copper fitting with integral O-ring to the tubing.

SECTION P2905 CHANGES IN DIRECTION

P2905.1 Bends. Changes in direction in copper tubing are permitted to be made with bends having a radius of not less than four diameters of the tube, providing such bends are made by use of forming equipment that does not deform or create loss in cross-sectional area of the tube.

SECTION P2906 SUPPORT

P2906.1 General. Pipe and tubing support shall conform to Section P2605.

SECTION P2907 DRINKING WATER TREATMENT UNITS

P2907.1 Design. Drinking water treatment units shall meet the requirements of NSF 42, NSF 44 or NSF 53.

P2907.2 Reverse osmosis drinking water treatment units. Point-of-use reverse osmosis drinking water treatment units, designed for residential use, shall meet the requirements of NSF 58. Waste or discharge from reverse osmosis drinking water treatment units shall enter the drainage system through an air gap or an air gap device that meets the requirements of NSF 58.

P2907.3 Connection tubing. The tubing to and from drinking water treatment units shall be of a size and material as recommended by the manufacturer. The tubing shall comply with NSF 14, NSF 42, NSF 44, NSF 53, NSF 58 or NSF 61.

