

CHAPTER 8

ROOF-CEILING CONSTRUCTION

SECTION R801 GENERAL

R801.1 Application. The provisions of this chapter shall control the design and construction of the roof-ceiling system for all buildings.

R801.2 Requirements. Roof and ceiling construction shall be capable of accommodating all loads imposed according to Section R301 and of transmitting the resulting loads to the supporting structural elements.

R801.3 Roof drainage. In areas where expansive or collapsible soils are known to exist, all dwellings shall have a controlled method of water disposal from roofs that will collect and discharge roof drainage to the ground surface at least 5 feet (1524 mm) from foundation walls or to an approved drainage system.

SECTION R802 WOOD ROOF FRAMING

R802.1 Identification. Load-bearing dimension lumber for rafters, trusses and ceiling joists shall be identified by a grade mark of a lumber grading or inspection agency that has been approved by an accreditation body that complies with DOC PS 20. In lieu of a grade mark, a certificate of inspection issued by a lumber grading or inspection agency meeting the requirements of this section shall be accepted.

R802.1.1 Blocking. Blocking shall be a minimum of utility grade lumber.

R802.1.2 End-jointed lumber. Approved end-jointed lumber identified by a grade mark conforming to Section R802.1 may be used interchangeably with solid-sawn members of the same species and grade.

R802.1.3 Fire-retardant-treated wood. Fire-retardant-treated wood (FRTW) is any wood product which, when impregnated with chemicals by a pressure process or other means during manufacture, shall have, when tested in accordance with ASTM E 84, a listed flame spread index of 25 or less and shows no evidence of significant progressive combustion when the test is continued for an additional 20-minute period. In addition, the flame front shall not progress more than 10.5 feet (3200 mm) beyond the center line of the burners at any time during the test.

R802.1.3.1 Labeling. Fire-retardant-treated lumber and wood structural panels shall be labeled. The label shall contain:

1. The identification mark of an approved agency in accordance with Section 1703.5 of the *International Building Code*.
2. Identification of the treating manufacturer.
3. The name of the fire-retardant treatment.

4. The species of wood treated.
5. Flame spread and smoke-developed rating.
6. Method of drying after treatment.
7. Conformance to appropriate standards in accordance with Sections R802.1.3.2 through R802.1.3.5.
8. For FRTW exposed to weather, or a damp or wet location, the words “No increase in the listed classification when subjected to the Standard Rain Test” (ASTM D 2898).

R802.1.3.2 Strength adjustments. Design values for untreated lumber and wood structural panels as specified in Section R802.1 shall be adjusted for fire-retardant-treated wood. Adjustments to design values shall be based upon an approved method of investigation which takes into consideration the effects of the anticipated temperature and humidity to which the fire-retardant-treated wood will be subjected, the type of treatment and redrying procedures.

R802.1.3.2.1 Wood structural panels. The effect of treatment and the method of redrying after treatment, and exposure to high temperatures and high humidities on the flexure properties of fire-retardant-treated softwood plywood shall be determined in accordance with ASTM D 5516. The test data developed by ASTM D 5516 shall be used to develop adjustment factors, maximum loads and spans, or both for untreated plywood design values in accordance with ASTM D 6305. Each manufacturer shall publish the allowable maximum loads and spans for service as floor and roof sheathing for their treatment.

R802.1.3.2.2 Lumber. For each species of wood treated, the effect of the treatment and the method of redrying after treatment and exposure to high temperatures and high humidities on the allowable design properties of fire-retardant-treated lumber shall be determined in accordance with ASTM D 5664. The test data developed by ASTM D 5664 shall be used to develop modification factors for use at or near room temperature and at elevated temperatures and humidity in accordance with ASTM D 6841. Each manufacturer shall publish the modification factors for service at temperatures of not less than 80°F (27°C) and for roof framing. The roof framing modification factors shall take into consideration the climatological location.

R802.1.3.3 Exposure to weather. Where fire-retardant-treated wood is exposed to weather or damp or wet locations, it shall be identified as “Exterior” to indicate there is no increase in the listed flame spread index as defined in Section R802.1.3 when subjected to ASTM D 2898.

R802.1.3.4 Interior applications. Interior fire-retardant-treated wood shall have a moisture content of not over 28 percent when tested in accordance with ASTM D 3201 procedures at 92 percent relative humidity. Interior fire-retardant-treated wood shall be tested in accordance with Section R802.1.3.2.1 or R802.1.3.2.2. Interior fire-retardant-treated wood designated as Type A shall be tested in accordance with the provisions of this section.

R802.1.3.5 Moisture content. Fire-retardant-treated wood shall be dried to a moisture content of 19 percent or less for lumber and 15 percent or less for wood structural panels before use. For wood kiln dried after treatment (KDAT) the kiln temperatures shall not exceed those used in kiln drying the lumber and plywood submitted for the tests described in Section R802.1.3.2.1 for plywood and R802.1.3.2.2 for lumber.

R802.1.4 Structural glued laminated timbers. Glued laminated timbers shall be manufactured and identified as required in AITC A190.1 and ASTM D 3737.

R802.1.5 Structural log members. Stress grading of structural log members of nonrectangular shape, as typically used in log buildings, shall be in accordance with ASTM D 3957. Such structural log members shall be identified by the grade mark of an approved lumber grading or inspection agency. In lieu of a grade mark on the material, a certificate of inspection as to species and grade issued by a lumber-grading or inspection agency meeting the requirements of this section shall be permitted to be accepted.

R802.2 Design and construction. The framing details required in Section R802 apply to roofs having a minimum slope of three units vertical in 12 units horizontal (25-percent slope) or greater. Roof-ceilings shall be designed and constructed in accordance with the provisions of this chapter and Figures R606.11(1), R606.11(2) and R606.11(3) or in accordance with AFPA/NDS. Components of roof-ceilings shall be fastened in accordance with Table R602.3(1).

R802.3 Framing details. Rafters shall be framed to ridge board or to each other with a gusset plate as a tie. Ridge board shall be at least 1-inch (25 mm) nominal thickness and not less in depth than the cut end of the rafter. At all valleys and hips there shall be a valley or hip rafter not less than 2-inch (51 mm) nominal thickness and not less in depth than the cut end of the rafter. Hip and valley rafters shall be supported at the ridge by a brace to a bearing partition or be designed to carry and distribute the specific load at that point. Where the roof pitch is less than three units vertical in 12 units horizontal (25-percent slope), structural members that support rafters and ceiling joists, such as ridge beams, hips and valleys, shall be designed as beams.

R802.3.1 Ceiling joist and rafter connections. Ceiling joists and rafters shall be nailed to each other in accordance with Table R802.5.1(9), and the rafter shall be nailed to the top wall plate in accordance with Table R602.3(1). Ceiling joists shall be continuous or securely joined in accordance with Table R802.5.1(9) where they meet over interior partitions and are nailed to adjacent rafters to provide a continu-

ous tie across the building when such joists are parallel to the rafters.

Where ceiling joists are not connected to the rafters at the top wall plate, joists connected higher in the attic shall be installed as rafter ties, or rafter ties shall be installed to provide a continuous tie. Where ceiling joists are not parallel to rafters, rafter ties shall be installed. Rafter ties shall be a minimum of 2-inch by 4-inch (51 mm by 102 mm) (nominal), installed in accordance with the connection requirements in Table R802.5.1(9), or connections of equivalent capacities shall be provided. Where ceiling joists or rafter ties are not provided, the ridge formed by these rafters shall be supported by a wall or girder designed in accordance with accepted engineering practice.

Collar ties or ridge straps to resist wind uplift shall be connected in the upper third of the attic space in accordance with Table R602.3(1).

Collar ties shall be a minimum of 1-inch by 4-inch (25 mm by 102 mm) (nominal), spaced not more than 4 feet (1219 mm) on center.

R802.3.2 Ceiling joists lapped. Ends of ceiling joists shall be lapped a minimum of 3 inches (76 mm) or butted over bearing partitions or beams and toenailed to the bearing member. When ceiling joists are used to provide resistance to rafter thrust, lapped joists shall be nailed together in accordance with Table R602.3(1) and butted joists shall be tied together in a manner to resist such thrust.

R802.4 Allowable ceiling joist spans. Spans for ceiling joists shall be in accordance with Tables R802.4(1) and R802.4(2). For other grades and species and for other loading conditions, refer to the AF&PA Span Tables for Joists and Rafters.

R802.5 Allowable rafter spans. Spans for rafters shall be in accordance with Tables R802.5.1(1) through R802.5.1(8). For other grades and species and for other loading conditions, refer to the AF&PA Span Tables for Joists and Rafters. The span of each rafter shall be measured along the horizontal projection of the rafter.

R802.5.1 Purlins. Installation of purlins to reduce the span of rafters is permitted as shown in Figure R802.5.1. Purlins shall be sized no less than the required size of the rafters that they support. Purlins shall be continuous and shall be supported by 2-inch by 4-inch (51 mm by 102 mm) braces installed to bearing walls at a slope not less than 45 degrees from the horizontal. The braces shall be spaced not more than 4 feet (1219 mm) on center and the unbraced length of braces shall not exceed 8 feet (2438 mm).

R802.6 Bearing. The ends of each rafter or ceiling joist shall have not less than 1½ inches (38 mm) of bearing on wood or metal and not less than 3 inches (76 mm) on masonry or concrete.

R802.6.1 Finished ceiling material. If the finished ceiling material is installed on the ceiling prior to the attachment of the ceiling to the walls, such as in construction at a factory, a compression strip of the same thickness as the finish ceiling material shall be installed directly above the top plate of bearing walls if the compressive strength of the finish ceiling material is less than the loads it will be required to with-

stand. The compression strip shall cover the entire length of such top plate and shall be at least one-half the width of the top plate. It shall be of material capable of transmitting the loads transferred through it.

R802.7 Cutting and notching. Structural roof members shall not be cut, bored or notched in excess of the limitations specified in this section.

R802.7.1 Sawn lumber. Notches in solid lumber joists, rafters and beams shall not exceed one-sixth of the depth of the member, shall not be longer than one-third of the depth of the member and shall not be located in the middle one-third of the span. Notches at the ends of the member shall not exceed one-fourth the depth of the member. The tension side of members 4 inches (102 mm) or greater in nominal thickness shall not be notched except at the ends of the members. The diameter of the holes bored or cut into members shall not exceed one-third the depth of the member. Holes shall not be closer than 2 inches (51 mm) to the top or bottom of the member, or to any other hole located in the member. Where the member is also notched, the hole shall not be closer than 2 inches (51 mm) to the notch.

Exception: Notches on cantilevered portions of rafters are permitted provided the dimension of the remaining portion of the rafter is not less than 4-inch nominal (102 mm) and the length of the cantilever does not exceed 24 inches (610 mm).

R802.7.2 Engineered wood products. Cuts, notches and holes bored in trusses, structural composite lumber, structural glue-laminated members or I-joists are prohibited except where permitted by the manufacturer's recommendations or where the effects of such alterations are specifically considered in the design of the member by a registered design professional.

R802.8 Lateral support. Rafters and ceiling joists having a depth-to-thickness ratio exceeding 5 to 1 based on nominal dimensions shall be provided with lateral support at points of bearing to prevent rotation.

R802.8.1 Bridging. Rafters and ceiling joists having a depth-to-thickness ratio exceeding 6 to 1 based on nominal dimensions shall be supported laterally by solid blocking, diagonal bridging (wood or metal) or a continuous 1-inch by 3-inch (25 mm by 76 mm) wood strip nailed across the rafters or ceiling joists at intervals not exceeding 8 feet (2438 mm).

R802.9 Framing of openings. Openings in roof and ceiling framing shall be framed with header and trimmer joists. When the header joist span does not exceed 4 feet (1219 mm), the header joist may be a single member the same size as the ceiling joist or rafter. Single trimmer joists may be used to carry a single header joist that is located within 3 feet (914 mm) of the trimmer joist bearing. When the header joist span exceeds 4 feet (1219 mm), the trimmer joists and the header joist shall be doubled and of sufficient cross section to support the ceiling joists or rafter framing into the header. Approved hangers shall be used for the header joist to trimmer joist connections when the header joist span exceeds 6 feet (1829 mm). Tail joists over 12 feet (3658 mm) long shall be supported at the header by

framing anchors or on ledger strips not less than 2 inches by 2 inches (51 mm by 51 mm).

R802.10 Wood trusses.

R802.10.1 Truss design drawings. Truss design drawings, prepared in conformance to Section R802.10.1, shall be provided to the building official and approved prior to installation. Truss design drawings shall include, at a minimum, the information specified below. Truss design drawing shall be provided with the shipment of trusses delivered to the jobsite.

1. Slope or depth, span and spacing.
2. Location of all joints.
3. Required bearing widths.
4. Design loads as applicable.
 - 4.1. Top chord live load (as determined from Section R301.6).
 - 4.2. Top chord dead load.
 - 4.3. Bottom chord live load.
 - 4.4. Bottom chord dead load.
 - 4.5. Concentrated loads and their points of application.
 - 4.6. Controlling wind and earthquake loads.
5. Adjustments to lumber and joint connector design values for conditions of use.
6. Each reaction force and direction.
7. Joint connector type and description (e.g., size, thickness or gage) and the dimensioned location of each joint connector except where symmetrically located relative to the joint interface.
8. Lumber size, species and grade for each member.
9. Connection requirements for:
 - 9.1. Truss to girder-truss.
 - 9.2. Truss ply to ply.
 - 9.3. Field splices.
10. Calculated deflection ratio and/or maximum description for live and total load.
11. Maximum axial compression forces in the truss members to enable the building designer to design the size, connections and anchorage of the permanent continuous lateral bracing. Forces shall be shown on the truss design drawing or on supplemental documents.
12. Required permanent truss member bracing location.

R802.10.2 Design. Wood trusses shall be designed in accordance with accepted engineering practice. The design and manufacture of metal-plate-connected wood trusses shall comply with ANSI/TPI 1. The truss design drawings shall be prepared by a registered professional where required by the statutes of the jurisdiction in which the project is to be constructed in accordance with Section R106.1.

TABLE R802.4(1)
CEILING JOIST SPANS FOR COMMON LUMBER SPECIES
(Uninhabitable attics without storage, live load = 10 psf, L/Δ = 240)

| CEILING JOIST SPACING (inches) | SPECIES AND GRADE | | DEAD LOAD = 5 psf | | | |
|--------------------------------|-------------------|----|-----------------------------|-----------------|-----------------|-----------------|
| | | | 2 x 4 | 2 x 6 | 2 x 8 | 2 x 10 |
| | | | Maximum ceiling joist spans | | | |
| | | | (feet - inches) | (feet - inches) | (feet - inches) | (feet - inches) |
| 12 | Douglas fir-larch | SS | 13-2 | 20-8 | Note a | Note a |
| | Douglas fir-larch | #1 | 12-8 | 19-11 | Note a | Note a |
| | Douglas fir-larch | #2 | 12-5 | 19-6 | 25-8 | Note a |
| | Douglas fir-larch | #3 | 10-10 | 15-10 | 20-1 | 24-6 |
| | Hem-fir | SS | 12-5 | 19-6 | 25-8 | Note a |
| | Hem-fir | #1 | 12-2 | 19-1 | 25-2 | Note a |
| | Hem-fir | #2 | 11-7 | 18-2 | 24-0 | Note a |
| | Hem-fir | #3 | 10-10 | 15-10 | 20-1 | 24-6 |
| | Southern pine | SS | 12-11 | 20-3 | Note a | Note a |
| | Southern pine | #1 | 12-8 | 19-11 | Note a | Note a |
| | Southern pine | #2 | 12-5 | 19-6 | 25-8 | Note a |
| | Southern pine | #3 | 11-6 | 17-0 | 21-8 | 25-7 |
| | Spruce-pine-fir | SS | 12-2 | 19-1 | 25-2 | Note a |
| | Spruce-pine-fir | #1 | 11-10 | 18-8 | 24-7 | Note a |
| | Spruce-pine-fir | #2 | 11-10 | 18-8 | 24-7 | Note a |
| | Spruce-pine-fir | #3 | 10-10 | 15-10 | 20-1 | 24-6 |
| 16 | Douglas fir-larch | SS | 11-11 | 18-9 | 24-8 | Note a |
| | Douglas fir-larch | #1 | 11-6 | 18-1 | 23-10 | Note a |
| | Douglas fir-larch | #2 | 11-3 | 17-8 | 23-0 | Note a |
| | Douglas fir-larch | #3 | 9-5 | 13-9 | 17-5 | 21-3 |
| | Hem-fir | SS | 11-3 | 17-8 | 23-4 | Note a |
| | Hem-fir | #1 | 11-0 | 17-4 | 22-10 | Note a |
| | Hem-fir | #2 | 10-6 | 16-6 | 21-9 | Note a |
| | Hem-fir | #3 | 9-5 | 13-9 | 17-5 | 21-3 |
| | Southern pine | SS | 11-9 | 18-5 | 24-3 | Note a |
| | Southern pine | #1 | 11-6 | 18-1 | 23-1 | Note a |
| | Southern pine | #2 | 11-3 | 17-8 | 23-4 | Note a |
| | Southern pine | #3 | 10-0 | 14-9 | 18-9 | 22-2 |
| | Spruce-pine-fir | SS | 11-0 | 17-4 | 22-10 | Note a |
| | Spruce-pine-fir | #1 | 10-9 | 16-11 | 22-4 | Note a |
| | Spruce-pine-fir | #2 | 10-9 | 16-11 | 22-4 | Note a |
| | Spruce-pine-fir | #3 | 9-5 | 13-9 | 17-5 | 21-3 |
| 19.2 | Douglas fir-larch | SS | 11-3 | 17-8 | 23-3 | Note a |
| | Douglas fir-larch | #1 | 10-10 | 17-0 | 22-5 | Note a |
| | Douglas fir-larch | #2 | 10-7 | 16-7 | 21-0 | 25-8 |
| | Douglas fir-larch | #3 | 8-7 | 12-6 | 15-10 | 19-5 |
| | Hem-fir | SS | 10-7 | 16-8 | 21-11 | Note a |
| | Hem-fir | #1 | 10-4 | 16-4 | 21-6 | Note a |
| | Hem-fir | #2 | 9-11 | 15-7 | 20-6 | 25-3 |
| | Hem-fir | #3 | 8-7 | 12-6 | 15-10 | 19-5 |
| | Southern -pine | SS | 11-0 | 17-4 | 22-10 | Note a |
| | Southern pine | #1 | 10-10 | 17-0 | 22-5 | Note a |
| | Southern pine | #2 | 10-7 | 16-8 | 21-11 | Note a |
| | Southern pine | #3 | 9-1 | 13-6 | 17-2 | 20-3 |
| | Spruce-pine-fir | SS | 10-4 | 16-4 | 21-6 | Note a |
| | Spruce-pine-fir | #1 | 10-2 | 15-11 | 21-0 | 25-8 |
| | Spruce-pine-fir | #2 | 10-2 | 15-11 | 21-0 | 25-8 |
| | Spruce-pine-fir | #3 | 8-7 | 12-6 | 15-10 | 19-5 |

(continued)

TABLE R802.4(1)—continued
CEILING JOIST SPANS FOR COMMON LUMBER SPECIES
(Uninhabitable attics without storage, live load = 10 psf, L/Δ = 240)

| CEILING JOIST SPACING (inches) | SPECIES AND GRADE | | DEAD LOAD = 5 psf | | | |
|--------------------------------|-------------------|-----------------|-----------------------------|-----------------|-----------------|--------|
| | | | 2 x 4 | 2 x 6 | 2 x 8 | 2 x 10 |
| | | | Maximum ceiling joist spans | | | |
| | | (feet - inches) | (feet - inches) | (feet - inches) | (feet - inches) | |
| 24 | Douglas fir-larch | SS | 10-5 | 16-4 | 21-7 | Note a |
| | Douglas fir-larch | #1 | 10-0 | 15-9 | 20-1 | 24-6 |
| | Douglas fir-larch | #2 | 9-10 | 14-10 | 18-9 | 22-11 |
| | Douglas fir-larch | #3 | 7-8 | 11-2 | 14-2 | 17-4 |
| | Hem-fir | SS | 9-10 | 15-6 | 20-5 | Note a |
| | Hem-fir | #1 | 9-8 | 15-2 | 19-7 | 23-11 |
| | Hem-fir | #2 | 9-2 | 14-5 | 18-6 | 22-7 |
| | Hem-fir | #3 | 7-8 | 11-2 | 14-2 | 17-4 |
| | Southern pine | SS | 10-3 | 16-1 | 21-2 | Note a |
| | Southern pine | #1 | 10-0 | 15-9 | 20-10 | Note a |
| | Southern pine | #2 | 9-10 | 15-6 | 20-1 | 23-11 |
| | Southern pine | #3 | 8-2 | 12-0 | 15-4 | 18-1 |
| | Spruce-pine-fir | SS | 9-8 | 15-2 | 19-11 | 25-5 |
| | Spruce-pine-fir | #1 | 9-5 | 14-9 | 18-9 | 22-11 |
| | Spruce-pine-fir | #2 | 9-5 | 14-9 | 18-9 | 22-11 |
| | Spruce-pine-fir | #3 | 7-8 | 11-2 | 14-2 | 17-4 |

Check sources for availability of lumber in lengths greater than 20 feet.

For SI: 1 inch = 25.4 mm, 1 foot = 304.8 mm, 1 pound per square foot = 0.0479kPa.

a. Span exceeds 26 feet in length.

ROOF-CEILING CONSTRUCTION

TABLE R802.4(2)
CEILING JOIST SPANS FOR COMMON LUMBER SPECIES
(Uninhabitable attics with limited storage, live load = 20 psf, L/Δ = 240)

| CEILING JOIST SPACING (inches) | SPECIES AND GRADE | | DEAD LOAD = 10 psf | | | |
|--------------------------------|-------------------|----|-----------------------------|-----------------|-----------------|-----------------|
| | | | 2 x 4 | 2 x 6 | 2 x 8 | 2 x 10 |
| | | | Maximum ceiling joist spans | | | |
| | | | (feet - inches) | (feet - inches) | (feet - inches) | (feet - inches) |
| 12 | Douglas fir-larch | SS | 10-5 | 16-4 | 21-7 | Note a |
| | Douglas fir-larch | #1 | 10-0 | 15-9 | 20-1 | 24-6 |
| | Douglas fir-larch | #2 | 9-10 | 14-10 | 18-9 | 22-11 |
| | Douglas fir-larch | #3 | 7-8 | 11-2 | 14-2 | 17-4 |
| | Hem-fir | SS | 9-10 | 15-6 | 20-5 | Note a |
| | Hem-fir | #1 | 9-8 | 15-2 | 19-7 | 23-11 |
| | Hem-fir | #2 | 9-2 | 14-5 | 18-6 | 22-7 |
| | Hem-fir | #3 | 7-8 | 11-2 | 14-2 | 17-4 |
| | Southern pine | SS | 10-3 | 16-1 | 21-2 | Note a |
| | Southern pine | #1 | 10-0 | 15-9 | 20-10 | Note a |
| | Southern pine | #2 | 9-10 | 15-6 | 20-1 | 23-11 |
| | Southern pine | #3 | 8-2 | 12-0 | 15-4 | 18-1 |
| | Spruce-pine-fir | SS | 9-8 | 15-2 | 19-11 | 25-5 |
| | Spruce-pine-fir | #1 | 9-5 | 14-9 | 18-9 | 22-11 |
| | Spruce-pine-fir | #2 | 9-5 | 14-9 | 18-9 | 22-11 |
| | Spruce-pine-fir | #3 | 7-8 | 11-2 | 14-2 | 17-4 |
| 16 | Douglas fir-larch | SS | 9-6 | 14-11 | 19-7 | 25-0 |
| | Douglas fir-larch | #1 | 9-1 | 13-9 | 17-5 | 21-3 |
| | Douglas fir-larch | #2 | 8-9 | 12-10 | 16-3 | 19-10 |
| | Douglas fir-larch | #3 | 6-8 | 9-8 | 12-4 | 15-0 |
| | Hem-fir | SS | 8-11 | 14-1 | 18-6 | 23-8 |
| | Hem-fir | #1 | 8-9 | 13-5 | 16-10 | 20-8 |
| | Hem-fir | #2 | 8-4 | 12-8 | 16-0 | 19-7 |
| | Hem-fir | #3 | 6-8 | 9-8 | 12-4 | 15-0 |
| | Southern pine | SS | 9-4 | 14-7 | 19-3 | 24-7 |
| | Southern pine | #1 | 9-1 | 14-4 | 18-11 | 23-1 |
| | Southern pine | #2 | 8-11 | 13-6 | 17-5 | 20-9 |
| | Southern pine | #3 | 7-1 | 10-5 | 13-3 | 15-8 |
| | Spruce-pine-fir | SS | 8-9 | 13-9 | 18-1 | 23-1 |
| | Spruce-pine-fir | #1 | 8-7 | 12-10 | 16-3 | 19-10 |
| | Spruce-pine-fir | #2 | 8-7 | 12-10 | 16-3 | 19-10 |
| | Spruce-pine-fir | #3 | 6-8 | 9-8 | 12-4 | 15-0 |
| 19.2 | Douglas fir-larch | SS | 8-11 | 14-0 | 18-5 | 23-4 |
| | Douglas fir-larch | #1 | 8-7 | 12-6 | 15-10 | 19-5 |
| | Douglas fir-larch | #2 | 8-0 | 11-9 | 14-10 | 18-2 |
| | Douglas fir-larch | #3 | 6-1 | 8-10 | 11-3 | 13-8 |
| | Hem-fir | SS | 8-5 | 13-3 | 17-5 | 22-3 |
| | Hem-fir | #1 | 8-3 | 12-3 | 15-6 | 18-11 |
| | Hem-fir | #2 | 7-10 | 11-7 | 14-8 | 17-10 |
| | Hem-fir | #3 | 6-1 | 8-10 | 11-3 | 13-8 |
| | Southern pine | SS | 8-9 | 13-9 | 18-1 | 23-1 |
| | Southern pine | #1 | 8-7 | 13-6 | 17-9 | 21-1 |
| | Southern pine | #2 | 8-5 | 12-3 | 15-10 | 18-11 |
| | Southern pine | #3 | 6-5 | 9-6 | 12-1 | 14-4 |
| | Spruce-pine-fir | SS | 8-3 | 12-11 | 17-1 | 21-8 |
| | Spruce-pine-fir | #1 | 8-0 | 11-9 | 14-10 | 18-2 |
| | Spruce-pine-fir | #2 | 8-0 | 11-9 | 14-10 | 18-2 |
| | Spruce-pine-fir | #3 | 6-1 | 8-10 | 11-3 | 13-8 |

(continued)

TABLE R802.4(2)—continued
CEILING JOIST SPANS FOR COMMON LUMBER SPECIES
 (Uninhabitable attics with limited storage, live load = 20 psf, L/Δ = 240)

| CEILING JOIST SPACING (inches) | SPECIES AND GRADE | | DEAD LOAD = 10 psf | | | |
|--------------------------------|-------------------|----|-----------------------------|-----------------|-----------------|-----------------|
| | | | 2 x 4 | 2 x 6 | 2 x 8 | 2 x 10 |
| | | | Maximum Ceiling Joist Spans | | | |
| | | | (feet - inches) | (feet - inches) | (feet - inches) | (feet - inches) |
| 24 | Douglas fir-larch | SS | 8-3 | 13-0 | 17-1 | 20-11 |
| | Douglas fir-larch | #1 | 7-8 | 11-2 | 14-2 | 17-4 |
| | Douglas fir-larch | #2 | 7-2 | 10-6 | 13-3 | 16-3 |
| | Douglas fir-larch | #3 | 5-5 | 7-11 | 10-0 | 12-3 |
| | Hem-fir | SS | 7-10 | 12-3 | 16-2 | 20-6 |
| | Hem-fir | #1 | 7-6 | 10-11 | 13-10 | 16-11 |
| | Hem-fir | #2 | 7-1 | 10-4 | 13-1 | 16-0 |
| | Hem-fir | #3 | 5-5 | 7-11 | 10-0 | 12-3 |
| | Southern pine | SS | 8-1 | 12-9 | 16-10 | 21-6 |
| | Southern pine | #1 | 8-0 | 12-6 | 15-10 | 18-10 |
| | Southern pine | #2 | 7-8 | 11-0 | 14-2 | 16-11 |
| | Southern pine | #3 | 5-9 | 8-6 | 10-10 | 12-10 |
| | Spruce-pine-fir | SS | 7-8 | 12-0 | 15-10 | 19-5 |
| | Spruce-pine-fir | #1 | 7-2 | 10-6 | 13-3 | 16-3 |
| | Spruce-pine-fir | #2 | 7-2 | 10-6 | 13-3 | 16-3 |
| | Spruce-pine-fir | #3 | 5-5 | 7-11 | 10-0 | 12-3 |

Check sources for availability of lumber in lengths greater than 20 feet.

For SI: 1 inch = 25.4 mm, 1 foot = 304.8 mm, 1 pound per square foot = 0.0479kPa.

a. Span exceeds 26 feet in length.

TABLE R802.5.1(1)
RAFTER SPANS FOR COMMON LUMBER SPECIES
 (Roof live load=20 psf, ceiling not attached to rafters, L/Δ = 180)

| RAFTER SPACING (inches) | SPECIES AND GRADE | DEAD LOAD = 10 psf | | | | | DEAD LOAD = 20 psf | | | | | |
|-------------------------|-------------------|-----------------------------------|-----------------|-----------------|-----------------|-----------------|--------------------|-----------------|-----------------|-----------------|-----------------|--------|
| | | 2 x 4 | 2 x 6 | 2 x 8 | 2 x 10 | 2 x 12 | 2 x 4 | 2 x 6 | 2 x 8 | 2 x 10 | 2 x 12 | |
| | | Maximum rafter spans ^a | | | | | | | | | | |
| | | (feet - inches) | (feet - inches) | (feet - inches) | (feet - inches) | (feet - inches) | (feet - inches) | (feet - inches) | (feet - inches) | (feet - inches) | (feet - inches) | |
| 12 | Douglas fir-larch | SS | 11-6 | 18-0 | 23-9 | Note b | Note b | 11-6 | 18-0 | 23-5 | Note b | Note b |
| | Douglas fir-larch | #1 | 11-1 | 17-4 | 22-5 | Note b | Note b | 10-6 | 15-4 | 19-5 | 23-9 | Note b |
| | Douglas fir-larch | #2 | 10-1 | 16-7 | 21-0 | 25-8 | Note b | 9-10 | 14-4 | 18-2 | 22-3 | 25-9 |
| | Douglas fir-larch | #3 | 8-7 | 12-6 | 15-10 | 19-5 | 22-6 | 7-5 | 10-10 | 13-9 | 16-9 | 19-6 |
| | Hem-fir | SS | 10-10 | 17-0 | 22-5 | Note b | Note b | 10-10 | 17-0 | 22-5 | Note b | Note b |
| | Hem-fir | #1 | 10-7 | 16-8 | 21-10 | Note b | Note b | 10-3 | 14-11 | 18-11 | 23-2 | Note b |
| | Hem-fir | #2 | 10-1 | 15-11 | 20-8 | 25-3 | Note b | 9-8 | 14-2 | 17-11 | 21-11 | 25-5 |
| | Hem-fir | #3 | 8-7 | 12-6 | 15-10 | 19-5 | 22-6 | 7-5 | 10-10 | 13-9 | 16-9 | 19-6 |
| | Southern pine | SS | 11-3 | 17-8 | 23-4 | Note b | Note b | 11-3 | 17-8 | 23-4 | Note b | Note b |
| | Southern pine | #1 | 11-1 | 17-4 | 22-11 | Note b | Note b | 11-1 | 17-3 | 21-9 | 25-10 | Note b |
| | Southern pine | #2 | 10-10 | 17-0 | 22-5 | Note b | Note b | 10-6 | 15-1 | 19-5 | 23-2 | Note b |
| | Southern pine | #3 | 9-1 | 13-6 | 17-2 | 20-3 | 24-1 | 7-11 | 11-8 | 14-10 | 17-6 | 20-11 |
| | Spruce-pine-fir | SS | 10-7 | 16-8 | 21-11 | Note b | Note b | 10-7 | 16-8 | 21-9 | Note b | Note b |
| | Spruce-pine-fir | #1 | 10-4 | 16-3 | 21-0 | 25-8 | Note b | 9-10 | 14-4 | 18-2 | 22-3 | 25-9 |
| Spruce-pine-fir | #2 | 10-4 | 16-3 | 21-0 | 25-8 | Note b | 9-10 | 14-4 | 18-2 | 22-3 | 25-9 | |
| Spruce-pine-fir | #3 | 8-7 | 12-6 | 15-10 | 19-5 | 22-6 | 7-5 | 10-10 | 13-9 | 16-9 | 19-6 | |
| 16 | Douglas fir-larch | SS | 10-5 | 16-4 | 21-7 | Note b | Note b | 10-5 | 16-0 | 20-3 | 24-9 | Note b |
| | Douglas fir-larch | #1 | 10-0 | 15-4 | 19-5 | 23-9 | Note b | 9-1 | 13-3 | 16-10 | 20-7 | 23-10 |
| | Douglas fir-larch | #2 | 9-10 | 14-4 | 18-2 | 22-3 | 25-9 | 8-6 | 12-5 | 15-9 | 19-3 | 22-4 |
| | Douglas fir-larch | #3 | 7-5 | 10-10 | 13-9 | 16-9 | 19-6 | 6-5 | 9-5 | 11-11 | 14-6 | 16-10 |
| | Hem-fir | SS | 9-10 | 15-6 | 20-5 | Note b | Note b | 9-10 | 15-6 | 19-11 | 24-4 | Note b |
| | Hem-fir | #1 | 9-8 | 14-11 | 18-11 | 23-2 | Note b | 8-10 | 12-11 | 16-5 | 20-0 | 23-3 |
| | Hem-fir | #2 | 9-2 | 14-2 | 17-11 | 21-11 | 25-5 | 8-5 | 12-3 | 15-6 | 18-11 | 22-0 |
| | Hem-fir | #3 | 7-5 | 10-10 | 13-9 | 16-9 | 19-6 | 6-5 | 9-5 | 11-11 | 14-6 | 16-10 |
| | Southern pine | SS | 10-3 | 16-1 | 21-2 | Note b | Note b | 10-3 | 16-1 | 21-2 | Note b | Note b |
| | Southern pine | #1 | 10-0 | 15-9 | 20-10 | 25-10 | Note b | 10-0 | 15-0 | 18-10 | 22-4 | Note b |
| | Southern pine | #2 | 9-10 | 15-1 | 19-5 | 23-2 | Note b | 9-1 | 13-0 | 16-10 | 20-1 | 23-7 |
| | Southern pine | #3 | 7-11 | 11-8 | 14-10 | 17-6 | 20-11 | 6-10 | 10-1 | 12-10 | 15-2 | 18-1 |
| | Spruce-pine-fir | SS | 9-8 | 15-2 | 19-11 | 25-5 | Note b | 9-8 | 14-10 | 18-10 | 23-0 | Note b |
| | Spruce-pine-fir | #1 | 9-5 | 14-4 | 18-2 | 22-3 | 25-9 | 8-6 | 12-5 | 15-9 | 19-3 | 22-4 |
| Spruce-pine-fir | #2 | 9-5 | 14-4 | 18-2 | 22-3 | 25-9 | 8-6 | 12-5 | 15-9 | 19-3 | 22-4 | |
| Spruce-pine-fir | #3 | 7-5 | 10-10 | 13-9 | 16-9 | 19-6 | 6-5 | 9-5 | 11-11 | 14-6 | 16-10 | |
| 19.2 | Douglas fir-larch | SS | 9-10 | 15-5 | 20-4 | 25-11 | Note b | 9-10 | 14-7 | 18-6 | 22-7 | Note b |
| | Douglas fir-larch | #1 | 9-5 | 14-0 | 17-9 | 21-8 | 25-2 | 8-4 | 12-2 | 15-4 | 18-9 | 21-9 |
| | Douglas fir-larch | #2 | 8-11 | 13-1 | 16-7 | 20-3 | 23-6 | 7-9 | 11-4 | 14-4 | 17-7 | 20-4 |
| | Douglas fir-larch | #3 | 6-9 | 9-11 | 12-7 | 15-4 | 17-9 | 5-10 | 8-7 | 10-10 | 13-3 | 15-5 |
| | Hem-fir | SS | 9-3 | 14-7 | 19-2 | 24-6 | Note b | 9-3 | 14-4 | 18-2 | 22-3 | 25-9 |
| | Hem-fir | #1 | 9-1 | 13-8 | 17-4 | 21-1 | 24-6 | 8-1 | 11-10 | 15-0 | 18-4 | 21-3 |
| | Hem-fir | #2 | 8-8 | 12-11 | 16-4 | 20-0 | 23-2 | 7-8 | 11-2 | 14-2 | 17-4 | 20-1 |
| | Hem-fir | #3 | 6-9 | 9-11 | 12-7 | 15-4 | 17-9 | 5-10 | 8-7 | 10-10 | 13-3 | 15-5 |
| | Southern pine | SS | 9-8 | 15-2 | 19-11 | 25-5 | Note b | 9-8 | 15-2 | 19-11 | 25-5 | Note b |
| | Southern pine | #1 | 9-5 | 14-10 | 19-7 | 23-7 | Note b | 9-3 | 13-8 | 17-2 | 20-5 | 24-4 |
| | Southern pine | #2 | 9-3 | 13-9 | 17-9 | 21-2 | 24-10 | 8-4 | 11-11 | 15-4 | 18-4 | 21-6 |
| | Southern pine | #3 | 7-3 | 10-8 | 13-7 | 16-0 | 19-1 | 6-3 | 9-3 | 11-9 | 13-10 | 16-6 |
| | Spruce-pine-fir | SS | 9-1 | 14-3 | 18-9 | 23-11 | Note b | 9-1 | 13-7 | 17-2 | 21-0 | 24-4 |
| | Spruce-pine-fir | #1 | 8-10 | 13-1 | 16-7 | 20-3 | 23-6 | 7-9 | 11-4 | 14-4 | 17-7 | 20-4 |
| Spruce-pine-fir | #2 | 8-10 | 13-1 | 16-7 | 20-3 | 23-6 | 7-9 | 11-4 | 14-4 | 17-7 | 20-4 | |
| Spruce-pine-fir | #3 | 6-9 | 9-11 | 12-7 | 15-4 | 17-9 | 5-10 | 8-7 | 10-10 | 13-3 | 15-5 | |

(continued)

TABLE R802.5.1(1)—continued
RAFTER SPANS FOR COMMON LUMBER SPECIES
 (Roof live load=20 psf, ceiling not attached to rafters, L/Δ = 180)

| RAFTER SPACING (inches) | SPECIES AND GRADE | | DEAD LOAD = 10 psf | | | | | DEAD LOAD = 20 psf | | | | |
|-------------------------|-------------------|----|-----------------------------------|-----------------|-----------------|-----------------|-----------------|--------------------|-----------------|-----------------|-----------------|-----------------|
| | | | 2 x 4 | 2 x 6 | 2 x 8 | 2 x 10 | 2 x 12 | 2 x 4 | 2 x 6 | 2 x 8 | 2 x 10 | 2 x 12 |
| | | | Maximum rafter spans ^a | | | | | | | | | |
| | | | (feet - inches) | (feet - inches) | (feet - inches) | (feet - inches) | (feet - inches) | (feet - inches) | (feet - inches) | (feet - inches) | (feet - inches) | (feet - inches) |
| 24 | Douglas fir-larch | SS | 9-1 | 14-4 | 18-10 | 23-4 | Note b | 8-11 | 13-1 | 16-7 | 20-3 | 23-5 |
| | Douglas fir-larch | #1 | 8-7 | 12-6 | 15-10 | 19-5 | 22-6 | 7-5 | 10-10 | 13-9 | 16-9 | 19-6 |
| | Douglas fir-larch | #2 | 8-0 | 11-9 | 14-10 | 18-2 | 21-0 | 6-11 | 10-2 | 12-10 | 15-8 | 18-3 |
| | Douglas fir-larch | #3 | 6-1 | 8-10 | 11-3 | 13-8 | 15-11 | 5-3 | 7-8 | 9-9 | 11-10 | 13-9 |
| | Hem-fir | SS | 8-7 | 13-6 | 17-10 | 22-9 | Note b | 8-7 | 12-10 | 16-3 | 19-10 | 23-0 |
| | Hem-fir | #1 | 8-4 | 12-3 | 15-6 | 18-11 | 21-11 | 7-3 | 10-7 | 13-5 | 16-4 | 19-0 |
| | Hem-fir | #2 | 7-11 | 11-7 | 14-8 | 17-10 | 20-9 | 6-10 | 10-0 | 12-8 | 15-6 | 17-11 |
| | Hem-fir | #3 | 6-1 | 8-10 | 11-3 | 13-8 | 15-11 | 5-3 | 7-8 | 9-9 | 11-10 | 13-9 |
| | Southern pine | SS | 8-11 | 14-1 | 18-6 | 23-8 | Note b | 8-11 | 14-1 | 18-6 | 22-11 | Note b |
| | Southern pine | #1 | 8-9 | 13-9 | 17-9 | 21-1 | 25-2 | 8-3 | 12-3 | 15-4 | 18-3 | 21-9 |
| | Southern pine | #2 | 8-7 | 12-3 | 15-10 | 18-11 | 22-2 | 7-5 | 10-8 | 13-9 | 16-5 | 19-3 |
| | Southern pine | #3 | 6-5 | 9-6 | 12-1 | 14-4 | 17-1 | 5-7 | 8-3 | 10-6 | 12-5 | 14-9 |
| | Spruce-pine-fir | SS | 8-5 | 13-3 | 17-5 | 21-8 | 25-2 | 8-4 | 12-2 | 15-4 | 18-9 | 21-9 |
| | Spruce-pine-fir | #1 | 8-0 | 11-9 | 14-10 | 18-2 | 21-0 | 6-11 | 10-2 | 12-10 | 15-8 | 18-3 |
| | Spruce-pine-fir | #2 | 8-0 | 11-9 | 14-10 | 18-2 | 21-0 | 6-11 | 10-2 | 12-10 | 15-8 | 18-3 |
| | Spruce-pine-fir | #3 | 6-1 | 8-10 | 11-3 | 13-8 | 15-11 | 5-3 | 7-8 | 9-9 | 11-10 | 13-9 |

Check sources for availability of lumber in lengths greater than 20 feet.

For SI: 1 inch = 25.4 mm, 1 foot = 304.8 mm, 1 pound per square foot = 0.0479kPa.

a. The tabulated rafter spans assume that ceiling joists are located at the bottom of the attic space or that some other method of resisting the outward push of the rafters on the bearing walls, such as rafter ties, is provided at that location. When ceiling joists or rafter ties are located higher in the attic space, the rafter spans shall be multiplied by the factors given below:

| H_C/H_R | Rafter Span Adjustment Factor |
|---------------|-------------------------------|
| 1/3 | 0.67 |
| 1/4 | 0.76 |
| 1/5 | 0.83 |
| 1/6 | 0.90 |
| 1/7.5 or less | 1.00 |

where:

H_C = Height of ceiling joists or rafter ties measured vertically above the top of the rafter support walls.

H_R = Height of roof ridge measured vertically above the top of the rafter support walls.

b. Span exceeds 26 feet in length.

TABLE R802.5.1(2)
RAFTER SPANS FOR COMMON LUMBER SPECIES
 (Roof live load=20 psf, ceiling attached to rafters, L/Δ = 240)

| RAFTER SPACING (inches) | SPECIES AND GRADE | DEAD LOAD = 10 psf | | | | | DEAD LOAD = 20 psf | | | | | |
|-------------------------|-------------------|-----------------------------------|-----------------|-----------------|-----------------|-----------------|--------------------|-----------------|-----------------|-----------------|-----------------|--------|
| | | 2 x 4 | 2 x 6 | 2 x 8 | 2 x 10 | 2 x 12 | 2 x 4 | 2 x 6 | 2 x 8 | 2 x 10 | 2 x 12 | |
| | | Maximum rafter spans ^a | | | | | | | | | | |
| | | (feet - inches) | (feet - inches) | (feet - inches) | (feet - inches) | (feet - inches) | (feet - inches) | (feet - inches) | (feet - inches) | (feet - inches) | (feet - inches) | |
| 12 | Douglas fir-larch | SS | 10-5 | 16-4 | 21-7 | Note b | Note b | 10-5 | 16-4 | 21-7 | Note b | Note b |
| | Douglas fir-larch | #1 | 10-0 | 15-9 | 20-10 | Note b | Note b | 10-0 | 15-4 | 19-5 | 23-9 | Note b |
| | Douglas fir-larch | #2 | 9-10 | 15-6 | 20-5 | 25-8 | Note b | 9-10 | 14-4 | 18-2 | 22-3 | 25-9 |
| | Douglas fir-larch | #3 | 8-7 | 12-6 | 15-10 | 19-5 | 22-6 | 7-5 | 10-10 | 13-9 | 16-9 | 19-6 |
| | Hem-fir | SS | 9-10 | 15-6 | 20-5 | Note b | Note b | 9-10 | 15-6 | 20-5 | Note b | Note b |
| | Hem-fir | #1 | 9-8 | 15-2 | 19-11 | 25-5 | Note b | 9-8 | 14-11 | 18-11 | 23-2 | Note b |
| | Hem-fir | #2 | 9-2 | 14-5 | 19-0 | 24-3 | Note b | 9-2 | 14-2 | 17-11 | 21-11 | 25-5 |
| | Hem-fir | #3 | 8-7 | 12-6 | 15-10 | 19-5 | 22-6 | 7-5 | 10-10 | 13-9 | 16-9 | 19-6 |
| | Southern pine | SS | 10-3 | 16-1 | 21-2 | Note b | Note b | 10-3 | 16-1 | 21-2 | Note b | Note b |
| | Southern pine | #1 | 10-0 | 15-9 | 20-10 | Note b | Note b | 10-0 | 15-9 | 20-10 | 25-10 | Note b |
| | Southern pine | #2 | 9-10 | 15-6 | 20-5 | Note b | Note b | 9-10 | 15-1 | 19-5 | 23-2 | Note b |
| | Southern pine | #3 | 9-1 | 13-6 | 17-2 | 20-3 | 24-1 | 7-11 | 11-8 | 14-10 | 17-6 | 20-11 |
| | Spruce-pine-fir | SS | 9-8 | 15-2 | 19-11 | 25-5 | Note b | 9-8 | 15-2 | 19-11 | 25-5 | Note b |
| | Spruce-pine-fir | #1 | 9-5 | 14-9 | 19-6 | 24-10 | Note b | 9-5 | 14-4 | 18-2 | 22-3 | 25-9 |
| | Spruce-pine-fir | #2 | 9-5 | 14-9 | 19-6 | 24-10 | Note b | 9-5 | 14-4 | 18-2 | 22-3 | 25-9 |
| Spruce-pine-fir | #3 | 8-7 | 12-6 | 15-10 | 19-5 | 22-6 | 7-5 | 10-10 | 13-9 | 16-9 | 19-6 | |
| 16 | Douglas fir-larch | SS | 9-6 | 14-11 | 19-7 | 25-0 | Note b | 9-6 | 14-11 | 19-7 | 24-9 | Note b |
| | Douglas fir-larch | #1 | 9-1 | 14-4 | 18-11 | 23-9 | Note b | 9-1 | 13-3 | 16-10 | 20-7 | 23-10 |
| | Douglas fir-larch | #2 | 8-11 | 14-1 | 18-2 | 22-3 | 25-9 | 8-6 | 12-5 | 15-9 | 19-3 | 22-4 |
| | Douglas fir-larch | #3 | 7-5 | 10-10 | 13-9 | 16-9 | 19-6 | 6-5 | 9-5 | 11-11 | 14-6 | 16-10 |
| | Hem-fir | SS | 8-11 | 14-1 | 18-6 | 23-8 | Note b | 8-11 | 14-1 | 18-6 | 23-8 | Note b |
| | Hem-fir | #1 | 8-9 | 13-9 | 18-1 | 23-1 | Note b | 8-9 | 12-11 | 16-5 | 20-0 | 23-3 |
| | Hem-fir | #2 | 8-4 | 13-1 | 17-3 | 21-11 | 25-5 | 8-4 | 12-3 | 15-6 | 18-11 | 22-0 |
| | Hem-fir | #3 | 7-5 | 10-10 | 13-9 | 16-9 | 19-6 | 6-5 | 9-5 | 11-11 | 14-6 | 16-10 |
| | Southern pine | SS | 9-4 | 14-7 | 19-3 | 24-7 | Note b | 9-4 | 14-7 | 19-3 | 24-7 | Note b |
| | Southern pine | #1 | 9-1 | 14-4 | 18-11 | 24-1 | Note b | 9-1 | 14-4 | 18-10 | 22-4 | Note b |
| | Southern pine | #2 | 8-11 | 14-1 | 18-6 | 23-2 | Note b | 8-11 | 13-0 | 16-10 | 20-1 | 23-7 |
| | Southern pine | #3 | 7-11 | 11-8 | 14-10 | 17-6 | 20-11 | 6-10 | 10-1 | 12-10 | 15-2 | 18-1 |
| | Spruce-pine-fir | SS | 8-9 | 13-9 | 18-1 | 23-1 | Note b | 8-9 | 13-9 | 18-1 | 23-0 | Note b |
| | Spruce-pine-fir | #1 | 8-7 | 13-5 | 17-9 | 22-3 | 25-9 | 8-6 | 12-5 | 15-9 | 19-3 | 22-4 |
| | Spruce-pine-fir | #2 | 8-7 | 13-5 | 17-9 | 22-3 | 25-9 | 8-6 | 12-5 | 15-9 | 19-3 | 22-4 |
| Spruce-pine-fir | #3 | 7-5 | 10-10 | 13-9 | 16-9 | 19-6 | 6-5 | 9-5 | 11-11 | 14-6 | 16-10 | |
| 19.2 | Douglas fir-larch | SS | 8-11 | 14-0 | 18-5 | 23-7 | Note b | 8-11 | 14-0 | 18-5 | 22-7 | Note b |
| | Douglas fir-larch | #1 | 8-7 | 13-6 | 17-9 | 21-8 | 25-2 | 8-4 | 12-2 | 15-4 | 18-9 | 21-9 |
| | Douglas fir-larch | #2 | 8-5 | 13-1 | 16-7 | 20-3 | 23-6 | 7-9 | 11-4 | 14-4 | 17-7 | 20-4 |
| | Douglas fir-larch | #3 | 6-9 | 9-11 | 12-7 | 15-4 | 17-9 | 5-10 | 8-7 | 10-10 | 13-3 | 15-5 |
| | Hem-fir | SS | 8-5 | 13-3 | 17-5 | 22-3 | Note b | 8-5 | 13-3 | 17-5 | 22-3 | 25-9 |
| | Hem-fir | #1 | 8-3 | 12-11 | 17-1 | 21-1 | 24-6 | 8-1 | 11-10 | 15-0 | 18-4 | 21-3 |
| | Hem-fir | #2 | 7-10 | 12-4 | 16-3 | 20-0 | 23-2 | 7-8 | 11-2 | 14-2 | 17-4 | 20-1 |
| | Hem-fir | #3 | 6-9 | 9-11 | 12-7 | 15-4 | 17-9 | 5-10 | 8-7 | 10-10 | 13-3 | 15-5 |
| | Southern pine | SS | 8-9 | 13-9 | 18-1 | 23-1 | Note b | 8-9 | 13-9 | 18-1 | 23-1 | Note b |
| | Southern pine | #1 | 8-7 | 13-6 | 17-9 | 22-8 | Note b | 8-7 | 13-6 | 17-2 | 20-5 | 24-4 |
| | Southern pine | #2 | 8-5 | 13-3 | 17-5 | 21-2 | 24-10 | 8-4 | 11-11 | 15-4 | 18-4 | 21-6 |
| | Southern pine | #3 | 7-3 | 10-8 | 13-7 | 16-0 | 19-1 | 6-3 | 9-3 | 11-9 | 13-10 | 16-6 |
| | Spruce-pine-fir | SS | 8-3 | 12-11 | 17-1 | 21-9 | Note b | 8-3 | 12-11 | 17-1 | 21-0 | 24-4 |
| | Spruce-pine-fir | #1 | 8-1 | 12-8 | 16-7 | 20-3 | 23-6 | 7-9 | 11-4 | 14-4 | 17-7 | 20-4 |
| | Spruce-pine-fir | #2 | 8-1 | 12-8 | 16-7 | 20-3 | 23-6 | 7-9 | 11-4 | 14-4 | 17-7 | 20-4 |
| Spruce-pine-fir | #3 | 6-9 | 9-11 | 12-7 | 15-4 | 17-9 | 5-10 | 8-7 | 10-10 | 13-3 | 15-5 | |

(continued)

TABLE R802.5.1(2)—continued
RAFTER SPANS FOR COMMON LUMBER SPECIES
 (Roof live load=20 psf, ceiling attached to rafters, L/Δ = 240)

| RAFTER SPACING (inches) | SPECIES AND GRADE | | DEAD LOAD = 10 psf | | | | | DEAD LOAD = 20 psf | | | | |
|-------------------------|-------------------|----|-----------------------------------|-----------------|-----------------|-----------------|-----------------|--------------------|-----------------|-----------------|-----------------|-----------------|
| | | | 2 x 4 | 2 x 6 | 2 x 8 | 2 x 10 | 2 x 12 | 2 x 4 | 2 x 6 | 2 x 8 | 2 x 10 | 2 x 12 |
| | | | Maximum rafter spans ^a | | | | | | | | | |
| | | | (feet - inches) | (feet - inches) | (feet - inches) | (feet - inches) | (feet - inches) | (feet - inches) | (feet - inches) | (feet - inches) | (feet - inches) | (feet - inches) |
| 24 | Douglas fir-larch | SS | 8-3 | 13-0 | 17-2 | 21-10 | Note b | 8-3 | 13-0 | 16-7 | 20-3 | 23-5 |
| | Douglas fir-larch | #1 | 8-0 | 12-6 | 15-10 | 19-5 | 22-6 | 7-5 | 10-10 | 13-9 | 16-9 | 19-6 |
| | Douglas fir-larch | #2 | 7-10 | 11-9 | 14-10 | 18-2 | 21-0 | 6-11 | 10-2 | 12-10 | 15-8 | 18-3 |
| | Douglas fir-larch | #3 | 6-1 | 8-10 | 11-3 | 13-8 | 15-11 | 5-3 | 7-8 | 9-9 | 11-10 | 13-9 |
| | Hem-fir | SS | 7-10 | 12-3 | 16-2 | 20-8 | 25-1 | 7-10 | 12-3 | 16-2 | 19-10 | 23-0 |
| | Hem-fir | #1 | 7-8 | 12-0 | 15-6 | 18-11 | 21-11 | 7-3 | 10-7 | 13-5 | 16-4 | 19-0 |
| | Hem-fir | #2 | 7-3 | 11-5 | 14-8 | 17-10 | 20-9 | 6-10 | 10-0 | 12-8 | 15-6 | 17-11 |
| | Hem-fir | #3 | 6-1 | 8-10 | 11-3 | 13-8 | 15-11 | 5-3 | 7-8 | 9-9 | 11-10 | 13-9 |
| | Southern pine | SS | 8-1 | 12-9 | 16-10 | 21-6 | Note b | 8-1 | 12-9 | 16-10 | 21-6 | Note b |
| | Southern pine | #1 | 8-0 | 12-6 | 16-6 | 21-1 | 25-2 | 8-0 | 12-3 | 15-4 | 18-3 | 21-9 |
| | Southern pine | #2 | 7-10 | 12-3 | 15-10 | 18-11 | 22-2 | 7-5 | 10-8 | 13-9 | 16-5 | 19-3 |
| | Southern pine | #3 | 6-5 | 9-6 | 12-1 | 14-4 | 17-1 | 5-7 | 8-3 | 10-6 | 12-5 | 14-9 |
| | Spruce-pine-fir | SS | 7-8 | 12-0 | 15-10 | 20-2 | 24-7 | 7-8 | 12-0 | 15-4 | 18-9 | 21-9 |
| | Spruce-pine-fir | #1 | 7-6 | 11-9 | 14-10 | 18-2 | 21-0 | 6-11 | 10-2 | 12-10 | 15-8 | 18-3 |
| | Spruce-pine-fir | #2 | 7-6 | 11-9 | 14-10 | 18-2 | 21-0 | 6-11 | 10-2 | 12-10 | 15-8 | 18-3 |
| | Spruce-pine-fir | #3 | 6-1 | 8-10 | 11-3 | 13-8 | 15-11 | 5-3 | 7-8 | 9-9 | 11-10 | 13-9 |

Check sources for availability of lumber in lengths greater than 20 feet.

For SI: 1 inch = 25.4 mm, 1 foot = 304.8 mm, 1 pound per square foot = 0.0479kPa.

- a. The tabulated rafter spans assume that ceiling joists are located at the bottom of the attic space or that some other method of resisting the outward push of the rafters on the bearing walls, such as rafter ties, is provided at that location. When ceiling joists or rafter ties are located higher in the attic space, the rafter spans shall be multiplied by the factors given below:

| H_C/H_R | Rafter Span Adjustment Factor |
|---------------|-------------------------------|
| 1/3 | 0.67 |
| 1/4 | 0.76 |
| 1/5 | 0.83 |
| 1/6 | 0.90 |
| 1/7.5 or less | 1.00 |

where:

H_C = Height of ceiling joists or rafter ties measured vertically above the top of the rafter support walls.

H_R = Height of roof ridge measured vertically above the top of the rafter support walls.

- b. Span exceeds 26 feet in length.

TABLE R802.5.1(3)
RAFTER SPANS FOR COMMON LUMBER SPECIES
 (Ground snow load=30 psf, ceiling not attached to rafters, L/Δ = 180)

| RAFTER SPACING (inches) | SPECIES AND GRADE | DEAD LOAD = 10 psf | | | | | DEAD LOAD = 20 psf | | | | | |
|-------------------------|-------------------|-----------------------------------|-----------------|-----------------|-----------------|-----------------|--------------------|-----------------|-----------------|-----------------|-----------------|-----------------|
| | | 2 x 4 | 2 x 6 | 2 x 8 | 2 x 10 | 2 x 12 | 2 x 4 | 2 x 6 | 2 x 8 | 2 x 10 | 2 x 12 | |
| | | Maximum rafter spans ^a | | | | | | | | | | |
| | | (feet - inches) | (feet - inches) | (feet - inches) | (feet - inches) | (feet - inches) | (feet - inches) | (feet - inches) | (feet - inches) | (feet - inches) | (feet - inches) | (feet - inches) |
| 12 | Douglas fir-larch | SS | 10-0 | 15-9 | 20-9 | Note b | Note b | 10-0 | 15-9 | 20-1 | 24-6 | Note b |
| | Douglas fir-larch | #1 | 9-8 | 14-9 | 18-8 | 22-9 | Note b | 9-0 | 13-2 | 16-8 | 20-4 | 23-7 |
| | Douglas fir-larch | #2 | 9-5 | 13-9 | 17-5 | 21-4 | 24-8 | 8-5 | 12-4 | 15-7 | 19-1 | 22-1 |
| | Douglas fir-larch | #3 | 7-1 | 10-5 | 13-2 | 16-1 | 18-8 | 6-4 | 9-4 | 11-9 | 14-5 | 16-8 |
| | Hem-fir | SS | 9-6 | 14-10 | 19-7 | 25-0 | Note b | 9-6 | 14-10 | 19-7 | 24-1 | Note b |
| | Hem-fir | #1 | 9-3 | 14-4 | 18-2 | 22-2 | 25-9 | 8-9 | 12-10 | 16-3 | 19-10 | 23-0 |
| | Hem-fir | #2 | 8-10 | 13-7 | 17-2 | 21-0 | 24-4 | 8-4 | 12-2 | 15-4 | 18-9 | 21-9 |
| | Hem-fir | #3 | 7-1 | 10-5 | 13-2 | 16-1 | 18-8 | 6-4 | 9-4 | 11-9 | 14-5 | 16-8 |
| | Southern pine | SS | 9-10 | 15-6 | 20-5 | Note b | Note b | 9-10 | 15-6 | 20-5 | Note b | Note b |
| | Southern pine | #1 | 9-8 | 15-2 | 20-0 | 24-9 | Note b | 9-8 | 14-10 | 18-8 | 22-2 | Note b |
| | Southern pine | #2 | 9-6 | 14-5 | 18-8 | 22-3 | Note b | 9-0 | 12-11 | 16-8 | 19-11 | 23-4 |
| | Southern pine | #3 | 7-7 | 11-2 | 14-3 | 16-10 | 20-0 | 6-9 | 10-0 | 12-9 | 15-1 | 17-11 |
| | Spruce-pine-fir | SS | 9-3 | 14-7 | 19-2 | 24-6 | Note b | 9-3 | 14-7 | 18-8 | 22-9 | Note b |
| | Spruce-pine-fir | #1 | 9-1 | 13-9 | 17-5 | 21-4 | 24-8 | 8-5 | 12-4 | 15-7 | 19-1 | 22-1 |
| | Spruce-pine-fir | #2 | 9-1 | 13-9 | 17-5 | 21-4 | 24-8 | 8-5 | 12-4 | 15-7 | 19-1 | 22-1 |
| Spruce-pine-fir | #3 | 7-1 | 10-5 | 13-2 | 16-1 | 18-8 | 6-4 | 9-4 | 11-9 | 14-5 | 16-8 | |
| 16 | Douglas fir-larch | SS | 9-1 | 14-4 | 18-10 | 23-9 | Note b | 9-1 | 13-9 | 17-5 | 21-3 | 24-8 |
| | Douglas fir-larch | #1 | 8-9 | 12-9 | 16-2 | 19-9 | 22-10 | 7-10 | 11-5 | 14-5 | 17-8 | 20-5 |
| | Douglas fir-larch | #2 | 8-2 | 11-11 | 15-1 | 18-5 | 21-5 | 7-3 | 10-8 | 13-6 | 16-6 | 19-2 |
| | Douglas fir-larch | #3 | 6-2 | 9-0 | 11-5 | 13-11 | 16-2 | 5-6 | 8-1 | 10-3 | 12-6 | 14-6 |
| | Hem-fir | SS | 8-7 | 13-6 | 17-10 | 22-9 | Note b | 8-7 | 13-6 | 17-1 | 20-10 | 24-2 |
| | Hem-fir | #1 | 8-5 | 12-5 | 15-9 | 19-3 | 22-3 | 7-7 | 11-1 | 14-1 | 17-2 | 19-11 |
| | Hem-fir | #2 | 8-0 | 11-9 | 14-11 | 18-2 | 21-1 | 7-2 | 10-6 | 13-4 | 16-3 | 18-10 |
| | Hem-fir | #3 | 6-2 | 9-0 | 11-5 | 13-11 | 16-2 | 5-6 | 8-1 | 10-3 | 12-6 | 14-6 |
| | Southern pine | SS | 8-11 | 14-1 | 18-6 | 23-8 | Note b | 8-11 | 14-1 | 18-6 | 23-8 | Note b |
| | Southern pine | #1 | 8-9 | 13-9 | 18-1 | 21-5 | 25-7 | 8-8 | 12-10 | 16-2 | 19-2 | 22-10 |
| | Southern pine | #2 | 8-7 | 12-6 | 16-2 | 19-3 | 22-7 | 7-10 | 11-2 | 14-5 | 17-3 | 20-2 |
| | Southern pine | #3 | 6-7 | 9-8 | 12-4 | 14-7 | 17-4 | 5-10 | 8-8 | 11-0 | 13-0 | 15-6 |
| | Spruce-pine-fir | SS | 8-5 | 13-3 | 17-5 | 22-1 | 25-7 | 8-5 | 12-9 | 16-2 | 19-9 | 22-10 |
| | Spruce-pine-fir | #1 | 8-2 | 11-11 | 15-1 | 18-5 | 21-5 | 7-3 | 10-8 | 13-6 | 16-6 | 19-2 |
| | Spruce-pine-fir | #2 | 8-2 | 11-11 | 15-1 | 18-5 | 21-5 | 7-3 | 10-8 | 13-6 | 16-6 | 19-2 |
| Spruce-pine-fir | #3 | 6-2 | 9-0 | 11-5 | 13-11 | 16-2 | 5-6 | 8-1 | 10-3 | 12-6 | 14-6 | |
| 19.2 | Douglas fir-larch | SS | 8-7 | 13-6 | 17-9 | 21-8 | 25-2 | 8-7 | 12-6 | 15-10 | 19-5 | 22-6 |
| | Douglas fir-larch | #1 | 7-11 | 11-8 | 14-9 | 18-0 | 20-11 | 7-1 | 10-5 | 13-2 | 16-1 | 18-8 |
| | Douglas fir-larch | #2 | 7-5 | 10-11 | 13-9 | 16-10 | 19-6 | 6-8 | 9-9 | 12-4 | 15-1 | 17-6 |
| | Douglas fir-larch | #3 | 5-7 | 8-3 | 10-5 | 12-9 | 14-9 | 5-0 | 7-4 | 9-4 | 11-5 | 13-2 |
| | Hem-fir | SS | 8-1 | 12-9 | 16-9 | 21-4 | 24-8 | 8-1 | 12-4 | 15-7 | 19-1 | 22-1 |
| | Hem-fir | #1 | 7-9 | 11-4 | 14-4 | 17-7 | 20-4 | 6-11 | 10-2 | 12-10 | 15-8 | 18-2 |
| | Hem-fir | #2 | 7-4 | 10-9 | 13-7 | 16-7 | 19-3 | 6-7 | 9-7 | 12-2 | 14-10 | 17-3 |
| | Hem-fir | #3 | 5-7 | 8-3 | 10-5 | 12-9 | 14-9 | 5-0 | 7-4 | 9-4 | 11-5 | 13-2 |
| | Southern pine | SS | 8-5 | 13-3 | 17-5 | 22-3 | Note b | 8-5 | 13-3 | 17-5 | 22-0 | 25-9 |
| | Southern pine | #1 | 8-3 | 13-0 | 16-6 | 19-7 | 23-4 | 7-11 | 11-9 | 14-9 | 17-6 | 20-11 |
| | Southern pine | #2 | 7-11 | 11-5 | 14-9 | 17-7 | 20-7 | 7-1 | 10-2 | 13-2 | 15-9 | 18-5 |
| | Southern pine | #3 | 6-0 | 8-10 | 11-3 | 13-4 | 15-10 | 5-4 | 7-11 | 10-1 | 11-11 | 14-2 |
| | Spruce-pine-fir | SS | 7-11 | 12-5 | 16-5 | 20-2 | 23-4 | 7-11 | 11-8 | 14-9 | 18-0 | 20-11 |
| | Spruce-pine-fir | #1 | 7-5 | 10-11 | 13-9 | 16-10 | 19-6 | 6-8 | 9-9 | 12-4 | 15-1 | 17-6 |
| | Spruce-pine-fir | #2 | 7-5 | 10-11 | 13-9 | 16-10 | 19-6 | 6-8 | 9-9 | 12-4 | 15-1 | 17-6 |
| Spruce-pine-fir | #3 | 5-7 | 8-3 | 10-5 | 12-9 | 14-9 | 5-0 | 7-4 | 9-4 | 11-5 | 13-2 | |

(continued)

TABLE R802.5.1(3)—continued
RAFTER SPANS FOR COMMON LUMBER SPECIES
 (Ground snow load=30 psf, ceiling not attached to rafters, $L/\Delta = 180$)

| RAFTER SPACING (inches) | SPECIES AND GRADE | | DEAD LOAD = 10 psf | | | | | DEAD LOAD = 20 psf | | | | |
|-------------------------|-------------------|----|-----------------------------------|-----------------|-----------------|-----------------|-----------------|--------------------|-----------------|-----------------|-----------------|-----------------|
| | | | 2 x 4 | 2 x 6 | 2 x 8 | 2 x 10 | 2 x 12 | 2 x 4 | 2 x 6 | 2 x 8 | 2 x 10 | 2 x 12 |
| | | | Maximum rafter spans ^a | | | | | | | | | |
| | | | (feet - inches) | (feet - inches) | (feet - inches) | (feet - inches) | (feet - inches) | (feet - inches) | (feet - inches) | (feet - inches) | (feet - inches) | (feet - inches) |
| 24 | Douglas fir-larch | SS | 7-11 | 12-6 | 15-10 | 19-5 | 22-6 | 7-8 | 11-3 | 14-2 | 17-4 | 20-1 |
| | Douglas fir-larch | #1 | 7-1 | 10-5 | 13-2 | 16-1 | 18-8 | 6-4 | 9-4 | 11-9 | 14-5 | 16-8 |
| | Douglas fir-larch | #2 | 6-8 | 9-9 | 12-4 | 15-1 | 17-6 | 5-11 | 8-8 | 11-0 | 13-6 | 15-7 |
| | Douglas fir-larch | #3 | 5-0 | 7-4 | 9-4 | 11-5 | 13-2 | 4-6 | 6-7 | 8-4 | 10-2 | 11-10 |
| | Hem-fir | SS | 7-6 | 11-10 | 15-7 | 19-1 | 22-1 | 7-6 | 11-0 | 13-11 | 17-0 | 19-9 |
| | Hem-fir | #1 | 6-11 | 10-2 | 12-10 | 15-8 | 18-2 | 6-2 | 9-1 | 11-6 | 14-0 | 16-3 |
| | Hem-fir | #2 | 6-7 | 9-7 | 12-2 | 14-10 | 17-3 | 5-10 | 8-7 | 10-10 | 13-3 | 15-5 |
| | Hem-fir | #3 | 5-0 | 7-4 | 9-4 | 11-5 | 13-2 | 4-6 | 6-7 | 8-4 | 10-2 | 11-10 |
| | Southern pine | SS | 7-10 | 12-3 | 16-2 | 20-8 | 25-1 | 7-10 | 12-3 | 16-2 | 19-8 | 23-0 |
| | Southern pine | #1 | 7-8 | 11-9 | 14-9 | 17-6 | 20-11 | 7-1 | 10-6 | 13-2 | 15-8 | 18-8 |
| | Southern pine | #2 | 7-1 | 10-2 | 13-2 | 15-9 | 18-5 | 6-4 | 9-2 | 11-9 | 14-1 | 16-6 |
| | Southern pine | #3 | 5-4 | 7-11 | 10-1 | 11-11 | 14-2 | 4-9 | 7-1 | 9-0 | 10-8 | 12-8 |
| | Spruce-pine-fir | SS | 7-4 | 11-7 | 14-9 | 18-0 | 20-11 | 7-1 | 10-5 | 13-2 | 16-1 | 18-8 |
| | Spruce-pine-fir | #1 | 6-8 | 9-9 | 12-4 | 15-1 | 17-6 | 5-11 | 8-8 | 11-0 | 13-6 | 15-7 |
| | Spruce-pine-fir | #2 | 6-8 | 9-9 | 12-4 | 15-1 | 17-6 | 5-11 | 8-8 | 11-0 | 13-6 | 15-7 |
| | Spruce-pine-fir | #3 | 5-0 | 7-4 | 9-4 | 11-5 | 13-2 | 4-6 | 6-7 | 8-4 | 10-2 | 11-10 |

Check sources for availability of lumber in lengths greater than 20 feet.

For SI: 1 inch = 25.4 mm, 1 foot = 304.8 mm, 1 pound per square foot = 0.0479kPa.

- a. The tabulated rafter spans assume that ceiling joists are located at the bottom of the attic space or that some other method of resisting the outward push of the rafters on the bearing walls, such as rafter ties, is provided at that location. When ceiling joists or rafter ties are located higher in the attic space, the rafter spans shall be multiplied by the factors given below:

| H_C/H_R | Rafter Span Adjustment Factor |
|---------------|-------------------------------|
| 1/3 | 0.67 |
| 1/4 | 0.76 |
| 1/5 | 0.83 |
| 1/6 | 0.90 |
| 1/7.5 or less | 1.00 |

where:

H_C = Height of ceiling joists or rafter ties measured vertically above the top of the rafter support walls.

H_R = Height of roof ridge measured vertically above the top of the rafter support walls.

- b. Span exceeds 26 feet in length.

TABLE R802.5.1(4)
RAFTER SPANS FOR COMMON LUMBER SPECIES
 (Ground snow load=50 psf, ceiling not attached to rafters, L/Δ = 180)

| RAFTER SPACING (inches) | SPECIES AND GRADE | DEAD LOAD = 10 psf | | | | | DEAD LOAD = 20 psf | | | | | |
|-------------------------|-------------------|-----------------------------------|-----------------|-----------------|-----------------|-----------------|--------------------|-----------------|-----------------|-----------------|-----------------|-----------------|
| | | 2 x 4 | 2 x 6 | 2 x 8 | 2 x 10 | 2 x 12 | 2 x 4 | 2 x 6 | 2 x 8 | 2 x 10 | 2 x 12 | |
| | | Maximum rafter spans ^a | | | | | | | | | | |
| | | (feet - inches) | (feet - inches) | (feet - inches) | (feet - inches) | (feet - inches) | (feet - inches) | (feet - inches) | (feet - inches) | (feet - inches) | (feet - inches) | (feet - inches) |
| 12 | Douglas fir-larch | SS | 8-5 | 13-3 | 17-6 | 22-4 | 26-0 | 8-5 | 13-3 | 17-0 | 20-9 | 24-0 |
| | Douglas fir-larch | #1 | 8-2 | 12-0 | 15-3 | 18-7 | 21-7 | 7-7 | 11-2 | 14-1 | 17-3 | 20-0 |
| | Douglas fir-larch | #2 | 7-8 | 11-3 | 14-3 | 17-5 | 20-2 | 7-1 | 10-5 | 13-2 | 16-1 | 18-8 |
| | Douglas fir-larch | #3 | 5-10 | 8-6 | 10-9 | 13-2 | 15-3 | 5-5 | 7-10 | 10-0 | 12-2 | 14-1 |
| | Hem-fir | SS | 8-0 | 12-6 | 16-6 | 21-1 | 25-6 | 8-0 | 12-6 | 16-6 | 20-4 | 23-7 |
| | Hem-fir | #1 | 7-10 | 11-9 | 14-10 | 18-1 | 21-0 | 7-5 | 10-10 | 13-9 | 16-9 | 19-5 |
| | Hem-fir | #2 | 7-5 | 11-1 | 14-0 | 17-2 | 19-11 | 7-0 | 10-3 | 13-0 | 15-10 | 18-5 |
| | Hem-fir | #3 | 5-10 | 8-6 | 10-9 | 13-2 | 15-3 | 5-5 | 7-10 | 10-0 | 12-2 | 14-1 |
| | Southern pine | SS | 8-4 | 13-0 | 17-2 | 21-11 | Note b | 8-4 | 13-0 | 17-2 | 21-11 | Note b |
| | Southern pine | #1 | 8-2 | 12-10 | 16-10 | 20-3 | 24-1 | 8-2 | 12-6 | 15-9 | 18-9 | 22-4 |
| | Southern pine | #2 | 8-0 | 11-9 | 15-3 | 18-2 | 21-3 | 7-7 | 10-11 | 14-1 | 16-10 | 19-9 |
| | Southern pine | #3 | 6-2 | 9-2 | 11-8 | 13-9 | 16-4 | 5-9 | 8-5 | 10-9 | 12-9 | 15-2 |
| | Spruce-pine-fir | SS | 7-10 | 12-3 | 16-2 | 20-8 | 24-1 | 7-10 | 12-3 | 15-9 | 19-3 | 22-4 |
| | Spruce-pine-fir | #1 | 7-8 | 11-3 | 14-3 | 17-5 | 20-2 | 7-1 | 10-5 | 13-2 | 16-1 | 18-8 |
| | Spruce-pine-fir | #2 | 7-8 | 11-3 | 14-3 | 17-5 | 15-2 | 7-1 | 10-5 | 13-2 | 16-1 | 18-8 |
| Spruce-pine-fir | #3 | 5-10 | 8-6 | 10-9 | 13-2 | 20-3 | 5-5 | 7-10 | 10-0 | 12-2 | 14-1 | |
| 16 | Douglas fir-larch | SS | 7-8 | 12-1 | 15-10 | 19-5 | 22-6 | 7-8 | 11-7 | 14-8 | 17-11 | 20-10 |
| | Douglas fir-larch | #1 | 7-1 | 10-5 | 13-2 | 16-1 | 18-8 | 6-7 | 9-8 | 12-2 | 14-11 | 17-3 |
| | Douglas fir-larch | #2 | 6-8 | 9-9 | 12-4 | 15-1 | 17-6 | 6-2 | 9-0 | 11-5 | 13-11 | 16-2 |
| | Douglas fir-larch | #3 | 5-0 | 7-4 | 9-4 | 11-5 | 13-2 | 4-8 | 6-10 | 8-8 | 10-6 | 12-3 |
| | Hem-fir | SS | 7-3 | 11-5 | 15-0 | 19-1 | 22-1 | 7-3 | 11-5 | 14-5 | 17-8 | 20-5 |
| | Hem-fir | #1 | 6-11 | 10-2 | 12-10 | 15-8 | 18-2 | 6-5 | 9-5 | 11-11 | 14-6 | 16-10 |
| | Hem-fir | #2 | 6-7 | 9-7 | 12-2 | 14-10 | 17-3 | 6-1 | 8-11 | 11-3 | 13-9 | 15-11 |
| | Hem-fir | #3 | 5-0 | 7-4 | 9-4 | 11-5 | 13-2 | 4-8 | 6-10 | 8-8 | 10-6 | 12-3 |
| | Southern pine | SS | 7-6 | 11-10 | 15-7 | 19-11 | 24-3 | 7-6 | 11-10 | 15-7 | 19-11 | 23-10 |
| | Southern pine | #1 | 7-5 | 11-7 | 14-9 | 17-6 | 20-11 | 7-4 | 10-10 | 13-8 | 16-2 | 19-4 |
| | Southern pine | #2 | 7-1 | 10-2 | 13-2 | 15-9 | 18-5 | 6-7 | 9-5 | 12-2 | 14-7 | 17-1 |
| | Southern pine | #3 | 5-4 | 7-11 | 10-1 | 11-11 | 14-2 | 4-11 | 7-4 | 9-4 | 11-0 | 13-1 |
| | Spruce-pine-fir | SS | 7-1 | 11-2 | 14-8 | 18-0 | 20-11 | 7-1 | 10-9 | 13-8 | 15-11 | 19-4 |
| | Spruce-pine-fir | #1 | 6-8 | 9-9 | 12-4 | 15-1 | 17-6 | 6-2 | 9-0 | 11-5 | 13-11 | 16-2 |
| | Spruce-pine-fir | #2 | 6-8 | 9-9 | 12-4 | 15-1 | 17-6 | 6-2 | 9-0 | 11-5 | 13-11 | 16-2 |
| Spruce-pine-fir | #3 | 5-0 | 7-4 | 9-4 | 11-5 | 13-2 | 4-8 | 6-10 | 8-8 | 10-6 | 12-3 | |
| 19.2 | Douglas fir-larch | SS | 7-3 | 11-4 | 14-6 | 17-8 | 20-6 | 7-3 | 10-7 | 13-5 | 16-5 | 19-0 |
| | Douglas fir-larch | #1 | 6-6 | 9-6 | 12-0 | 14-8 | 17-1 | 6-0 | 8-10 | 11-2 | 13-7 | 15-9 |
| | Douglas fir-larch | #2 | 6-1 | 8-11 | 11-3 | 13-9 | 15-11 | 5-7 | 8-3 | 10-5 | 12-9 | 14-9 |
| | Douglas fir-larch | #3 | 4-7 | 6-9 | 8-6 | 10-5 | 12-1 | 4-3 | 6-3 | 7-11 | 9-7 | 11-2 |
| | Hem-fir | SS | 6-10 | 10-9 | 14-2 | 17-5 | 20-2 | 6-10 | 10-5 | 13-2 | 16-1 | 18-8 |
| | Hem-fir | #1 | 6-4 | 9-3 | 11-9 | 14-4 | 16-7 | 5-10 | 8-7 | 10-10 | 13-3 | 15-5 |
| | Hem-fir | #2 | 6-0 | 8-9 | 11-1 | 13-7 | 15-9 | 5-7 | 8-1 | 10-3 | 12-7 | 14-7 |
| | Hem-fir | #3 | 4-7 | 6-9 | 8-6 | 10-5 | 12-1 | 4-3 | 6-3 | 7-11 | 9-7 | 11-2 |
| | Southern pine | SS | 7-1 | 11-2 | 14-8 | 18-9 | 22-10 | 7-1 | 11-2 | 14-8 | 18-7 | 21-9 |
| | Southern pine | #1 | 7-0 | 10-8 | 13-5 | 16-0 | 19-1 | 6-8 | 9-11 | 12-5 | 14-10 | 17-8 |
| | Southern pine | #2 | 6-6 | 9-4 | 12-0 | 14-4 | 16-10 | 6-0 | 8-8 | 11-2 | 13-4 | 15-7 |
| | Southern pine | #3 | 4-11 | 7-3 | 9-2 | 10-10 | 12-11 | 4-6 | 6-8 | 8-6 | 10-1 | 12-0 |
| | Spruce-pine-fir | SS | 6-8 | 10-6 | 13-5 | 16-5 | 19-1 | 6-8 | 9-10 | 12-5 | 15-3 | 17-8 |
| | Spruce-pine-fir | #1 | 6-1 | 8-11 | 11-3 | 13-9 | 15-11 | 5-7 | 8-3 | 10-5 | 12-9 | 14-9 |
| | Spruce-pine-fir | #2 | 6-1 | 8-11 | 11-3 | 13-9 | 15-11 | 5-7 | 8-3 | 10-5 | 12-9 | 14-9 |
| Spruce-pine-fir | #3 | 4-7 | 6-9 | 8-6 | 10-5 | 12-1 | 4-3 | 6-3 | 7-11 | 9-7 | 11-2 | |

(continued)

TABLE R802.5.1(4)—continued
RAFTER SPANS FOR COMMON LUMBER SPECIES
 (Ground snow load=50 psf, ceiling not attached to rafters, $L/\Delta = 180$)

| RAFTER SPACING (inches) | SPECIES AND GRADE | | DEAD LOAD = 10 psf | | | | | DEAD LOAD = 20 psf | | | | |
|-------------------------|-------------------|----|-----------------------------------|-----------------|-----------------|-----------------|-----------------|--------------------|-----------------|-----------------|-----------------|-----------------|
| | | | 2 x 4 | 2 x 6 | 2 x 8 | 2 x 10 | 2 x 12 | 2 x 4 | 2 x 6 | 2 x 8 | 2 x 10 | 2 x 12 |
| | | | Maximum rafter spans ^a | | | | | | | | | |
| | | | (feet - inches) | (feet - inches) | (feet - inches) | (feet - inches) | (feet - inches) | (feet - inches) | (feet - inches) | (feet - inches) | (feet - inches) | (feet - inches) |
| 24 | Douglas fir-larch | SS | 6-8 | 10- | 13-0 | 15-10 | 18-4 | 6-6 | 9-6 | 12-0 | 14-8 | 17-0 |
| | Douglas fir-larch | #1 | 5-10 | 8-6 | 10-9 | 13-2 | 15-3 | 5-5 | 7-10 | 10-0 | 12-2 | 14-1 |
| | Douglas fir-larch | #2 | 5-5 | 7-11 | 10-1 | 12-4 | 14-3 | 5-0 | 7-4 | 9-4 | 11-5 | 13-2 |
| | Douglas fir-larch | #3 | 4-1 | 6-0 | 7-7 | 9-4 | 10-9 | 3-10 | 5-7 | 7-1 | 8-7 | 10-0 |
| | Hem-fir | SS | 6-4 | 9-11 | 12-9 | 15-7 | 18-0 | 6-4 | 9-4 | 11-9 | 14-5 | 16-8 |
| | Hem-fir | #1 | 5-8 | 8-3 | 10-6 | 12-10 | 14-10 | 5-3 | 7-8 | 9-9 | 11-10 | 13-9 |
| | Hem-fir | #2 | 5-4 | 7-10 | 9-11 | 12-1 | 14-1 | 4-11 | 7-3 | 9-2 | 11-3 | 13-0 |
| | Hem-fir | #3 | 4-1 | 6-0 | 7-7 | 9-4 | 10-9 | 3-10 | 5-7 | 7-1 | 8-7 | 10-0 |
| | Southern pine | SS | 6-7 | 10-4 | 13-8 | 17-5 | 21-0 | 6-7 | 10-4 | 13-8 | 16-7 | 19-5 |
| | Southern pine | #1 | 6-5 | 9-7 | 12-0 | 14-4 | 17-1 | 6-0 | 8-10 | 11-2 | 13-3 | 15-9 |
| | Southern pine | #2 | 5-10 | 8-4 | 10-9 | 12-10 | 15-1 | 5-5 | 7-9 | 10-0 | 11-11 | 13-11 |
| | Southern pine | #3 | 4-4 | 6-5 | 8-3 | 9-9 | 11-7 | 4-1 | 6-0 | 7-7 | 9-0 | 10-8 |
| | Spruce-pine-fir | SS | 6-2 | 9-6 | 12-0 | 14-8 | 17-1 | 6-0 | 8-10 | 11-2 | 13-7 | 15-9 |
| | Spruce-pine-fir | #1 | 5-5 | 7-11 | 10-1 | 12-4 | 14-3 | 5-0 | 7-4 | 9-4 | 11-5 | 13-2 |
| | Spruce-pine-fir | #2 | 5-5 | 7-11 | 10-1 | 12-4 | 14-3 | 5-0 | 7-4 | 9-4 | 11-5 | 13-2 |
| | Spruce-pine-fir | #3 | 4-1 | 6-0 | 7-7 | 9-4 | 10-9 | 3-10 | 5-7 | 7-1 | 8-7 | 10-0 |

Check sources for availability of lumber in lengths greater than 20 feet.

For SI: 1 inch = 25.4 mm, 1 foot = 304.8 mm, 1 pound per square foot = 0.0479kPa.

- a. The tabulated rafter spans assume that ceiling joists are located at the bottom of the attic space or that some other method of resisting the outward push of the rafters on the bearing walls, such as rafter ties, is provided at that location. When ceiling joists or rafter ties are located higher in the attic space, the rafter spans shall be multiplied by the factors given below:

| H_C/H_R | Rafter Span Adjustment Factor |
|---------------|-------------------------------|
| 1/3 | 0.67 |
| 1/4 | 0.76 |
| 1/5 | 0.83 |
| 1/6 | 0.90 |
| 1/7.5 or less | 1.00 |

where:

H_C = Height of ceiling joists or rafter ties measured vertically above the top of the rafter support walls.

H_R = Height of roof ridge measured vertically above the top of the rafter support walls.

- b. Span exceeds 26 feet in length.

TABLE R802.5.1(5)
RAFTER SPANS FOR COMMON LUMBER SPECIES
 (Ground snow load=30 psf, ceiling attached to rafters, L/Δ = 240)

| RAFTER SPACING (inches) | SPECIES AND GRADE | DEAD LOAD = 10 psf | | | | | DEAD LOAD = 20 psf | | | | | |
|-------------------------|-------------------|-----------------------------------|-----------------|-----------------|-----------------|-----------------|--------------------|-----------------|-----------------|-----------------|-----------------|--------|
| | | 2 x 4 | 2 x 6 | 2 x 8 | 2 x 10 | 2 x 12 | 2 x 4 | 2 x 6 | 2 x 8 | 2 x 10 | 2 x 12 | |
| | | Maximum rafter spans ^a | | | | | | | | | | |
| | | (feet - inches) | (feet - inches) | (feet - inches) | (feet - inches) | (feet - inches) | (feet - inches) | (feet - inches) | (feet - inches) | (feet - inches) | (feet - inches) | |
| 12 | Douglas fir-larch | SS | 9-1 | 14-4 | 18-10 | 24-1 | Note b | 9-1 | 14-4 | 18-10 | 24-1 | Note b |
| | Douglas fir-larch | #1 | 8-9 | 13-9 | 18-2 | 22-9 | Note b | 8-9 | 13-2 | 16-8 | 20-4 | 23-7 |
| | Douglas fir-larch | #2 | 8-7 | 13-6 | 17-5 | 21-4 | 24-8 | 8-5 | 12-4 | 15-7 | 19-1 | 22-1 |
| | Douglas fir-larch | #3 | 7-1 | 10-5 | 13-2 | 16-1 | 18-8 | 6-4 | 9-4 | 11-9 | 14-5 | 16-8 |
| | Hem-fir | SS | 8-7 | 13-6 | 17-10 | 22-9 | Note b | 8-7 | 13-6 | 17-10 | 22-9 | Note b |
| | Hem-fir | #1 | 8-5 | 13-3 | 17-5 | 22-2 | 25-9 | 8-5 | 12-10 | 16-3 | 19-10 | 23-0 |
| | Hem-fir | #2 | 8-0 | 12-7 | 16-7 | 21-0 | 24-4 | 8-0 | 12-2 | 15-4 | 18-9 | 21-9 |
| | Hem-fir | #3 | 7-1 | 10-5 | 13-2 | 16-1 | 18-8 | 6-4 | 9-4 | 11-9 | 14-5 | 16-8 |
| | Southern pine | SS | 8-11 | 14-1 | 18-6 | 23-8 | Note b | 8-11 | 14-1 | 18-6 | 23-8 | Note b |
| | Southern pine | #1 | 8-9 | 13-9 | 18-2 | 23-2 | Note b | 8-9 | 13-9 | 18-2 | 22-2 | Note b |
| | Southern pine | #2 | 8-7 | 13-6 | 17-10 | 22-3 | Note b | 8-7 | 12-11 | 16-8 | 19-11 | 23-4 |
| | Southern pine | #3 | 7-7 | 11-2 | 14-3 | 16-10 | 20-0 | 6-9 | 10-0 | 12-9 | 15-1 | 17-11 |
| | Spruce-pine-fir | SS | 8-5 | 13-3 | 17-5 | 22-3 | Note b | 8-5 | 13-3 | 17-5 | 22-3 | Note b |
| | Spruce-pine-fir | #1 | 8-3 | 12-11 | 17-0 | 21-4 | 24-8 | 8-3 | 12-4 | 15-7 | 19-1 | 22-1 |
| | Spruce-pine-fir | #2 | 8-3 | 12-11 | 17-0 | 21-4 | 24-8 | 8-3 | 12-4 | 15-7 | 19-1 | 22-1 |
| Spruce-pine-fir | #3 | 7-1 | 10-5 | 13-2 | 16-1 | 18-8 | 6-4 | 9-4 | 11-9 | 14-5 | 16-8 | |
| 16 | Douglas fir-larch | SS | 8-3 | 13-0 | 17-2 | 21-10 | Note b | 8-3 | 13-0 | 17-2 | 21-3 | 24-8 |
| | Douglas fir-larch | #1 | 8-0 | 12-6 | 16-2 | 19-9 | 22-10 | 7-10 | 11-5 | 14-5 | 17-8 | 20-5 |
| | Douglas fir-larch | #2 | 7-10 | 11-11 | 15-1 | 18-5 | 21-5 | 7-3 | 10-8 | 13-6 | 16-6 | 19-2 |
| | Douglas fir-larch | #3 | 6-2 | 9-0 | 11-5 | 13-11 | 16-2 | 5-6 | 8-1 | 10-3 | 12-6 | 14-6 |
| | Hem-fir | SS | 7-10 | 12-3 | 16-2 | 20-8 | 25-1 | 7-10 | 12-3 | 16-2 | 20-8 | 24-2 |
| | Hem-fir | #1 | 7-8 | 12-0 | 15-9 | 19-3 | 22-3 | 7-7 | 11-1 | 14-1 | 17-2 | 19-11 |
| | Hem-fir | #2 | 7-3 | 11-5 | 14-11 | 18-2 | 21-1 | 7-2 | 10-6 | 13-4 | 16-3 | 18-10 |
| | Hem-fir | #3 | 6-2 | 9-0 | 11-5 | 13-11 | 16-2 | 5-6 | 8-1 | 10-3 | 12-6 | 14-6 |
| | Southern pine | SS | 8-1 | 12-9 | 16-10 | 21-6 | Note b | 8-1 | 12-9 | 16-10 | 21-6 | Note b |
| | Southern pine | #1 | 8-0 | 12-6 | 16-6 | 21-1 | 25-7 | 8-0 | 12-6 | 16-2 | 19-2 | 22-10 |
| | Southern pine | #2 | 7-10 | 12-3 | 16-2 | 19-3 | 22-7 | 7-10 | 11-2 | 14-5 | 17-3 | 20-2 |
| | Southern pine | #3 | 6-7 | 9-8 | 12-4 | 14-7 | 17-4 | 5-10 | 8-8 | 11-0 | 13-0 | 15-6 |
| | Spruce-pine-fir | SS | 7-8 | 12-0 | 15-10 | 20-2 | 24-7 | 7-8 | 12-0 | 15-10 | 19-9 | 22-10 |
| | Spruce-pine-fir | #1 | 7-6 | 11-9 | 15-1 | 18-5 | 21-5 | 7-3 | 10-8 | 13-6 | 16-6 | 19-2 |
| | Spruce-pine-fir | #2 | 7-6 | 11-9 | 15-1 | 18-5 | 21-5 | 7-3 | 10-8 | 13-6 | 16-6 | 19-2 |
| Spruce-pine-fir | #3 | 6-2 | 9-0 | 11-5 | 13-11 | 16-2 | 5-6 | 8-1 | 10-3 | 12-6 | 14-6 | |
| 19.2 | Douglas fir-larch | SS | 7-9 | 12-3 | 16-1 | 20-7 | 25-0 | 7-9 | 12-3 | 15-10 | 19-5 | 22-6 |
| | Douglas fir-larch | #1 | 7-6 | 11-8 | 14-9 | 18-0 | 20-11 | 7-1 | 10-5 | 13-2 | 16-1 | 18-8 |
| | Douglas fir-larch | #2 | 7-4 | 10-11 | 13-9 | 16-10 | 19-6 | 6-8 | 9-9 | 12-4 | 15-1 | 17-6 |
| | Douglas fir-larch | #3 | 5-7 | 8-3 | 10-5 | 12-9 | 14-9 | 5-0 | 7-4 | 9-4 | 11-5 | 13-2 |
| | Hem-fir | SS | 7-4 | 11-7 | 15-3 | 19-5 | 23-7 | 7-4 | 11-7 | 15-3 | 19-1 | 22-1 |
| | Hem-fir | #1 | 7-2 | 11-4 | 14-4 | 17-7 | 20-4 | 6-11 | 10-2 | 12-10 | 15-8 | 18-2 |
| | Hem-fir | #2 | 6-10 | 10-9 | 13-7 | 16-7 | 19-3 | 6-7 | 9-7 | 12-2 | 14-10 | 17-3 |
| | Hem-fir | #3 | 5-7 | 8-3 | 10-5 | 12-9 | 14-9 | 5-0 | 7-4 | 9-4 | 11-5 | 13-2 |
| | Southern pine | SS | 7-8 | 12-0 | 15-10 | 20-2 | 24-7 | 7-8 | 12-0 | 15-10 | 20-2 | 24-7 |
| | Southern pine | #1 | 7-6 | 11-9 | 15-6 | 19-7 | 23-4 | 7-6 | 11-9 | 14-9 | 17-6 | 20-11 |
| | Southern pine | #2 | 7-4 | 11-5 | 14-9 | 17-7 | 20-7 | 7-1 | 10-2 | 13-2 | 15-9 | 18-5 |
| | Southern pine | #3 | 6-0 | 8-10 | 11-3 | 13-4 | 15-10 | 5-4 | 7-11 | 10-1 | 11-11 | 14-2 |
| | Spruce-pine-fir | SS | 7-2 | 11-4 | 14-11 | 19-0 | 23-1 | 7-2 | 11-4 | 14-9 | 18-0 | 20-11 |
| | Spruce-pine-fir | #1 | 7-0 | 10-11 | 13-9 | 16-10 | 19-6 | 6-8 | 9-9 | 12-4 | 15-1 | 17-6 |
| | Spruce-pine-fir | #2 | 7-0 | 10-11 | 13-9 | 16-10 | 19-6 | 6-8 | 9-9 | 12-4 | 15-1 | 17-6 |
| Spruce-pine-fir | #3 | 5-7 | 8-3 | 10-5 | 12-9 | 14-9 | 5-0 | 7-4 | 9-4 | 11-5 | 13-2 | |

(continued)

TABLE R802.5.1(5)—continued
RAFTER SPANS FOR COMMON LUMBER SPECIES
 (Ground snow load=30 psf, ceiling attached to rafters, $L/\Delta = 240$)

| RAFTER SPACING (inches) | SPECIES AND GRADE | | DEAD LOAD = 10 psf | | | | | DEAD LOAD = 20 psf | | | | |
|-------------------------|-------------------|----|-----------------------------------|---------------|---------------|---------------|---------------|--------------------|---------------|---------------|---------------|---------------|
| | | | 2 x 4 | 2 x 6 | 2 x 8 | 2 x 10 | 2 x 12 | 2 x 4 | 2 x 6 | 2 x 8 | 2 x 10 | 2 x 12 |
| | | | Maximum rafter spans ^a | | | | | | | | | |
| | | | (feet-inches) | (feet-inches) | (feet-inches) | (feet-inches) | (feet-inches) | (feet-inches) | (feet-inches) | (feet-inches) | (feet-inches) | (feet-inches) |
| 24 | Douglas fir-larch | SS | 7-3 | 11-4 | 15-0 | 19-1 | 22-6 | 7-3 | 11-3 | 14-2 | 17-4 | 20-1 |
| | Douglas fir-larch | #1 | 7-0 | 10-5 | 13-2 | 16-1 | 18-8 | 6-4 | 9-4 | 11-9 | 14-5 | 16-8 |
| | Douglas fir-larch | #2 | 6-8 | 9-9 | 12-4 | 15-1 | 17-6 | 5-11 | 8-8 | 11-0 | 13-6 | 15-7 |
| | Douglas fir-larch | #3 | 5-0 | 7-4 | 9-4 | 11-5 | 13-2 | 4-6 | 6-7 | 8-4 | 10-2 | 11-10 |
| | Hem-fir | SS | 6-10 | 10-9 | 14-2 | 18-0 | 21-11 | 6-10 | 10-9 | 13-11 | 17-0 | 19-9 |
| | Hem-fir | #1 | 6-8 | 10-2 | 12-10 | 15-8 | 18-2 | 6-2 | 9-1 | 11-6 | 14-0 | 16-3 |
| | Hem-fir | #2 | 6-4 | 9-7 | 12-2 | 14-10 | 17-3 | 5-10 | 8-7 | 10-10 | 13-3 | 15-5 |
| | Hem-fir | #3 | 5-0 | 7-4 | 9-4 | 11-5 | 13-2 | 4-6 | 6-7 | 8-4 | 10-2 | 11-10 |
| | Southern pine | SS | 7-1 | 11-2 | 14-8 | 18-9 | 22-10 | 7-1 | 11-2 | 14-8 | 18-9 | 22-10 |
| | Southern pine | #1 | 7-0 | 10-11 | 14-5 | 17-6 | 20-11 | 7-0 | 10-6 | 13-2 | 15-8 | 18-8 |
| | Southern pine | #2 | 6-10 | 10-2 | 13-2 | 15-9 | 18-5 | 6-4 | 9-2 | 11-9 | 14-1 | 16-6 |
| | Southern pine | #3 | 5-4 | 7-11 | 10-1 | 11-11 | 14-2 | 4-9 | 7-1 | 9-0 | 10-8 | 12-8 |
| | Spruce-pine-fir | SS | 6-8 | 10-6 | 13-10 | 17-8 | 20-11 | 6-8 | 10-5 | 13-2 | 16-1 | 18-8 |
| | Spruce-pine-fir | #1 | 6-6 | 9-9 | 12-4 | 15-1 | 17-6 | 5-11 | 8-8 | 11-0 | 13-6 | 15-7 |
| | Spruce-pine-fir | #2 | 6-6 | 9-9 | 12-4 | 15-1 | 17-6 | 5-11 | 8-8 | 11-0 | 13-6 | 15-7 |
| | Spruce-pine-fir | #3 | 5-0 | 7-4 | 9-4 | 11-5 | 13-2 | 4-6 | 6-7 | 8-4 | 10-2 | 11-10 |

Check sources for availability of lumber in lengths greater than 20 feet.

For SI: 1 inch = 25.4 mm, 1 foot = 304.8 mm, 1 pound per square foot = 0.0479kPa.

- a. The tabulated rafter spans assume that ceiling joists are located at the bottom of the attic space or that some other method of resisting the outward push of the rafters on the bearing walls, such as rafter ties, is provided at that location. When ceiling joists or rafter ties are located higher in the attic space, the rafter spans shall be multiplied by the factors given below:

| H_C/H_R | Rafter Span Adjustment Factor |
|---------------|-------------------------------|
| 1/3 | 0.67 |
| 1/4 | 0.76 |
| 1/5 | 0.83 |
| 1/6 | 0.90 |
| 1/7.5 or less | 1.00 |

where:

H_C = Height of ceiling joists or rafter ties measured vertically above the top of the rafter support walls.

H_R = Height of roof ridge measured vertically above the top of the rafter support walls.

- b. Span exceeds 26 feet in length.

TABLE R802.5.1(6)
RAFTER SPANS FOR COMMON LUMBER SPECIES
 (Ground snow load=50 psf, ceiling attached to rafters, L/Δ = 240)

| RAFTER SPACING (inches) | SPECIES AND GRADE | DEAD LOAD = 10 psf | | | | | DEAD LOAD = 20 psf | | | | | |
|-------------------------|-------------------|-----------------------------------|---------------|---------------|---------------|---------------|--------------------|---------------|---------------|---------------|---------------|---------------|
| | | 2 x 4 | 2 x 6 | 2 x 8 | 2 x 10 | 2 x 12 | 2 x 4 | 2 x 6 | 2 x 8 | 2 x 10 | 2 x 12 | |
| | | Maximum rafter spans ^a | | | | | | | | | | |
| | | (feet-inches) | (feet-inches) | (feet-inches) | (feet-inches) | (feet-inches) | (feet-inches) | (feet-inches) | (feet-inches) | (feet-inches) | (feet-inches) | (feet-inches) |
| 12 | Douglas fir-larch | SS | 7-8 | 12-1 | 15-11 | 20-3 | 24-8 | 7-8 | 12-1 | 15-11 | 20-3 | 24-0 |
| | Douglas fir-larch | #1 | 7-5 | 11-7 | 15-3 | 18-7 | 21-7 | 7-5 | 11-2 | 14-1 | 17-3 | 20-0 |
| | Douglas fir-larch | #2 | 7-3 | 11-3 | 14-3 | 17-5 | 20-2 | 7-1 | 10-5 | 13-2 | 16-1 | 18-8 |
| | Douglas fir-larch | #3 | 5-10 | 8-6 | 10-9 | 13-2 | 15-3 | 5-5 | 7-10 | 10-0 | 12-2 | 14-1 |
| | Hem-fir | SS | 7-3 | 11-5 | 15-0 | 19-2 | 23-4 | 7-3 | 11-5 | 15-0 | 19-2 | 23-4 |
| | Hem-fir | #1 | 7-1 | 11-2 | 14-8 | 18-1 | 21-0 | 7-1 | 10-10 | 13-9 | 16-9 | 19-5 |
| | Hem-fir | #2 | 6-9 | 10-8 | 14-0 | 17-2 | 19-11 | 6-9 | 10-3 | 13-0 | 15-10 | 18-5 |
| | Hem-fir | #3 | 5-10 | 8-6 | 10-9 | 13-2 | 15-3 | 5-5 | 7-10 | 10-0 | 12-2 | 14-1 |
| | Southern pine | SS | 7-6 | 11-10 | 15-7 | 19-11 | 24-3 | 7-6 | 11-10 | 15-7 | 19-11 | 24-3 |
| | Southern pine | #1 | 7-5 | 11-7 | 15-4 | 19-7 | 23-9 | 7-5 | 11-7 | 15-4 | 18-9 | 22-4 |
| | Southern pine | #2 | 7-3 | 11-5 | 15-0 | 18-2 | 21-3 | 7-3 | 10-11 | 14-1 | 16-10 | 19-9 |
| | Southern pine | #3 | 6-2 | 9-2 | 11-8 | 13-9 | 16-4 | 5-9 | 8-5 | 10-9 | 12-9 | 15-2 |
| | Spruce-pine-fir | SS | 7-1 | 11-2 | 14-8 | 18-9 | 22-10 | 7-1 | 11-2 | 14-8 | 18-9 | 22-4 |
| | Spruce-pine-fir | #1 | 6-11 | 10-11 | 14-3 | 17-5 | 20-2 | 6-11 | 10-5 | 13-2 | 16-1 | 18-8 |
| | Spruce-pine-fir | #2 | 6-11 | 10-11 | 14-3 | 17-5 | 20-2 | 6-11 | 10-5 | 13-2 | 16-1 | 18-8 |
| Spruce-pine-fir | #3 | 5-10 | 8-6 | 10-9 | 13-2 | 15-3 | 5-5 | 7-10 | 10-0 | 12-2 | 14-1 | |
| 16 | Douglas fir-larch | SS | 7-0 | 11-0 | 14-5 | 18-5 | 22-5 | 7-0 | 11-0 | 14-5 | 17-11 | 20-10 |
| | Douglas fir-larch | #1 | 6-9 | 10-5 | 13-2 | 16-1 | 18-8 | 6-7 | 9-8 | 12-2 | 14-11 | 17-3 |
| | Douglas fir-larch | #2 | 6-7 | 9-9 | 12-4 | 15-1 | 17-6 | 6-2 | 9-0 | 11-5 | 13-11 | 16-2 |
| | Douglas fir-larch | #3 | 5-0 | 7-4 | 9-4 | 11-5 | 13-2 | 4-8 | 6-10 | 8-8 | 10-6 | 12-3 |
| | Hem-fir | SS | 6-7 | 10-4 | 13-8 | 17-5 | 21-2 | 6-7 | 10-4 | 13-8 | 17-5 | 20-5 |
| | Hem-fir | #1 | 6-5 | 10-2 | 12-10 | 15-8 | 18-2 | 6-5 | 9-5 | 11-11 | 14-6 | 16-10 |
| | Hem-fir | #2 | 6-2 | 9-7 | 12-2 | 14-10 | 17-3 | 6-1 | 8-11 | 11-3 | 13-9 | 15-11 |
| | Hem-fir | #3 | 5-0 | 7-4 | 9-4 | 11-5 | 13-2 | 4-8 | 6-10 | 8-8 | 10-6 | 12-3 |
| | Southern pine | SS | 6-10 | 10-9 | 14-2 | 18-1 | 22-0 | 6-10 | 10-9 | 14-2 | 18-1 | 22-0 |
| | Southern pine | #1 | 6-9 | 10-7 | 13-11 | 17-6 | 20-11 | 6-9 | 10-7 | 13-8 | 16-2 | 19-4 |
| | Southern pine | #2 | 6-7 | 10-2 | 13-2 | 15-9 | 18-5 | 6-7 | 9-5 | 12-2 | 14-7 | 17-1 |
| | Southern pine | #3 | 5-4 | 7-11 | 10-1 | 11-11 | 14-2 | 4-11 | 7-4 | 9-4 | 11-0 | 13-1 |
| | Spruce-pine-fir | SS | 6-5 | 10-2 | 13-4 | 17-0 | 20-9 | 6-5 | 10-2 | 13-4 | 16-8 | 19-4 |
| | Spruce-pine-fir | #1 | 6-4 | 9-9 | 12-4 | 15-1 | 17-6 | 6-2 | 9-0 | 11-5 | 13-11 | 16-2 |
| | Spruce-pine-fir | #2 | 6-4 | 9-9 | 12-4 | 15-1 | 17-6 | 6-2 | 9-0 | 11-5 | 13-11 | 16-2 |
| Spruce-pine-fir | #3 | 5-0 | 7-4 | 9-4 | 11-5 | 13-2 | 4-8 | 6-10 | 8-8 | 10-6 | 12-3 | |
| 19.2 | Douglas fir-larch | SS | 6-7 | 10-4 | 13-7 | 17-4 | 20-6 | 6-7 | 10-4 | 13-5 | 16-5 | 19-0 |
| | Douglas fir-larch | #1 | 6-4 | 9-6 | 12-0 | 14-8 | 17-1 | 6-0 | 8-10 | 11-2 | 13-7 | 15-9 |
| | Douglas fir-larch | #2 | 6-1 | 8-11 | 11-3 | 13-9 | 15-11 | 5-7 | 8-3 | 10-5 | 12-9 | 14-9 |
| | Douglas fir-larch | #3 | 4-7 | 6-9 | 8-6 | 10-5 | 12-1 | 4-3 | 6-3 | 7-11 | 9-7 | 11-2 |
| | Hem-fir | SS | 6-2 | 9-9 | 12-10 | 16-5 | 19-11 | 6-2 | 9-9 | 12-10 | 16-1 | 18-8 |
| | Hem-fir | #1 | 6-1 | 9-3 | 11-9 | 14-4 | 16-7 | 5-10 | 8-7 | 10-10 | 13-3 | 15-5 |
| | Hem-fir | #2 | 5-9 | 8-9 | 11-1 | 13-7 | 15-9 | 5-7 | 8-1 | 10-3 | 12-7 | 14-7 |
| | Hem-fir | #3 | 4-7 | 6-9 | 8-6 | 10-5 | 12-1 | 4-3 | 6-3 | 7-11 | 9-7 | 11-2 |
| | Southern pine | SS | 6-5 | 10-2 | 13-4 | 17-0 | 20-9 | 6-5 | 10-2 | 13-4 | 17-0 | 20-9 |
| | Southern pine | #1 | 6-4 | 9-11 | 13-1 | 16-0 | 19-1 | 6-4 | 9-11 | 12-5 | 14-10 | 17-8 |
| | Southern pine | #2 | 6-2 | 9-4 | 12-0 | 14-4 | 16-10 | 6-0 | 8-8 | 11-2 | 13-4 | 15-7 |
| | Southern pine | #3 | 4-11 | 7-3 | 9-2 | 10-10 | 12-11 | 4-6 | 6-8 | 8-6 | 10-1 | 12-0 |
| | Spruce-pine-fir | SS | 6-1 | 9-6 | 12-7 | 16-0 | 19-1 | 6-1 | 9-6 | 12-5 | 15-3 | 17-8 |
| | Spruce-pine-fir | #1 | 5-11 | 8-11 | 11-3 | 13-9 | 15-11 | 5-7 | 8-3 | 10-5 | 12-9 | 14-9 |
| | Spruce-pine-fir | #2 | 5-11 | 8-11 | 11-3 | 13-9 | 15-11 | 5-7 | 8-3 | 10-5 | 12-9 | 14-9 |
| Spruce-pine-fir | #3 | 4-7 | 6-9 | 8-6 | 10-5 | 12-1 | 4-3 | 6-3 | 7-11 | 9-7 | 11-2 | |

(continued)

TABLE R802.5.1(6)—continued
RAFTER SPANS FOR COMMON LUMBER SPECIES
 (Ground snow load=50 psf, ceiling attached to rafters, L/Δ = 240)

| RAFTER SPACING (inches) | SPECIES AND GRADE | | DEAD LOAD = 10 psf | | | | | DEAD LOAD = 20 psf | | | | |
|-------------------------|-------------------|----|-----------------------------------|---------------|---------------|---------------|---------------|--------------------|---------------|---------------|---------------|---------------|
| | | | 2 x 4 | 2 x 6 | 2 x 8 | 2 x 10 | 2 x 12 | 2 x 4 | 2 x 6 | 2 x 8 | 2 x 10 | 2 x 12 |
| | | | Maximum rafter spans ^a | | | | | | | | | |
| | | | (feet-inches) | (feet-inches) | (feet-inches) | (feet-inches) | (feet-inches) | (feet-inches) | (feet-inches) | (feet-inches) | (feet-inches) | (feet-inches) |
| 24 | Douglas fir-larch | SS | 6-1 | 9-7 | 12-7 | 15-10 | 18-4 | 6-1 | 9-6 | 12-0 | 14-8 | 17-0 |
| | Douglas fir-larch | #1 | 5-10 | 8-6 | 10-9 | 13-2 | 15-3 | 5-5 | 7-10 | 10-0 | 12-2 | 14-1 |
| | Douglas fir-larch | #2 | 5-5 | 7-11 | 10-1 | 12-4 | 14-3 | 5-0 | 7-4 | 9-4 | 11-5 | 13-2 |
| | Douglas fir-larch | #3 | 4-1 | 6-0 | 7-7 | 9-4 | 10-9 | 3-10 | 5-7 | 7-1 | 8-7 | 10-0 |
| | Hem-fir | SS | 5-9 | 9-1 | 11-11 | 15-2 | 18-0 | 5-9 | 9-1 | 11-9 | 14-5 | 15-11 |
| | Hem-fir | #1 | 5-8 | 8-3 | 10-6 | 12-10 | 14-10 | 5-3 | 7-8 | 9-9 | 11-10 | 13-9 |
| | Hem-fir | #2 | 5-4 | 7-10 | 9-11 | 12-1 | 14-1 | 4-11 | 7-3 | 9-2 | 11-3 | 13-0 |
| | Hem-fir | #3 | 4-1 | 6-0 | 7-7 | 9-4 | 10-9 | 3-10 | 5-7 | 7-1 | 8-7 | 10-0 |
| | Southern pine | SS | 6-0 | 9-5 | 12-5 | 15-10 | 19-3 | 6-0 | 9-5 | 12-5 | 15-10 | 19-3 |
| | Southern pine | #1 | 5-10 | 9-3 | 12-0 | 14-4 | 17-1 | 5-10 | 8-10 | 11-2 | 13-3 | 15-9 |
| | Southern pine | #2 | 5-9 | 8-4 | 10-9 | 12-10 | 15-1 | 5-5 | 7-9 | 10-0 | 11-11 | 13-11 |
| | Southern pine | #3 | 4-4 | 6-5 | 8-3 | 9-9 | 11-7 | 4-1 | 6-0 | 7-7 | 9-0 | 10-8 |
| | Spruce-pine-fir | SS | 5-8 | 8-10 | 11-8 | 14-8 | 17-1 | 5-8 | 8-10 | 11-2 | 13-7 | 15-9 |
| | Spruce-pine-fir | #1 | 5-5 | 7-11 | 10-1 | 12-4 | 14-3 | 5-0 | 7-4 | 9-4 | 11-5 | 13-2 |
| | Spruce-pine-fir | #2 | 5-5 | 7-11 | 10-1 | 12-4 | 14-3 | 5-0 | 7-4 | 9-4 | 11-5 | 13-2 |
| | Spruce-pine-fir | #3 | 4-1 | 6-0 | 7-7 | 9-4 | 10-9 | 3-10 | 5-7 | 7-1 | 8-7 | 10-0 |

Check sources for availability of lumber in lengths greater than 20 feet.

For SI: 1 inch = 25.4 mm, 1 foot = 304.8 mm, 1 pound per square foot = 0.0479kPa.

- a. The tabulated rafter spans assume that ceiling joists are located at the bottom of the attic space or that some other method of resisting the outward push of the rafters on the bearing walls, such as rafter ties, is provided at that location. When ceiling joists or rafter ties are located higher in the attic space, the rafter spans shall be multiplied by the factors given below:

| H_C/H_R | Rafter Span Adjustment Factor |
|---------------|-------------------------------|
| 1/3 | 0.67 |
| 1/4 | 0.76 |
| 1/5 | 0.83 |
| 1/6 | 0.90 |
| 1/7.5 or less | 1.00 |

where:

H_C = Height of ceiling joists or rafter ties measured vertically above the top of the rafter support walls.

H_R = Height of roof ridge measured vertically above the top of the rafter support walls.

TABLE R802.5.1(7)
RAFTER SPANS FOR 70 PSF GROUND SNOW LOAD
(Ceiling not attached to rafters, L/Δ = 180)

| RAFTER SPACING (inches) | SPECIES AND GRADE | DEAD LOAD = 10 psf | | | | | DEAD LOAD = 20 psf | | | | | |
|-------------------------|-------------------|-----------------------------------|---------------|---------------|---------------|---------------|--------------------|---------------|---------------|---------------|---------------|-------|
| | | 2 x 4 | 2 x 6 | 2 x 8 | 2 x 10 | 2 x 12 | 2 x 4 | 2 x 6 | 2 x 8 | 2 x 10 | 2 x 12 | |
| | | Maximum Rafter Spans ^a | | | | | | | | | | |
| | | (feet-inches) | (feet-inches) | (feet-inches) | (feet-inches) | (feet-inches) | (feet-inches) | (feet-inches) | (feet-inches) | (feet-inches) | (feet-inches) | |
| 12 | Douglas fir-larch | SS | 7-7 | 11-10 | 15-8 | 19-5 | 22-6 | 7-7 | 11-10 | 15-0 | 18-3 | 21-2 |
| | Douglas fir-larch | #1 | 7-1 | 10-5 | 13-2 | 16-1 | 18-8 | 6-8 | 9-10 | 12-5 | 15-2 | 17-7 |
| | Douglas fir-larch | #2 | 6-8 | 9-9 | 12-4 | 15-1 | 17-6 | 6-3 | 9-2 | 11-8 | 14-2 | 16-6 |
| | Douglas fir-larch | #3 | 5-0 | 7-4 | 9-4 | 11-5 | 13-2 | 4-9 | 6-11 | 8-9 | 10-9 | 12-5 |
| | Hem-fir | SS | 7-2 | 11-3 | 14-9 | 18-10 | 22-1 | 7-2 | 11-3 | 14-8 | 18-0 | 20-10 |
| | Hem-fir | #1 | 6-11 | 10-2 | 12-10 | 15-8 | 18-2 | 6-6 | 9-7 | 12-1 | 14-10 | 17-2 |
| | Hem-fir | #2 | 6-7 | 9-7 | 12-2 | 14-10 | 17-3 | 6-2 | 9-1 | 11-5 | 14-0 | 16-3 |
| | Hem-fir | #3 | 5-0 | 7-4 | 9-4 | 11-5 | 13-2 | 4-9 | 6-11 | 8-9 | 10-9 | 12-5 |
| | Southern pine | SS | 7-5 | 11-8 | 15-4 | 19-7 | 23-10 | 7-5 | 11-8 | 15-4 | 19-7 | 23-10 |
| | Southern pine | #1 | 7-3 | 11-5 | 14-9 | 17-6 | 20-11 | 7-3 | 11-1 | 13-11 | 16-6 | 19-8 |
| | Southern pine | #2 | 7-1 | 10-2 | 13-2 | 15-9 | 18-5 | 6-8 | 9-7 | 12-5 | 14-10 | 17-5 |
| | Southern pine | #3 | 5-4 | 7-11 | 10-1 | 11-11 | 14-2 | 5-1 | 7-5 | 9-6 | 11-3 | 13-4 |
| | Spruce-pine-fir | SS | 7-0 | 11-0 | 14-6 | 18-0 | 20-11 | 7-0 | 11-0 | 13-11 | 17-0 | 19-8 |
| | Spruce-pine-fir | #1 | 6-8 | 9-9 | 12-4 | 15-1 | 17-6 | 6-3 | 9-2 | 11-8 | 14-2 | 16-6 |
| | Spruce-pine-fir | #2 | 6-8 | 9-9 | 12-4 | 15-1 | 17-6 | 6-3 | 9-2 | 11-8 | 14-2 | 16-6 |
| Spruce-pine-fir | #3 | 5-0 | 7-4 | 9-4 | 11-5 | 13-2 | 4-9 | 6-11 | 8-9 | 10-9 | 12-5 | |
| 16 | Douglas fir-larch | SS | 6-10 | 10-9 | 13-9 | 16-10 | 19-6 | 6-10 | 10-3 | 13-0 | 15-10 | 18-4 |
| | Douglas fir-larch | #1 | 6-2 | 9-0 | 11-5 | 13-11 | 16-2 | 5-10 | 8-6 | 10-9 | 13-2 | 15-3 |
| | Douglas fir-larch | #2 | 5-9 | 8-5 | 10-8 | 13-1 | 15-2 | 5-5 | 7-11 | 10-1 | 12-4 | 14-3 |
| | Douglas fir-larch | #3 | 4-4 | 6-4 | 8-1 | 9-10 | 11-5 | 4-1 | 6-0 | 7-7 | 9-4 | 10-9 |
| | Hem-fir | SS | 6-6 | 10-2 | 13-5 | 16-6 | 19-2 | 6-6 | 10-1 | 12-9 | 15-7 | 18-0 |
| | Hem-fir | #1 | 6-0 | 8-9 | 11-2 | 13-7 | 15-9 | 5-8 | 8-3 | 10-6 | 12-10 | 14-10 |
| | Hem-fir | #2 | 5-8 | 8-4 | 10-6 | 12-10 | 14-11 | 5-4 | 7-10 | 9-11 | 12-1 | 14-1 |
| | Hem-fir | #3 | 4-4 | 6-4 | 8-1 | 9-10 | 11-5 | 4-1 | 6-0 | 7-7 | 9-4 | 10-9 |
| | Southern pine | SS | 6-9 | 10-7 | 14-0 | 17-10 | 21-8 | 6-9 | 10-7 | 14-0 | 17-10 | 21-0 |
| | Southern pine | #1 | 6-7 | 10-2 | 12-9 | 15-2 | 18-1 | 6-5 | 9-7 | 12-0 | 14-4 | 17-1 |
| | Southern pine | #2 | 6-2 | 8-10 | 11-5 | 13-7 | 16-0 | 5-10 | 8-4 | 10-9 | 12-10 | 15-1 |
| | Southern pine | #3 | 4-8 | 6-10 | 8-9 | 10-4 | 12-3 | 4-4 | 6-5 | 8-3 | 9-9 | 11-7 |
| | Spruce-pine-fir | SS | 6-4 | 10-0 | 12-9 | 15-7 | 18-1 | 6-4 | 9-6 | 12-0 | 14-8 | 17-1 |
| | Spruce-pine-fir | #1 | 5-9 | 8-5 | 10-8 | 13-1 | 15-2 | 5-5 | 7-11 | 10-1 | 12-4 | 14-3 |
| | Spruce-pine-fir | #2 | 5-9 | 8-5 | 10-8 | 13-1 | 15-2 | 5-5 | 7-11 | 10-1 | 12-4 | 14-3 |
| Spruce-pine-fir | #3 | 4-4 | 6-4 | 8-1 | 9-10 | 11-5 | 4-1 | 6-0 | 7-7 | 9-4 | 10-9 | |
| 19.2 | Douglas fir-larch | SS | 6-5 | 9-11 | 12-7 | 15-4 | 17-9 | 6-5 | 9-4 | 11-10 | 14-5 | 16-9 |
| | Douglas fir-larch | #1 | 5-7 | 8-3 | 10-5 | 12-9 | 14-9 | 5-4 | 7-9 | 9-10 | 12-0 | 13-11 |
| | Douglas fir-larch | #2 | 5-3 | 7-8 | 9-9 | 11-11 | 13-10 | 5-0 | 7-3 | 9-2 | 11-3 | 13-0 |
| | Douglas fir-larch | #3 | 4-0 | 5-10 | 7-4 | 9-0 | 10-5 | 3-9 | 5-6 | 6-11 | 8-6 | 9-10 |
| | Hem-fir | SS | 6-1 | 9-7 | 12-4 | 15-1 | 17-4 | 6-1 | 9-2 | 11-8 | 14-2 | 15-5 |
| | Hem-fir | #1 | 5-6 | 8-0 | 10-2 | 12-5 | 14-5 | 5-2 | 7-7 | 9-7 | 11-8 | 13-7 |
| | Hem-fir | #2 | 5-2 | 7-7 | 9-7 | 11-9 | 13-7 | 4-11 | 7-2 | 9-1 | 11-1 | 12-10 |
| | Hem-fir | #3 | 4-0 | 5-10 | 7-4 | 9-0 | 10-5 | 3-9 | 5-6 | 6-11 | 8-6 | 9-10 |
| | Southern pine | SS | 6-4 | 10-0 | 13-2 | 16-9 | 20-4 | 6-4 | 10-0 | 13-2 | 16-5 | 19-2 |
| | Southern pine | #1 | 6-3 | 9-3 | 11-8 | 13-10 | 16-6 | 5-11 | 8-9 | 11-0 | 13-1 | 15-7 |
| | Southern pine | #2 | 5-7 | 8-1 | 10-5 | 12-5 | 14-7 | 5-4 | 7-7 | 9-10 | 11-9 | 13-9 |
| | Southern pine | #3 | 4-3 | 6-3 | 8-0 | 9-5 | 11-2 | 4-0 | 5-11 | 7-6 | 8-10 | 10-7 |
| | Spruce-pine-fir | SS | 6-0 | 9-2 | 11-8 | 14-3 | 16-6 | 5-11 | 8-8 | 11-0 | 13-5 | 15-7 |
| | Spruce-pine-fir | #1 | 5-3 | 7-8 | 9-9 | 11-11 | 13-10 | 5-0 | 7-3 | 9-2 | 11-3 | 13-0 |
| | Spruce-pine-fir | #2 | 5-3 | 7-8 | 9-9 | 11-11 | 13-10 | 5-0 | 7-3 | 9-2 | 11-3 | 13-0 |
| Spruce-pine-fir | #3 | 4-0 | 5-10 | 7-4 | 9-0 | 10-5 | 3-9 | 5-6 | 6-11 | 8-6 | 9-10 | |

(continued)

TABLE R802.5.1(7)—continued
RAFTER SPANS FOR 70 PSF GROUND SNOW LOAD
(Ceiling not attached to rafters, L/Δ = 180)

| RAFTER SPACING (inches) | SPECIES AND GRADE | | DEAD LOAD = 10 psf | | | | | DEAD LOAD = 20 psf | | | | |
|-------------------------|-------------------|----|-----------------------------------|-----------------|-----------------|-----------------|-----------------|--------------------|-----------------|-----------------|-----------------|-----------------|
| | | | 2 x 4 | 2 x 6 | 2 x 8 | 2 x 10 | 2 x 12 | 2 x 4 | 2 x 6 | 2 x 8 | 2 x 10 | 2 x 12 |
| | | | Maximum rafter spans ^a | | | | | | | | | |
| | | | (feet - inches) | (feet - inches) | (feet - inches) | (feet - inches) | (feet - inches) | (feet - inches) | (feet - inches) | (feet - inches) | (feet - inches) | (feet - inches) |
| 24 | Douglas fir-larch | SS | 6-0 | 8-10 | 11-3 | 13-9 | 15-11 | 5-9 | 8-4 | 10-7 | 12-11 | 15-0 |
| | Douglas fir-larch | #1 | 5-0 | 7-4 | 9-4 | 11-5 | 13-2 | 4-9 | 6-11 | 8-9 | 10-9 | 12-5 |
| | Douglas fir-larch | #2 | 4-8 | 6-11 | 8-9 | 10-8 | 12-4 | 4-5 | 6-6 | 8-3 | 10-0 | 11-8 |
| | Douglas fir-larch | #3 | 3-7 | 5-2 | 6-7 | 8-1 | 9-4 | 3-4 | 4-11 | 6-3 | 7-7 | 8-10 |
| | Hem-fir | SS | 5-8 | 8-8 | 11-0 | 13-6 | 13-11 | 5-7 | 8-3 | 10-5 | 12-4 | 12-4 |
| | Hem-fir | #1 | 4-11 | 7-2 | 9-1 | 11-1 | 12-10 | 4-7 | 6-9 | 8-7 | 10-6 | 12-2 |
| | Hem-fir | #2 | 4-8 | 6-9 | 8-7 | 10-6 | 12-2 | 4-4 | 6-5 | 8-1 | 9-11 | 11-6 |
| | Hem-fir | #3 | 3-7 | 5-2 | 6-7 | 8-1 | 9-4 | 3-4 | 4-11 | 6-3 | 7-7 | 8-10 |
| | Southern pine | SS | 5-11 | 9-3 | 12-2 | 15-7 | 18-2 | 5-11 | 9-3 | 12-2 | 14-8 | 17-2 |
| | Southern pine | #1 | 5-7 | 8-3 | 10-5 | 12-5 | 14-9 | 5-3 | 7-10 | 9-10 | 11-8 | 13-11 |
| | Southern pine | #2 | 5-0 | 7-3 | 9-4 | 11-1 | 13-0 | 4-9 | 6-10 | 8-9 | 10-6 | 12-4 |
| | Southern pine | #3 | 3-9 | 5-7 | 7-1 | 8-5 | 10-0 | 3-7 | 5-3 | 6-9 | 7-11 | 9-5 |
| | Spruce-pine-fir | SS | 5-6 | 8-3 | 10-5 | 12-9 | 14-9 | 5-4 | 7-9 | 9-10 | 12-0 | 12-11 |
| | Spruce-pine-fir | #1 | 4-8 | 6-11 | 8-9 | 10-8 | 12-4 | 4-5 | 6-6 | 8-3 | 10-0 | 11-8 |
| | Spruce-pine-fir | #2 | 4-8 | 6-11 | 8-9 | 10-8 | 12-4 | 4-5 | 6-6 | 8-3 | 10-0 | 11-8 |
| | Spruce-pine-fir | #3 | 3-7 | 5-2 | 6-7 | 8-1 | 9-4 | 3-4 | 4-11 | 6-3 | 7-7 | 8-10 |

Check sources for availability of lumber in lengths greater than 20 feet.

For SI: 1 inch = 25.4 mm, 1 foot = 304.8 mm, 1 pound per square foot = 0.0479kPa.

- a. The tabulated rafter spans assume that ceiling joists are located at the bottom of the attic space or that some other method of resisting the outward push of the rafters on the bearing walls, such as rafter ties, is provided at that location. When ceiling joists or rafter ties are located higher in the attic space, the rafter spans shall be multiplied by the factors given below:

| H_C/H_R | Rafter Span Adjustment Factor |
|---------------|-------------------------------|
| 1/3 | 0.67 |
| 1/4 | 0.76 |
| 1/5 | 0.83 |
| 1/6 | 0.90 |
| 1/7.5 or less | 1.00 |

where:

H_C = Height of ceiling joists or rafter ties measured vertically above the top of the rafter support walls.

H_R = Height of roof ridge measured vertically above the top of the rafter support walls.

TABLE R802.5.1(8)
RAFTER SPANS FOR 70 PSF GROUND SNOW LOAD
(Ceiling attached to rafters, L/Δ = 240)

| RAFTER SPACING (inches) | SPECIES AND GRADE | DEAD LOAD = 10 psf | | | | | DEAD LOAD = 20 psf | | | | | |
|-------------------------|-------------------|-----------------------------------|-----------------|-----------------|-----------------|-----------------|--------------------|-----------------|-----------------|-----------------|-----------------|-------|
| | | 2 x 4 | 2 x 6 | 2 x 8 | 2 x 10 | 2 x 12 | 2 x 4 | 2 x 6 | 2 x 8 | 2 x 10 | 2 x 12 | |
| | | Maximum rafter spans ^a | | | | | | | | | | |
| | | (feet - inches) | (feet - inches) | (feet - inches) | (feet - inches) | (feet - inches) | (feet - inches) | (feet - inches) | (feet - inches) | (feet - inches) | (feet - inches) | |
| 12 | Douglas fir-larch | SS | 6-10 | 10-9 | 14-3 | 18-2 | 22-1 | 6-10 | 10-9 | 14-3 | 18-2 | 21-2 |
| | Douglas fir-larch | #1 | 6-7 | 10-5 | 13-2 | 16-1 | 18-8 | 6-7 | 9-10 | 12-5 | 15-2 | 17-7 |
| | Douglas fir-larch | #2 | 6-6 | 9-9 | 12-4 | 15-1 | 17-6 | 6-3 | 9-2 | 11-8 | 14-2 | 16-6 |
| | Douglas fir-larch | #3 | 5-0 | 7-4 | 9-4 | 11-5 | 13-2 | 4-9 | 6-11 | 8-9 | 10-9 | 12-5 |
| | Hem-fir | SS | 6-6 | 10-2 | 13-5 | 17-2 | 20-10 | 6-6 | 10-2 | 13-5 | 17-2 | 20-10 |
| | Hem-fir | #1 | 6-4 | 10-0 | 12-10 | 15-8 | 18-2 | 6-4 | 9-7 | 12-1 | 14-10 | 17-2 |
| | Hem-fir | #2 | 6-1 | 9-6 | 12-2 | 14-10 | 17-3 | 6-1 | 9-1 | 11-5 | 14-0 | 16-3 |
| | Hem-fir | #3 | 5-0 | 7-4 | 9-4 | 11-5 | 13-2 | 4-9 | 6-11 | 8-9 | 10-9 | 12-5 |
| | Southern pine | SS | 6-9 | 10-7 | 14-0 | 17-10 | 21-8 | 6-9 | 10-7 | 14-0 | 17-10 | 21-8 |
| | Southern pine | #1 | 6-7 | 10-5 | 13-8 | 17-6 | 20-11 | 6-7 | 10-5 | 13-8 | 16-6 | 19-8 |
| | Southern pine | #2 | 6-6 | 10-2 | 13-2 | 15-9 | 18-5 | 6-6 | 9-7 | 12-5 | 14-10 | 17-5 |
| | Southern pine | #3 | 5-4 | 7-11 | 10-1 | 11-11 | 14-2 | 5-1 | 7-5 | 9-6 | 11-3 | 13-4 |
| | Spruce-pine-fir | SS | 6-4 | 10-0 | 13-2 | 16-9 | 20-5 | 6-4 | 10-0 | 13-2 | 16-9 | 19-8 |
| | Spruce-pine-fir | #1 | 6-2 | 9-9 | 12-4 | 15-1 | 17-6 | 6-2 | 9-2 | 11-8 | 14-2 | 16-6 |
| | Spruce-pine-fir | #2 | 6-2 | 9-9 | 12-4 | 15-1 | 17-6 | 6-2 | 9-2 | 11-8 | 14-2 | 16-6 |
| Spruce-pine-fir | #3 | 5-0 | 7-4 | 9-4 | 11-5 | 13-2 | 4-9 | 6-11 | 8-9 | 10-9 | 12-5 | |
| 16 | Douglas fir-larch | SS | 6-3 | 9-10 | 12-11 | 16-6 | 19-6 | 6-3 | 9-10 | 12-11 | 15-10 | 18-4 |
| | Douglas fir-larch | #1 | 6-0 | 9-0 | 11-5 | 13-11 | 16-2 | 5-10 | 8-6 | 10-9 | 13-2 | 15-3 |
| | Douglas fir-larch | #2 | 5-9 | 8-5 | 10-8 | 13-1 | 15-2 | 5-5 | 7-11 | 10-1 | 12-4 | 14-3 |
| | Douglas fir-larch | #3 | 4-4 | 6-4 | 8-1 | 9-10 | 11-5 | 4-1 | 6-0 | 7-7 | 9-4 | 10-9 |
| | Hem-fir | SS | 5-11 | 9-3 | 12-2 | 15-7 | 18-11 | 5-11 | 9-3 | 12-2 | 15-7 | 18-0 |
| | Hem-fir | #1 | 5-9 | 8-9 | 11-2 | 13-7 | 15-9 | 5-8 | 8-3 | 10-6 | 12-10 | 14-10 |
| | Hem-fir | #2 | 5-6 | 8-4 | 10-6 | 12-10 | 14-11 | 5-4 | 7-10 | 9-11 | 12-1 | 14-1 |
| | Hem-fir | #3 | 4-4 | 6-4 | 8-1 | 9-10 | 11-5 | 4-1 | 6-0 | 7-7 | 9-4 | 10-9 |
| | Southern pine | SS | 6-1 | 9-7 | 12-8 | 16-2 | 19-8 | 6-1 | 9-7 | 12-8 | 16-2 | 19-8 |
| | Southern pine | #1 | 6-0 | 9-5 | 12-5 | 15-2 | 18-1 | 6-0 | 9-5 | 12-0 | 14-4 | 17-1 |
| | Southern pine | #2 | 5-11 | 8-10 | 11-5 | 13-7 | 16-0 | 5-10 | 8-4 | 10-9 | 12-10 | 15-1 |
| | Southern pine | #3 | 4-8 | 6-10 | 8-9 | 10-4 | 12-3 | 4-4 | 6-5 | 8-3 | 9-9 | 11-7 |
| | Spruce-pine-fir | SS | 5-9 | 9-1 | 11-11 | 15-3 | 18-1 | 5-9 | 9-1 | 11-11 | 14-8 | 17-1 |
| | Spruce-pine-fir | #1 | 5-8 | 8-5 | 10-8 | 13-1 | 15-2 | 5-5 | 7-11 | 10-1 | 12-4 | 14-3 |
| | Spruce-pine-fir | #2 | 5-8 | 8-5 | 10-8 | 13-1 | 15-2 | 5-5 | 7-11 | 10-1 | 12-4 | 14-3 |
| Spruce-pine-fir | #3 | 4-4 | 6-4 | 8-1 | 9-10 | 11-5 | 4-1 | 6-0 | 7-7 | 9-4 | 10-9 | |
| 19.2 | Douglas fir-larch | SS | 5-10 | 9-3 | 12-2 | 15-4 | 17-9 | 5-10 | 9-3 | 11-10 | 14-5 | 16-9 |
| | Douglas fir-larch | #1 | 5-7 | 8-3 | 10-5 | 12-9 | 14-9 | 5-4 | 7-9 | 9-10 | 12-0 | 13-11 |
| | Douglas fir-larch | #2 | 5-3 | 7-8 | 9-9 | 11-11 | 13-10 | 5-0 | 7-3 | 9-2 | 11-3 | 13-0 |
| | Douglas fir-larch | #3 | 4-0 | 5-10 | 7-4 | 9-0 | 10-5 | 3-9 | 5-6 | 6-11 | 8-6 | 9-10 |
| | Hem-fir | SS | 5-6 | 8-8 | 11-6 | 14-8 | 17-4 | 5-6 | 8-8 | 11-6 | 14-2 | 15-5 |
| | Hem-fir | #1 | 5-5 | 8-0 | 10-2 | 12-5 | 14-5 | 5-2 | 7-7 | 9-7 | 11-8 | 13-7 |
| | Hem-fir | #2 | 5-2 | 7-7 | 9-7 | 11-9 | 13-7 | 4-11 | 7-2 | 9-1 | 11-1 | 12-10 |
| | Hem-fir | #3 | 4-0 | 5-10 | 7-4 | 9-0 | 10-5 | 3-9 | 5-6 | 6-11 | 8-6 | 9-10 |
| | Southern pine | SS | 5-9 | 9-1 | 11-11 | 15-3 | 18-6 | 5-9 | 9-1 | 11-11 | 15-3 | 18-6 |
| | Southern pine | #1 | 5-8 | 8-11 | 11-8 | 13-10 | 16-6 | 5-8 | 8-9 | 11-0 | 13-1 | 15-7 |
| | Southern pine | #2 | 5-6 | 8-1 | 10-5 | 12-5 | 14-7 | 5-4 | 7-7 | 9-10 | 11-9 | 13-9 |
| | Southern pine | #3 | 4-3 | 6-3 | 8-0 | 9-5 | 11-2 | 4-0 | 5-11 | 7-6 | 8-10 | 10-7 |
| | Spruce-pine-fir | SS | 5-5 | 8-6 | 11-3 | 14-3 | 16-6 | 5-5 | 8-6 | 11-0 | 13-5 | 15-7 |
| | Spruce-pine-fir | #1 | 5-3 | 7-8 | 9-9 | 11-11 | 13-10 | 5-0 | 7-3 | 9-2 | 11-3 | 13-0 |
| | Spruce-pine-fir | #2 | 5-3 | 7-8 | 9-9 | 11-11 | 13-10 | 5-0 | 7-3 | 9-2 | 11-3 | 13-0 |
| Spruce-pine-fir | #3 | 4-0 | 5-10 | 7-4 | 9-0 | 10-5 | 3-9 | 5-6 | 6-11 | 8-6 | 9-10 | |

(continued)

TABLE R802.5.1(8)—continued
RAFTER SPANS FOR 70 PSF GROUND SNOW LOAD^a
(Ceiling attached to rafters, L/Δ = 240)

| RAFTER SPACING (inches) | SPECIES AND GRADE | | DEAD LOAD = 10 psf | | | | | DEAD LOAD = 20 psf | | | | |
|-------------------------|-------------------|----|-----------------------------------|-----------------|-----------------|-----------------|-----------------|--------------------|-----------------|-----------------|-----------------|-----------------|
| | | | 2 x 4 | 2 x 6 | 2 x 8 | 2 x 10 | 2 x 12 | 2 x 4 | 2 x 6 | 2 x 8 | 2 x 10 | 2 x 12 |
| | | | Maximum rafter spans ^a | | | | | | | | | |
| | | | (feet - inches) | (feet - inches) | (feet - inches) | (feet - inches) | (feet - inches) | (feet - inches) | (feet - inches) | (feet - inches) | (feet - inches) | (feet - inches) |
| 24 | Douglas fir-larch | SS | 5-5 | 8-7 | 11-3 | 13-9 | 15-11 | 5-5 | 8-4 | 10-7 | 12-11 | 15-0 |
| | Douglas fir-larch | #1 | 5-0 | 7-4 | 9-4 | 11-5 | 13-2 | 4-9 | 6-11 | 8-9 | 10-9 | 12-5 |
| | Douglas fir-larch | #2 | 4-8 | 6-11 | 8-9 | 10-8 | 12-4 | 4-5 | 6-6 | 8-3 | 10-0 | 11-8 |
| | Douglas fir-larch | #3 | 3-7 | 5-2 | 6-7 | 8-1 | 9-4 | 3-4 | 4-11 | 6-3 | 7-7 | 8-10 |
| | Hem-fir | SS | 5-2 | 8-1 | 10-8 | 13-6 | 13-11 | 5-2 | 8-1 | 10-5 | 12-4 | 12-4 |
| | Hem-fir | #1 | 4-11 | 7-2 | 9-1 | 11-1 | 12-10 | 4-7 | 6-9 | 8-7 | 10-6 | 12-2 |
| | Hem-fir | #2 | 4-8 | 6-9 | 8-7 | 10-6 | 12-2 | 4-4 | 6-5 | 8-1 | 9-11 | 11-6 |
| | Hem-fir | #3 | 3-7 | 5-2 | 6-7 | 8-1 | 9-4 | 3-4 | 4-11 | 6-3 | 7-7 | 8-10 |
| | Southern pine | SS | 5-4 | 8-5 | 11-1 | 14-2 | 17-2 | 5-4 | 8-5 | 11-1 | 14-2 | 17-2 |
| | Southern pine | #1 | 5-3 | 8-3 | 10-5 | 12-5 | 14-9 | 5-3 | 7-10 | 9-10 | 11-8 | 13-11 |
| | Southern pine | #2 | 5-0 | 7-3 | 9-4 | 11-1 | 13-0 | 4-9 | 6-10 | 8-9 | 10-6 | 12-4 |
| | Southern pine | #3 | 3-9 | 5-7 | 7-1 | 8-5 | 10-0 | 3-7 | 5-3 | 6-9 | 7-11 | 9-5 |
| | Spruce-pine-fir | SS | 5-0 | 7-11 | 10-5 | 12-9 | 14-9 | 5-0 | 7-9 | 9-10 | 12-0 | 12-11 |
| | Spruce-pine-fir | #1 | 4-8 | 6-11 | 8-9 | 10-8 | 12-4 | 4-5 | 6-6 | 8-3 | 10-0 | 11-8 |
| | Spruce-pine-fir | #2 | 4-8 | 6-11 | 8-9 | 10-8 | 12-4 | 4-5 | 6-6 | 8-3 | 10-0 | 11-8 |
| | Spruce-pine-fir | #3 | 3-7 | 5-2 | 6-7 | 8-1 | 9-4 | 3-4 | 4-11 | 6-3 | 7-7 | 8-10 |

Check sources for availability of lumber in lengths greater than 20 feet.

For SI: 1 inch = 25.4 mm, 1 foot = 304.8 mm, 1 pound per square foot = 0.0479kPa.

- a. The tabulated rafter spans assume that ceiling joists are located at the bottom of the attic space or that some other method of resisting the outward push of the rafters on the bearing walls, such as rafter ties, is provided at that location. When ceiling joists or rafter ties are located higher in the attic space, the rafter spans shall be multiplied by the factors given below:

| H_C/H_R | Rafter Span Adjustment Factor |
|---------------|-------------------------------|
| 1/3 | 0.67 |
| 1/4 | 0.76 |
| 1/5 | 0.83 |
| 1/6 | 0.90 |
| 1/7.5 or less | 1.00 |

where:

H_C = Height of ceiling joists or rafter ties measured vertically above the top of the rafter support walls.

H_R = Height of roof ridge measured vertically above the top of the rafter support walls.

TABLE R802.5.1(9)
RAFTER/CEILING JOIST HEEL JOINT CONNECTIONS^{a, b, c, d, e, f, g}

| RAFTER SLOPE | RAFTER SPACING (inches) | GROUND SNOW LOAD (psf) | | | | | | | | | | | |
|--|-------------------------|------------------------|----|----|----|----|----|----|----|----|----|----|----|
| | | 30 | | | | 50 | | | | 70 | | | |
| | | Roof span (feet) | | | | | | | | | | | |
| | | 12 | 20 | 28 | 36 | 12 | 20 | 28 | 36 | 12 | 20 | 28 | 36 |
| Required number of 16d common nails ^{a,b} per heel joint splices ^{c,d,e,f} | | | | | | | | | | | | | |
| 3:12 | 12 | 4 | 6 | 8 | 11 | 5 | 8 | 12 | 15 | 6 | 11 | 15 | 20 |
| | 16 | 5 | 8 | 11 | 14 | 6 | 11 | 15 | 20 | 8 | 14 | 20 | 26 |
| | 24 | 7 | 11 | 16 | 21 | 9 | 16 | 23 | 30 | 12 | 21 | 30 | 39 |
| 4:12 | 12 | 3 | 5 | 6 | 8 | 4 | 6 | 9 | 11 | 5 | 8 | 12 | 15 |
| | 16 | 4 | 6 | 8 | 11 | 5 | 8 | 12 | 15 | 6 | 11 | 15 | 20 |
| | 24 | 5 | 9 | 12 | 16 | 7 | 12 | 17 | 22 | 9 | 16 | 23 | 29 |
| 5:12 | 12 | 3 | 4 | 5 | 7 | 3 | 5 | 7 | 9 | 4 | 7 | 9 | 12 |
| | 16 | 3 | 5 | 7 | 9 | 4 | 7 | 9 | 12 | 5 | 9 | 12 | 16 |
| | 24 | 4 | 7 | 10 | 13 | 6 | 10 | 14 | 18 | 7 | 13 | 18 | 23 |
| 7:12 | 12 | 3 | 3 | 4 | 5 | 3 | 4 | 5 | 7 | 3 | 5 | 7 | 9 |
| | 16 | 3 | 4 | 5 | 6 | 3 | 5 | 7 | 9 | 4 | 6 | 9 | 11 |
| | 24 | 3 | 5 | 7 | 9 | 4 | 7 | 10 | 13 | 5 | 9 | 13 | 17 |
| 9:12 | 12 | 3 | 3 | 3 | 4 | 3 | 3 | 4 | 5 | 3 | 4 | 5 | 7 |
| | 16 | 3 | 3 | 4 | 5 | 3 | 4 | 5 | 7 | 3 | 5 | 7 | 9 |
| | 24 | 3 | 4 | 6 | 7 | 3 | 6 | 8 | 10 | 4 | 7 | 10 | 13 |
| 12:12 | 12 | 3 | 3 | 3 | 3 | 3 | 3 | 3 | 4 | 3 | 3 | 4 | 5 |
| | 16 | 3 | 3 | 3 | 4 | 3 | 3 | 4 | 5 | 3 | 4 | 5 | 7 |
| | 24 | 3 | 3 | 4 | 6 | 3 | 4 | 6 | 8 | 3 | 6 | 8 | 10 |

For SI: 1 inch = 25.4 mm, 1 foot = 304.8 mm, 1 pound per square foot = 0.0479 kPa.

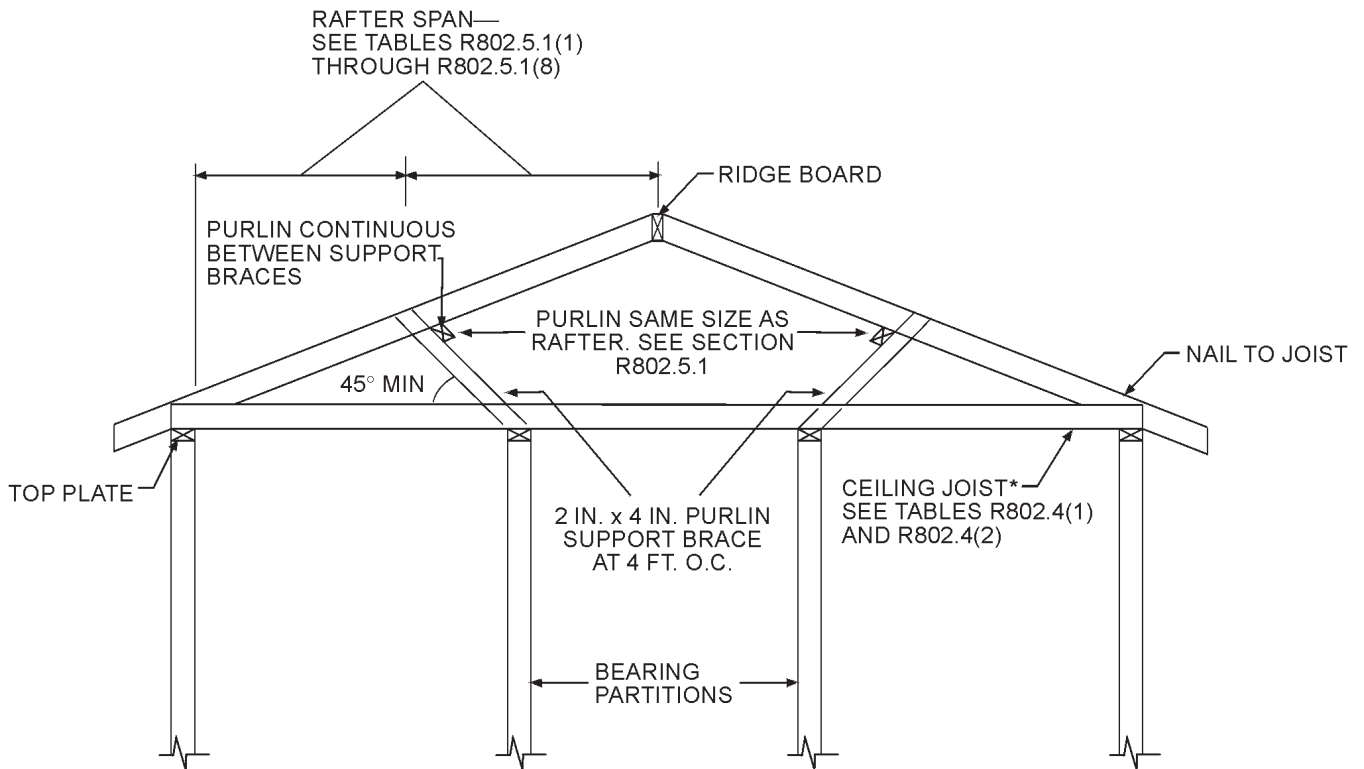
- a. 40d box nails shall be permitted to be substituted for 16d common nails.
- b. Nailing requirements shall be permitted to be reduced 25 percent if nails are clinched.
- c. Heel joint connections are not required when the ridge is supported by a load-bearing wall, header or ridge beam.
- d. When intermediate support of the rafter is provided by vertical struts or purlins to a loadbearing wall, the tabulated heel joint connection requirements shall be permitted to be reduced proportionally to the reduction in span.
- e. Equivalent nailing patterns are required for ceiling joist to ceiling joist lap splices.
- f. When rafter ties are substituted for ceiling joists, the heel joint connection requirement shall be taken as the tabulated heel joint connection requirement for two-thirds of the actual rafter-slope.
- g. Tabulated heel joint connection requirements assume that ceiling joists or rafter ties are located at the bottom of the attic space. When ceiling joists or rafter ties are located higher in the attic, heel joint connection requirements shall be increased by the following factors:

| H_C/H_R | Heel Joint Connection Adjustment Factor |
|--------------|---|
| 1/3 | 1.5 |
| 1/4 | 1.33 |
| 1/5 | 1.25 |
| 1/6 | 1.2 |
| 1/10 or less | 1.11 |

where:

H_C = Height of ceiling joists or rafter ties measured vertically above the top of the rafter support walls.

H_R = Height of roof ridge measured vertically above the top of the rafter support walls.



For SI: 1 inch = 25.4 mm, 1 foot = 304.8 mm, 1 degree = 0.018 rad.

NOTE: Where ceiling joints run perpendicular to the rafters, rafter ties shall be nailed to each rafter near the top of the ceiling joist.

**FIGURE R802.5.1
BRACED RAFTER CONSTRUCTION**

R802.10.2.1 Applicability limits. The provisions of this section shall control the design of truss roof framing when snow controls for buildings not greater than 60 feet (18 288 mm) in length perpendicular to the joist, rafter or truss span, not greater than 36 feet (10 973 mm) in width parallel to the joist span or truss, not greater than two stories in height with each story not greater than 10 feet (3048 mm) high, and roof slopes not smaller than 3:12 (25-percent slope) or greater than 12:12 (100-percent slope). Truss roof framing constructed in accordance with the provisions of this section shall be limited to sites subjected to a maximum design wind speed of 110 miles per hour (49 m/s), Exposure A, B or C, and a maximum ground snow load of 70 psf (3352 Pa). Roof snow load is to be computed as: $0.7 p_g$.

R802.10.3 Bracing. Trusses shall be braced to prevent rotation and provide lateral stability in accordance with the requirements specified in the construction documents for the building and on the individual truss design drawings. In the absence of specific bracing requirements, trusses shall be braced in accordance with the Building Component Safety Information (BCSI 1-03) Guide to Good Practice for Handling, Installing & Bracing of Metal Plate Connected Wood Trusses.

R802.10.4 Alterations to trusses. Truss members shall not be cut, notched, drilled, spliced or otherwise altered in any

way without the approval of a registered design professional. Alterations resulting in the addition of load (e.g., HVAC equipment, water heater) that exceeds the design load for the truss shall not be permitted without verification that the truss is capable of supporting such additional loading.

R802.10.5 Truss to wall connection. Trusses shall be connected to wall plates by the use of approved connectors having a resistance to uplift of not less than 175 pounds (779 N) and shall be installed in accordance with the manufacturer's specifications. For roof assemblies subject to wind uplift pressures of 20 pounds per square foot (960 Pa) or greater, as established in Table R301.2(2), adjusted for height and exposure per Table R301.2(3), see section R802.11.

R802.11 Roof tie-down.

R802.11.1 Uplift resistance. Roof assemblies which are subject to wind uplift pressures of 20 pounds per square foot (960 Pa) or greater shall have roof rafters or trusses attached to their supporting wall assemblies by connections capable of providing the resistance required in Table R802.11. Wind uplift pressures shall be determined using an effective wind area of 100 square feet (9.3 m²) and Zone 1 in Table R301.2(2), as adjusted for height and exposure per Table R301.2(3).

A continuous load path shall be designed to transmit the uplift forces from the rafter or truss ties to the foundation.

TABLE R802.11
REQUIRED STRENGTH OF TRUSS OR RAFTER CONNECTIONS TO RESIST WIND UPLIFT FORCES^{a, b, c, e, f}
(Pounds per connection)

| BASIC WIND SPEED (mph) (3-second gust) | ROOF SPAN (feet) | | | | | | | OVERHANGS ^d (pounds/foot) |
|---|------------------|------|------|------|------|------|------|---|
| | 12 | 20 | 24 | 28 | 32 | 36 | 40 | |
| 85 | -72 | -120 | -145 | -169 | -193 | -217 | -241 | -38.55 |
| 90 | -91 | -151 | -181 | -212 | -242 | -272 | -302 | -43.22 |
| 100 | -131 | -218 | -262 | -305 | -349 | -393 | -436 | -53.36 |
| 110 | -175 | -292 | -351 | -409 | -467 | -526 | -584 | -64.56 |

For SI: 1 inch = 25.4 mm, 1 foot = 305 mm, 1 mph = 0.447 m/s, 1 pound/foot = 14.5939 N/m, 1 pound = 0.454 kg.

- a. The uplift connection requirements are based on a 30 foot mean roof height located in Exposure B. For Exposures C and D and for other mean roof heights, multiply the above loads by the Adjustment Coefficients in Table R301.2(3).
- b. The uplift connection requirements are based on the framing being spaced 24 inches on center. Multiply by 0.67 for framing spaced 16 inches on center and multiply by 0.5 for framing spaced 12 inches on center.
- c. The uplift connection requirements include an allowance for 10 pounds of dead load.
- d. The uplift connection requirements do not account for the effects of overhangs. The magnitude of the above loads shall be increased by adding the overhang loads found in the table. The overhang loads are also based on framing spaced 24 inches on center. The overhang loads given shall be multiplied by the overhang projection and added to the roof uplift value in the table.
- e. The uplift connection requirements are based on wind loading on end zones as defined in Figure 6-2 of ASCE 7. Connection loads for connections located a distance of 20% of the least horizontal dimension of the building from the corner of the building are permitted to be reduced by multiplying the table connection value by 0.7 and multiplying the overhang load by 0.8.
- f. For wall-to-wall and wall-to-foundation connections, the capacity of the uplift connector is permitted to be reduced by 100 pounds for each full wall above. (For example, if a 600-pound rated connector is used on the roof framing, a 500-pound rated connector is permitted at the next floor level down).

SECTION R803
ROOF SHEATHING

R803.1 Lumber sheathing. Allowable spans for lumber used as roof sheathing shall conform to Table R803.1. Spaced lumber sheathing for wood shingle and shake roofing shall conform to the requirements of Sections R905.7 and R905.8. Spaced lumber sheathing is not allowed in Seismic Design Category D₂.

TABLE R803.1
MINIMUM THICKNESS OF LUMBER ROOF SHEATHING

| RAFTER OR BEAM SPACING (inches) | MINIMUM NET THICKNESS (inches) |
|------------------------------------|-----------------------------------|
| 24 | 5/8 |
| 48 ^a | 1 1/2 T & G |
| 60 ^b | |
| 72 ^c | |

For SI: 1 inch = 25.4 mm.

- a. Minimum 270 *F_b*, 340,000 *E*.
- b. Minimum 420 *F_b*, 660,000 *E*.
- c. Minimum 600 *F_b*, 1,150,000 *E*.

R803.2 Wood structural panel sheathing.

R803.2.1 Identification and grade. Wood structural panels shall conform to DOC PS 1, DOC PS 2 or, when manufactured in Canada, CSA 0437, and shall be identified by a grade mark or certificate of inspection issued by an approved agency. Wood structural panels shall comply with the grades specified in Table R503.2.1.1(1).

R803.2.1.1 Exposure durability. All wood structural panels, when designed to be permanently exposed in outdoor applications, shall be of an exterior exposure durability. Wood structural panel roof sheathing exposed to the underside may be of interior type bonded with exterior glue, identified as Exposure 1.

R803.2.1.2 Fire-retardant-treated plywood. The allowable unit stresses for fire-retardant-treated plywood, includ-

ing fastener values, shall be developed from an approved method of investigation that considers the effects of anticipated temperature and humidity to which the fire-retardant-treated plywood will be subjected, the type of treatment and redrying process. The fire-retardant-treated plywood shall be graded by an approved agency.

R803.2.2 Allowable spans. The maximum allowable spans for wood structural panel roof sheathing shall not exceed the values set forth in Table R503.2.1.1(1), or APA E30.

R803.2.3 Installation. Wood structural panel used as roof sheathing shall be installed with joints staggered or not staggered in accordance with Table R602.3(1), or APA E30 for wood roof framing or with Table R804.3 for steel roof framing.

SECTION R804
STEEL ROOF FRAMING

R804.1 General. Elements shall be straight and free of any defects that would significantly affect their structural performance. Cold-formed steel roof framing members shall comply with the requirements of this section.

R804.1.1 Applicability limits. The provisions of this section shall control the construction of steel roof framing for buildings not greater than 60 feet (18 288 mm) perpendicular to the joist, rafter or truss span, not greater than 40 feet (12 192 mm) in width parallel to the joist span or truss, not greater than two stories in height and roof slopes not smaller than 3:12 (25-percent slope) or greater than 12:12 (100 percent slope). Steel roof framing constructed in accordance with the provisions of this section shall be limited to sites subjected to a maximum design wind speed of 110 miles per hour (49 m/s), Exposure A, B, or C, and a maximum ground snow load of 70 pounds per square foot (3350 Pa).

R804.1.2 In-line framing. Steel roof framing constructed in accordance with Section R804 shall be located directly in line with load-bearing studs below with a maximum toler-

ance of $\frac{3}{4}$ inch (19 mm) between the centerline of the stud and the roof joist/rafter.

R804.1.3 Roof trusses. The design, quality assurance, installation and testing of cold-formed steel trusses shall be in accordance with the AISI Standard for Cold-formed Steel Framing-Truss Design (COFS/Truss). Truss members shall not be notched, cut or altered in any manner without an approved design.

R804.2 Structural framing. Load-bearing steel roof framing members shall comply with Figure R804.2(1) and with the dimensional and minimum thickness requirements specified in Tables R804.2(1) and R804.2(2). Tracks shall comply with Figure R804.2(2) and shall have a minimum flange width of $1\frac{1}{4}$ inches (32 mm). The maximum inside bend radius for load-bearing members shall be the greater of $\frac{3}{32}$ inch (2.4 mm) or twice the uncoated steel thickness. Holes in roof framing members shall comply with all of the following conditions:

1. Holes shall conform to Figure R804.2(3);
2. Holes shall be permitted only along the centerline of the web of the framing member;
3. Holes shall have a center-to-center spacing of not less than 24 inches (610 mm);
4. Holes shall have a width not greater than 0.5 times the member depth, or $2\frac{1}{2}$ inches (64 mm);
5. Holes shall have a length not exceeding $4\frac{1}{2}$ inches (114 mm); and
6. Holes shall have a minimum distance between the edge of the bearing surface and the edge of the hole of not less than 10 inches (254 mm).

Framing members with web holes not conforming to these requirements shall be patched in accordance with Section R804.3.6 or designed in accordance with accepted engineering practices.

R804.2.1 Material. Load-bearing steel framing members shall be cold-formed to shape from structural quality sheet steel complying with the requirements of one of the following:

1. ASTM A 653: Grades 33, 37, 40 and 50 (Class 1 and 3).
2. ASTM A 792: Grades 33, 37, 40 and 50A.
3. ASTM A 875: Grades 33, 37, 40 and 50 (Class 1 and 3).
4. ASTM A 1003: Grades 33, 37, 40 and 50.

R804.2.2 Identification. Load-bearing steel framing members shall have a legible label, stencil, stamp or embossment with the following information as a minimum:

1. Manufacturer’s identification.
2. Minimum uncoated steel thickness in inches (mm).
3. Minimum coating designation.
4. Minimum yield strength, in kips per square inch (ksi).

R804.2.3 Corrosion protection. Load-bearing steel framing shall have a metallic coating complying with one of the following:

1. A minimum of G 60 in accordance with ASTM A 653.
2. A minimum of AZ 50 in accordance with ASTM A 792.
3. A minimum of GF 60 in accordance with ASTM A 875.

**TABLE R804.2(1)
LOAD-BEARING COLD-FORMED STEEL MEMBER SIZES**

| NOMINAL MEMBER SIZE MEMBER DESIGNATION ^a | WEB DEPTH (inches) | MINIMUM FLANGE WIDTH (inches) | MAXIMUM FLANGE WIDTH (inches) | MINIMUM LIP SIZE (inches) |
|--|-----------------------|----------------------------------|----------------------------------|------------------------------|
| 350S162-t | 3.5 | 1.625 | 2 | 0.5 |
| 550S162-t | 5.5 | 1.625 | 2 | 0.5 |
| 800S162-t | 8 | 1.625 | 2 | 0.5 |
| 1000S162-t | 10 | 1.625 | 2 | 0.5 |
| 1200S162-t | 12 | 1.625 | 2 | 0.5 |

For SI: 1 inch = 25.4 mm.

a. The member designation is defined by the first number representing the member depth in hundredths of an inch, the letter “s” representing a stud or joist member, the second number representing the flange width in hundredths of an inch, and the letter “t” shall be a number representing the minimum base metal thickness in mils [see Table R804.2(2)].

**TABLE R804.2(2)
MINIMUM THICKNESS OF COLD-FORMED STEEL ROOF FRAMING MEMBERS**

| DESIGNATION (mils) | MINIMUM UNCOATED THICKNESS (inches) | REFERENCED GAGE NUMBER |
|--------------------|-------------------------------------|------------------------|
| 33 | 0.033 | 20 |
| 43 | 0.043 | 18 |
| 54 | 0.054 | 16 |
| 68 | 0.068 | 14 |

For SI: 1 inch = 25.4 mm, 1 mil = 0.0254 mm.

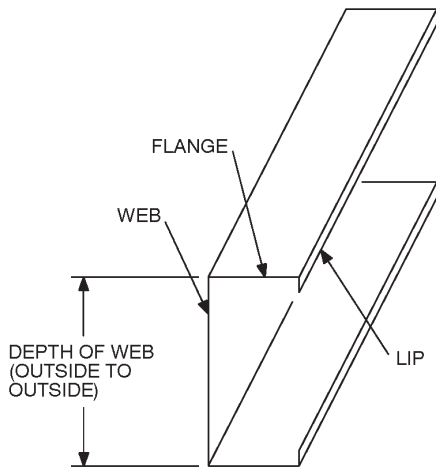


FIGURE R804.2(1)
C-SECTION

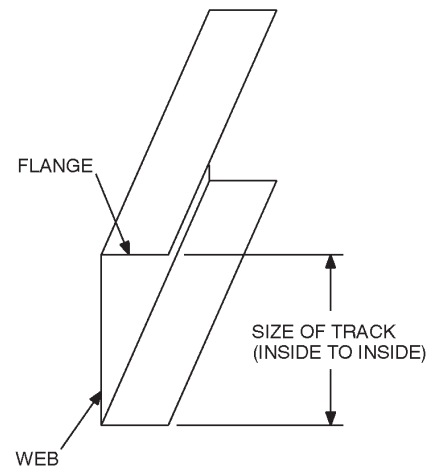


FIGURE R804.2(2)
TRACK SECTION

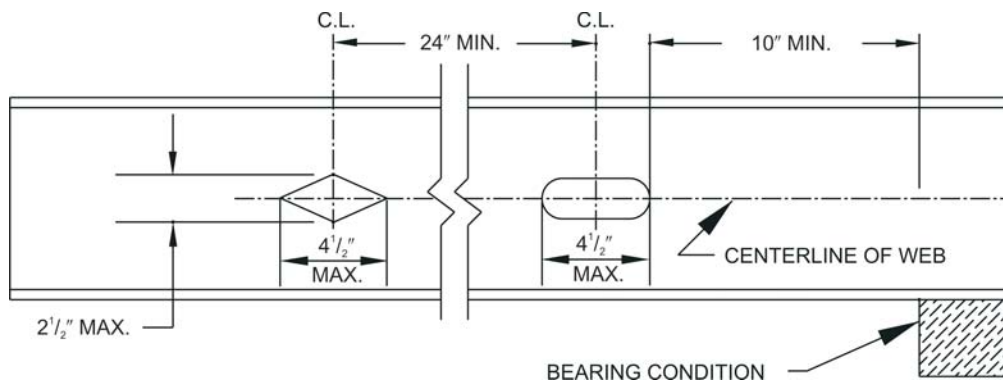


FIGURE R804.2(3)
WEB HOLES

For SI: 1 inch = 25.4 mm.

R804.2.4 Fastening requirements. Screws for steel-to-steel connections shall be installed with a minimum edge distance and center-to-center spacing of $\frac{1}{2}$ inch (13 mm), shall be self-drilling tapping, and shall conform to SAE J78. Structural sheathing shall be attached to roof rafters with minimum No. 8 self-drilling tapping screws that conform to SAE J78. Screws for attaching structural sheathing to steel roof framing shall have a minimum head diameter of 0.292 inch (7.4 mm) with countersunk heads and shall be installed with a minimum edge distance of $\frac{3}{8}$ inch (10 mm). Gypsum board ceilings shall be attached to steel joists with minimum No. 6 screws conforming to ASTM C 954 and shall be installed in accordance with Section R805. For all connections, screws shall extend through the steel a minimum of three exposed threads. All self-drilling tapping screws conforming to SAE J78 shall have a minimum Type II coating in accordance with ASTM B 633.

Where No. 8 screws are specified in a steel-to-steel connection, reduction of the required number of screws in the connection is permitted in accordance with the reduction factors in Table R804.2.4 when larger screws are used or when one of the sheets of steel being connected is thicker than 33 mils (0.84 mm). When applying the reduction factor, the resulting number of screws shall be rounded up.

TABLE R804.2.4
SCREW SUBSTITUTION FACTOR

| SCREW SIZE | THINNEST CONNECTED STEEL SHEET (mils) | |
|------------|---------------------------------------|------|
| | 33 | 43 |
| #8 | 1.0 | 0.67 |
| #10 | 0.93 | 0.62 |
| #12 | 0.86 | 0.56 |

For SI: 1 mil = 0.0254 mm.

R804.3 Roof construction. Steel roof systems constructed in accordance with the provisions of this section shall consist of both ceiling joists and rafters in accordance with Figure R804.3 and fastened in accordance with Table R804.3.

R804.3.1 Allowable ceiling joist spans. The clear span of cold-formed steel ceiling joists shall not exceed the limits set forth in Tables R804.3.1(1) through R804.3.1(8). Ceiling joists shall have a minimum bearing length of 1.5 inches (38 mm) and shall be connected to rafters (heel joint) in accordance with Figure R804.3.1(1) and Table R804.3.1. When

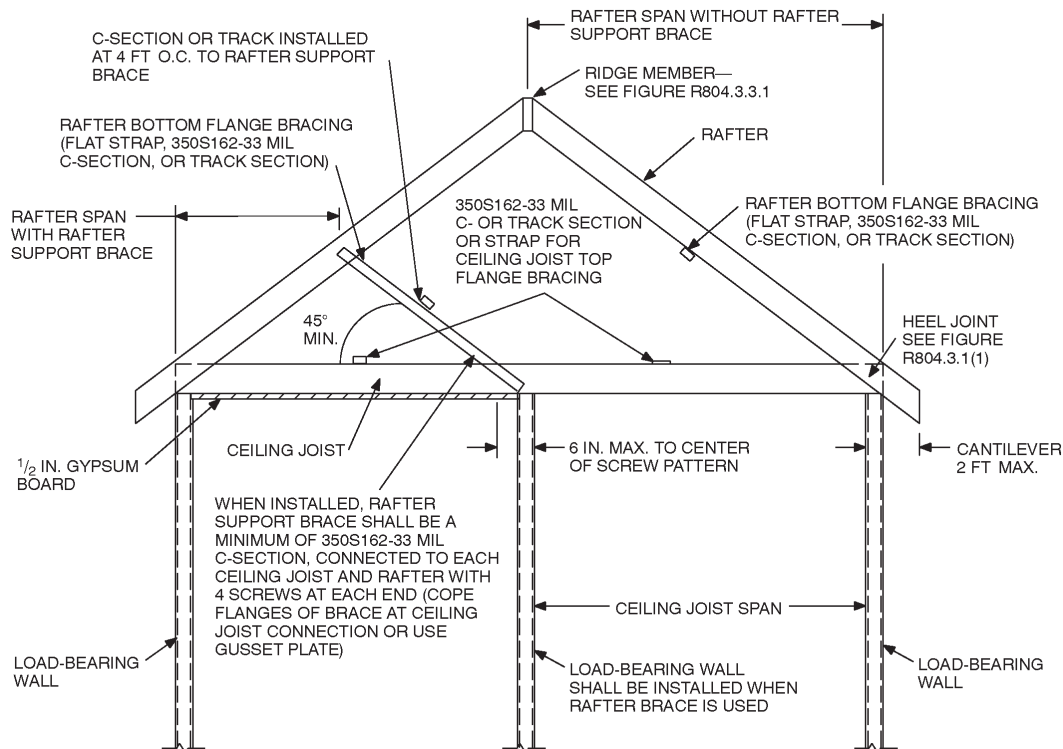
continuous joists are framed across interior bearing supports, the interior bearing supports shall be located within 24 inches (610 mm) of midspan of the ceiling joist, and the individual spans shall not exceed the applicable spans in Tables R804.3.1(2), R804.3.1(4), R804.3.1(6), R804.3.1(8). Where required in Tables R804.3.1(1) through R804.3.1(8), bearing stiffeners shall be installed at each bearing location in accordance with Section R804.3.8 and Figure R804.3.8. When the attic is to be used as an occupied space, the ceiling joists shall be designed in accordance with Section R505.

TABLE R804.3
ROOF FRAMING FASTENING SCHEDULE^{a,b}

| DESCRIPTION OF BUILDING ELEMENTS | NUMBER AND SIZE OF FASTENERS | SPACING OF FASTENERS |
|--|---|---|
| Ceiling joist to top track of load-bearing wall | 2 No. 10 screws | Each joist |
| Roof sheathing (oriented strand board or plywood) to rafters | No. 8 screws | 6" o.c. on edges and 12" o.c. at interior supports. 6" o.c. at gable end truss |
| Truss to bearing wall ^a | 2 No. 10 screws | Each truss |
| Gable end truss to endwall top track | No. 10 screws | 12" o.c. |
| Rafter to ceiling joist | Minimum No. 10 screws, per Table R804.3.1 | Evenly spaced, not less than 1/2" from all edges. |

For SI: 1 inch = 25.4 mm, 1 foot = 304.8 mm, 1 pound per square foot = 0.0479kPa, 1 mil = 0.0254 mm.

- a. Screws shall be applied through the flanges of the truss or ceiling joist or a 54 mil clip angle shall be used with two No. 10 screws in each leg. See Section R804.4 for additional requirements to resist uplift forces.
- b. Spacing of fasteners on roof sheathing panel edges applies to panel edges supported by framing members and at all roof plane perimeters. Blocking of roof sheathing panel edges perpendicular to the framing members shall not be required except at the intersection of adjacent roof planes. Roof perimeter shall be supported by framing members or cold-formed blocking of the same depth and gage as the floor members.



For SI: 1 inch = 25.4 mm, 1 foot = 304.8 mm, 1 mil = 0.0254 mm.

FIGURE R804.3
STEEL ROOF CONSTRUCTION

TABLE R804.3.1(1)
CEILING JOIST SPANS
SINGLE SPANS WITH BEARING STIFFENERS
10 lb per sq ft LIVE LOAD (NO ATTIC STORAGE)^{a, b, c} 33 ksi STEEL

| MEMBER DESIGNATION | ALLOWABLE SPAN (feet-inches) | | | | | |
|--------------------|---|---------|------------------|---------|---------------------|---------|
| | Lateral Support of Top (Compression) Flange | | | | | |
| | Unbraced | | Mid-Span Bracing | | Third-Point Bracing | |
| | Ceiling Joist Spacing (inches) | | | | | |
| | 16 | 24 | 16 | 24 | 16 | 24 |
| 350S162-33 | 9'-5" | 8'-6" | 12'-2" | 10'-4" | 12'-2" | 10'-7" |
| 350S162-43 | 10'-3" | 9'-2" | 12'-10" | 11'-2" | 12'-10" | 11'-2" |
| 350S162-54 | 11'-1" | 9'-11" | 13'-9" | 12'-0" | 13'-9" | 12'-0" |
| 350S162-68 | 12'-1" | 10'-9" | 14'-8" | 12'-10" | 14'-8" | 12'-10" |
| 350S162-97 | 14'-4" | 12'-7" | 16'-4" | 14'-3" | 16'-4" | 14'-3" |
| 550S162-33 | 10'-7" | 9'-6" | 14'-10" | 12'-10" | 15'-11" | 13'-4" |
| 550S162-43 | 11'-8" | 10'-6" | 16'-4" | 14'-3" | 17'-10" | 15'-3" |
| 550S162-54 | 12'-6" | 11'-2" | 17'-7" | 15'-7" | 19'-5" | 16'-10" |
| 550S162-68 | 13'-6" | 12'-1" | 19'-2" | 17'-1" | 21'-0" | 18'-4" |
| 550S162-97 | 15'-9" | 13'-11" | 21'-8" | 19'-3" | 23'-5" | 20'-5" |
| 800S162-33 | 12'-2" | 10'-11" | 17'-8" | 15'-10" | 19'-10" | 17'-1" |
| 800S162-43 | 13'-0" | 11'-9" | 18'-10" | 17'-0" | 21'-6" | 19'-1" |
| 800S162-54 | 13'-10" | 12'-5" | 20'-0" | 18'-0" | 22'-9" | 20'-4" |
| 800S162-68 | 14'-11" | 13'-4" | 21'-3" | 19'-1" | 24'-1" | 21'-8" |
| 800S162-97 | 17'-1" | 15'-2" | 23'-10" | 21'-3" | 26'-7" | 23'-10" |
| 1000S162-43 | 13'-11" | 12'-6" | 20'-2" | 18'-3" | 23'-1" | 20'-9" |
| 1000S162-54 | 14'-9" | 13'-3" | 21'-4" | 19'-3" | 24'-4" | 22'-0" |
| 1000S162-68 | 15'-10" | 14'-2" | 22'-8" | 20'-5" | 25'-9" | 23'-2" |
| 1000S162-97 | 18'-0" | 16'-0" | 25'-3" | 22'-7" | 28'-3" | 25'-4" |
| 1200S162-43 | 14'-8" | 13'-3" | 21'-4" | 19'-3" | 24'-5" | 21'-8" |
| 1200S162-54 | 15'-7" | 14'-0" | 22'-6" | 20'-4" | 25'-9" | 23'-2" |
| 1200S162-68 | 16'-8" | 14'-11" | 23'-11" | 21'-6" | 27'-2" | 24'-6" |
| 1000S162-97 | 18'-9" | 16'-9" | 26'-6" | 23'-8" | 29'-9" | 26'-9" |

For SI: 1 inch = 25.4 mm, 1 foot = 304.8 mm, 1 pound per square foot = 0.0479 kPa.

a. Deflection criterion: $L/240$ for total loads.

b. Ceiling dead load = 5 psf.

c. Bearing stiffeners are required at all bearing points and concentrated load locations.

TABLE R804.3.1(2)
CEILING JOIST SPANS
TWO EQUAL SPANS WITH BEARING STIFFENERS
10 lb per sq ft LIVE LOAD (NO ATTIC STORAGE)^{a, b, c} 33 ksi STEEL

| MEMBER DESIGNATION | ALLOWABLE SPAN (feet-inches) | | | | | |
|--------------------|---|---------|------------------|---------|---------------------|---------|
| | Lateral Support of Top (Compression) Flange | | | | | |
| | Unbraced | | Mid-Span Bracing | | Third-Point Bracing | |
| | Ceiling Joist Spacing (inches) | | | | | |
| | 16 | 24 | 16 | 24 | 16 | 24 |
| 350S162-33 | 12'-11" | 10'-11" | 13'-5" | 10'-11" | 13'-5" | 10'-11" |
| 350S162-43 | 14'-2" | 12'-8" | 15'-10" | 12'-11" | 15'-10" | 12'-11" |
| 350S162-54 | 15'-6" | 13'-10" | 17'-1" | 14'-6" | 17'-9" | 14'-6" |
| 350S162-68 | 17'-3" | 15'-3" | 18'-6" | 16'-1" | 19'-8" | 16'-1" |
| 350S162-97 | 20'-10" | 18'-4" | 21'-5" | 18'-10" | 21'-11" | 18'-10" |
| 550S162-33 | 14'-4" | 12'-11" | 16'-7" | 14'-1" | 17'-3" | 14'-1" |
| 550S162-43 | 16'-0" | 14'-1" | 17'-11" | 16'-1" | 20'-7" | 16'-10" |
| 550S162-54 | 17'-4" | 15'-6" | 19'-5" | 17'-6" | 23'-2" | 19'-0" |
| 550S162-68 | 19'-1" | 16'-11" | 20'-10" | 18'-8" | 25'-2" | 21'-5" |
| 550S162-97 | 22'-8" | 19'-9" | 23'-6" | 20'-11" | 27'-11" | 25'-1" |
| 800S162-33 | 16'-5" | 14'-10" | 19'-2" | 17'-3" | 23'-1" | 18'-3" |
| 800S162-43 | 17'-9" | 15'-11" | 20'-6" | 18'-5" | 25'-0" | 22'-6" |
| 800S162-54 | 19'-1" | 17'-1" | 21'-8" | 19'-6" | 26'-4" | 23'-9" |
| 800S162-68 | 20'-9" | 18'-6" | 23'-1" | 20'-9" | 28'-0" | 25'-2" |
| 800S162-97 | 24'-5" | 21'-6" | 26'-0" | 23'-2" | 31'-1" | 27'-9" |
| 1000S162-43 | 18'-11" | 17'-0" | 21'-11" | 19'-9" | 26'-8" | 24'-1" |
| 1000S162-54 | 20'-3" | 18'-2" | 23'-2" | 20'-10" | 28'-2" | 25'-5" |
| 1000S162-68 | 21'-11" | 19'-7" | 24'-7" | 22'-2" | 29'-10" | 26'-11" |
| 1000S162-97 | 25'-7" | 22'-7" | 27'-6" | 24'-6" | 33'-0" | 29'-7" |
| 1200S162-43 | 19'-11" | 17'-11" | 23'-1" | 20'-10" | 28'-3" | 25'-6" |
| 1200S162-54 | 21'-3" | 19'-1" | 24'-5" | 22'-0" | 29'-9" | 26'-10" |
| 1200S162-68 | 23'-0" | 20'-7" | 25'-11" | 23'-4" | 31'-6" | 28'-4" |
| 1000S162-97 | 26'-7" | 23'-6" | 28'-9" | 25'-10" | 34'-8" | 31'-1" |

For SI: 1 inch = 25.4 mm, 1 foot = 304.8 mm, 1 pound per square foot = 0.0479 kPa.

a. Deflection criterion: $L/240$ for total loads.

b. Ceiling dead load = 5 psf.

c. Bearing stiffeners are required at all bearing points and concentrated load locations.

TABLE R804.3.1(3)
CEILING JOIST SPANS
SINGLE SPANS WITH BEARING STIFFENERS
20 lb per sq ft LIVE LOAD (LIMITED ATTIC STORAGE)^{a, b, c} 33 ksi STEEL

| MEMBER DESIGNATION | ALLOWABLE SPAN (feet-inches) | | | | | |
|--------------------|---|---------|------------------|---------|---------------------|---------|
| | Lateral Support of Top (Compression) Flange | | | | | |
| | Unbraced | | Mid-Span Bracing | | Third-Point Bracing | |
| | Ceiling Joist Spacing (inches) | | | | | |
| | 16 | 24 | 16 | 24 | 16 | 24 |
| 350S162-33 | 8'-2" | 7'-2" | 9'-9" | 8'-1" | 9'-11" | 8'-1" |
| 350S162-43 | 8'-10" | 7'-10" | 11'-0" | 9'-5" | 11'-0" | 9'-7" |
| 350S162-54 | 9'-6" | 8'-6" | 11'-9" | 10'-3" | 11'-9" | 10'-3" |
| 350S162-68 | 10'-4" | 9'-2" | 12'-7" | 11'-0" | 12'-7" | 11'-0" |
| 350S162-97 | 12'-1" | 10'-8" | 14'-0" | 12'-0" | 14'-0" | 12'-0" |
| 550S162-33 | 9'-2" | 8'-3" | 12'-2" | 10'-2" | 12'-6" | 10'-5" |
| 550S162-43 | 10'-1" | 9'-1" | 13'-7" | 11'-7" | 14'-5" | 12'-2" |
| 550S162-54 | 10'-9" | 9'-8" | 14'-10" | 12'-10" | 15'-11" | 13'-6" |
| 550S162-68 | 11'-7" | 10'-4" | 16'-4" | 14'-0" | 17'-5" | 14'-11" |
| 550S162-97 | 13'-4" | 11'-10" | 18'-5" | 16'-2" | 20'-1" | 17'-1" |
| 800S162-33 | 10'-7" | 9'-6" | 15'-1" | 13'-0" | 16'-2" | 13'-7" |
| 800S162-43 | 11'-4" | 10'-2" | 16'-5" | 14'-6" | 18'-2" | 15'-9" |
| 800S162-54 | 12'-0" | 10'-9" | 17'-4" | 15'-6" | 19'-6" | 17'-0" |
| 800S162-68 | 12'-10" | 11'-6" | 18'-5" | 16'-6" | 20'-10" | 18'-3" |
| 800S162-97 | 14'-7" | 12'-11" | 20'-5" | 18'-3" | 22'-11" | 20'-5" |
| 1000S162-43 | 12'-1" | 10'-11" | 17'-7" | 15'-10" | 19'-11" | 17'-3" |
| 1000S162-54 | 12'-10" | 11'-6" | 18'-7" | 16'-9" | 21'-2" | 18'-10" |
| 1000S162-68 | 13'-8" | 12'-3" | 19'-8" | 17'-8" | 22'-4" | 20'-1" |
| 1000S162-97 | 15'-4" | 13'-8" | 21'-8" | 19'-5" | 24'-5" | 21'-11" |
| 1200S162-43 | 12'-9" | 11'-6" | 18'-7" | 16'-6" | 20'-9" | 18'-2" |
| 1200S162-54 | 13'-6" | 12'-2" | 19'-7" | 17'-8" | 22'-5" | 20'-2" |
| 1200S162-68 | 14'-4" | 12'-11" | 20'-9" | 18'-8" | 23'-7" | 21'-3" |
| 1000S162-97 | 16'-1" | 14'-4" | 22'-10" | 20'-6" | 25'-9" | 23'-2" |

For SI: 1 inch = 25.4 mm, 1 foot = 304.8 mm, 1 pound per square foot = 0.0479 kPa.

a. Deflection criterion: $L/240$ for total loads.

b. Ceiling dead load = 5 psf.

c. Bearing stiffeners are required at all bearing points and concentrated load locations.

TABLE R804.3.1(4)
CEILING JOIST SPANS
TWO EQUAL SPANS WITH BEARING STIFFENERS
20 lb per sq ft LIVE LOAD (LIMITED ATTIC STORAGE)^{a, b, c} 33 ksi STEEL

| MEMBER DESIGNATION | ALLOWABLE SPAN (feet-inches) | | | | | |
|--------------------|---|---------|------------------|---------|---------------------|---------|
| | Lateral Support of Top (Compression) Flange | | | | | |
| | Unbraced | | Mid-Span Bracing | | Third-Point Bracing | |
| | Ceiling Joist Spacing (inches) | | | | | |
| | 16 | 24 | 16 | 24 | 16 | 24 |
| 350S162-33 | 10'-2" | 8'-4" | 10'-2" | 8'-4" | 10'-2" | 8'-4" |
| 350S162-43 | 12'-1" | 9'-10" | 12'-1" | 9'-10" | 12'-1" | 9'-10" |
| 350S162-54 | 13'-3" | 11'-0" | 13'-6" | 11'-0" | 13'-6" | 11'-0" |
| 350S162-68 | 14'-7" | 12'-3" | 15'-0" | 12'-3" | 15'-0" | 12'-3" |
| 350S162-97 | 17'-6" | 14'-3" | 17'-6" | 14'-3" | 17'-6" | 14'-3" |
| 550S162-33 | 12'-5" | 10'-9" | 13'-2" | 10'-9" | 13'-2" | 10'-9" |
| 550S162-43 | 13'-7" | 12'-1" | 15'-6" | 12'-9" | 15'-8" | 12'-9" |
| 550S162-54 | 14'-11" | 13'-4" | 16'-10" | 14'-5" | 17'-9" | 14'-5" |
| 550S162-68 | 16'-3" | 14'-5" | 18'-0" | 16'-1" | 20'-0" | 16'-4" |
| 550S162-97 | 19'-1" | 16'-10" | 20'-3" | 18'-0" | 23'-10" | 19'-5" |
| 800S162-33 | 14'-3" | 12'-4" | 16'-7" | 12'-4" | 16'-7" | 12'-4" |
| 800S162-43 | 15'-4" | 13'-10" | 17'-9" | 16'-0" | 21'-8" | 17'-9" |
| 800S162-54 | 16'-5" | 14'-9" | 18'-10" | 16'-11" | 22'-11" | 20'-6" |
| 800S162-68 | 17'-9" | 15'-11" | 20'-0" | 18'-0" | 24'-3" | 21'-10" |
| 800S162-97 | 20'-8" | 18'-3" | 22'-3" | 19'-11" | 26'-9" | 24'-0" |
| 1000S162-43 | 16'-5" | 14'-9" | 19'-0" | 17'-2" | 23'-3" | 18'-11" |
| 1000S162-54 | 17'-6" | 15'-8" | 20'-1" | 18'-1" | 24'-6" | 22'-1" |
| 1000S162-68 | 18'-10" | 16'-10" | 21'-4" | 19'-2" | 25'-11" | 23'-4" |
| 1000S162-97 | 21'-8" | 19'-3" | 23'-7" | 21'-2" | 28'-5" | 25'-6" |
| 1200S162-43 | 17'-3" | 15'-7" | 20'-1" | 18'-2" | 24'-6" | 18'-3" |
| 1200S162-54 | 18'-5" | 16'-6" | 21'-3" | 19'-2" | 25'-11" | 23'-5" |
| 1200S162-68 | 19'-9" | 17'-8" | 22'-6" | 20'-3" | 27'-4" | 24'-8" |
| 1000S162-97 | 22'-7" | 20'-1" | 24'-10" | 22'-3" | 29'-11" | 26'-11" |

For SI: 1 inch = 25.4 mm, 1 foot = 304.8 mm, 1 pound per square foot = 0.0479 kPa.

- a. Deflection criterion: $L/240$ for total loads.
- b. Ceiling dead load = 5 psf.
- c. Bearing stiffeners are required at all bearing points and concentrated load locations.

TABLE R804.3.1(5)
CEILING JOIST SPANS
SINGLE SPANS WITHOUT BEARING STIFFENERS
10 lb per sq ft LIVE LOAD (NO ATTIC STORAGE)^{a, b} 33 ksi STEEL

| MEMBER DESIGNATION | ALLOWABLE SPAN (feet-inches) | | | | | |
|-----------------------|---|---------|------------------|---------|---------------------|---------|
| | Lateral Support of Top (Compression) Flange | | | | | |
| | Unbraced | | Mid-Span Bracing | | Third-Point Bracing | |
| | Ceiling Joist Spacing (inches) | | | | | |
| | 16 | 24 | 16 | 24 | 16 | 24 |
| 350S162-33 | 9'-5" | 8'-6" | 12'-2" | 10'-4" | 12'-2" | 10'-7" |
| 350S162-43 | 10'-3" | 9'-12" | 13'-2" | 11'-6" | 13'-2" | 11'-6" |
| 350S162-54 | 11'-1" | 9'-11" | 13'-9" | 12'-0" | 13'-9" | 12'-0" |
| 350S162-68 | 12'-1" | 10'-9" | 14'-8" | 12'-10" | 14'-8" | 12'-10" |
| 350S162-97 | 14'-4" | 12'-7" | 16'-10" | 14'-3" | 16'-4" | 14'-3" |
| 550S162-33 | 10'-7" | 9'-6" | 14'-10" | 12'-10" | 15'-11" | 13'-4" |
| 550S162-43 | 11'-8" | 10'-6" | 16'-4" | 14'-3" | 17'-10" | 15'-3" |
| 550S162-54 | 12'-6" | 11'-2" | 17'-7" | 15'-7" | 19'-5" | 16'-10" |
| 550S162-68 | 13'-6" | 12'-1" | 19'-2" | 17'-0" | 21'-0" | 18'-4" |
| 550S162-97 | 15'-9" | 13'-11" | 21'-8" | 19'-3" | 23'-5" | 20'-5" |
| 800S162-33 | — | — | — | — | — | — |
| 800S162-43 | 13'-0" | 11'-9" | 18'-10" | 17'-0" | 21'-6" | 19'-0" |
| 800S162-54 | 13'-10" | 12'-5" | 20'-0" | 18'-0" | 22'-9" | 20'-4" |
| 800S162-68 | 14'-11" | 13'-4" | 21'-3" | 19'-1" | 24'-1" | 21'-8" |
| 800S162-97 | 17'-1" | 15'-2" | 23'-10" | 21'-3" | 26'-7" | 23'-10" |
| 1000S162-43 | — | — | — | — | — | — |
| 1000S162-54 | 14'-9" | 13'-3" | 21'-4" | 19'-3" | 24'-4" | 22'-0" |
| 1000S162-68 | 15'-10" | 14'-2" | 22'-8" | 20'-5" | 25'-9" | 23'-2" |
| 1000S162-97 | 18'-0" | 16'-0" | 25'-3" | 22'-7" | 28'-3" | 25'-4" |
| 1200S162-43 | — | — | — | — | — | — |
| 1200S162-54 | — | — | — | — | — | — |
| 1200S162-68 | 16'-8" | 14'-11" | 23'-11" | 21'-6" | 27'-2" | 24'-6" |
| 1000S162-97 | 18'-9" | 16'-9" | 26'-6" | 23'-8" | 29'-9" | 26'-9" |

For SI: 1 inch = 25.4 mm, 1 foot = 304.8 mm, 1 pound per square foot = 0.0479 kPa.

a. Deflection criterion: $L/240$ for total loads.

b. Ceiling dead load = 5 psf.

TABLE R804.3.1(6)
CEILING JOIST SPANS
TWO EQUAL SPANS WITHOUT BEARING STIFFENERS
10 lb per sq ft LIVE LOAD (NO ATTIC STORAGE)^{a, b} 33 ksi STEEL

| MEMBER DESIGNATION | ALLOWABLE SPAN (feet-inches) | | | | | |
|--------------------|---|---------|------------------|---------|---------------------|---------|
| | Lateral Support of Top (Compression) Flange | | | | | |
| | Unbraced | | Mid-Span Bracing | | Third-Point Bracing | |
| | Ceiling Joist Spacing (inches) | | | | | |
| | 16 | 24 | 16 | 24 | 16 | 24 |
| 350S162-33 | 11'-9" | 8'-11" | 11'-9" | 8'-11" | 11'-9" | 8'-11" |
| 350S162-43 | 14'-2" | 11'-7" | 14'-11" | 11'-7" | 14'-11" | 11'-7" |
| 350S162-54 | 15'-6" | 13'-10" | 17'-1" | 13'-10" | 17'-7" | 13'-10" |
| 350S162-68 | 17'-3" | 15'-3" | 18'-6" | 16'-1" | 19'-8" | 16'-1" |
| 350S162-97 | 20'-10" | 18'-4" | 21'-5" | 18'-9" | 21'-11" | 18'-9" |
| 550S162-33 | 13'-4" | 9'-11" | 13'-4" | 9'-11" | 13'-4" | 9'-11" |
| 550S162-43 | 16'-0" | 13'-6" | 17'-9" | 13'-6" | 17'-9" | 13'-6" |
| 550S162-54 | 17'-4" | 15'-6" | 19'-5" | 16'-10" | 21'-9" | 16'-10" |
| 550S162-68 | 19'-1" | 16'-11" | 20'-10" | 18'-8" | 24'-11" | 20'-6" |
| 550S162-97 | 22'-8" | 20'-0" | 23'-9" | 21'-1" | 28'-2" | 25'-1" |
| 800S162-33 | — | — | — | — | — | — |
| 800S162-43 | 17'-9" | 15'-7" | 20'-6" | 15'-7" | 21'-0" | 15'-7" |
| 800S162-54 | 19'-1" | 17'-1" | 21'-8" | 19'-6" | 26'-4" | 23'-10" |
| 800S162-68 | 20'-9" | 18'-6" | 23'-1" | 20'-9" | 28'-0" | 25'-2" |
| 800S162-97 | 24'-5" | 21'-6" | 26'-0" | 23'-2" | 31'-1" | 27'-9" |
| 1000S162-43 | — | — | — | — | — | — |
| 1000S162-54 | 20'-3" | 18'-2" | 23'-2" | 20'-10" | 28'-2" | 21'-2" |
| 1000S162-68 | 21'-11" | 19'-7" | 24'-7" | 22'-2" | 29'-10" | 26'-11" |
| 1000S162-97 | 25'-7" | 22'-7" | 27'-6" | 24'-6" | 33'-0" | 29'-7" |
| 1200S162-43 | — | — | — | — | — | — |
| 1200S162-54 | — | — | — | — | — | — |
| 1200S162-68 | 23'-0" | 20'-7" | 25'-11" | 23'-4" | 31'-6" | 28'-4" |
| 1000S162-97 | 26'-7" | 23'-6" | 28'-9" | 25'-10" | 34'-8" | 31'-1" |

For SI: 1 inch = 25.4 mm, 1 foot = 304.8 mm, 1 pound per square foot = 0.0479 kPa.

a. Deflection criterion: $L/240$ for total loads.

b. Ceiling dead load = 5 psf.

**TABLE R804.3.1(7)
CEILING JOIST SPANS
SINGLE SPANS WITHOUT BEARING STIFFENERS
20 lb per sq ft LIVE LOAD (LIMITED ATTIC STORAGE)^{a, b} 33 ksi STEEL**

| MEMBER DESIGNATION | ALLOWABLE SPAN (feet-inches) | | | | | |
|-----------------------|---|---------|------------------|---------|---------------------|---------|
| | Lateral Support of Top (Compression) Flange | | | | | |
| | Unbraced | | Mid-Span Bracing | | Third-Point Bracing | |
| | Ceiling Joist Spacing (inches) | | | | | |
| | 16 | 24 | 16 | 24 | 16 | 24 |
| 350S162-33 | 8'-2" | 6'-10" | 9'-9" | 6'-10" | 9'-11" | 6'-10" |
| 350S162-43 | 8'-10" | 7'-10" | 11'-0" | 9'-5" | 11'-0" | 9'-7" |
| 350S162-54 | 9'-6" | 8'-6" | 11'-9" | 10'-3" | 11'-9" | 10'-3" |
| 350S162-68 | 10'-4" | 9'-2" | 12'-7" | 11'-0" | 12'-7" | 11'-0" |
| 350S162-97 | 12'-10" | 10'-8" | 13'-9" | 12'-0" | 13'-9" | 12'-0" |
| 550S162-33 | 9'-2" | 8'-3" | 12'-2" | 8'-5" | 12'-6" | 8'-5" |
| 550S162-43 | 10'-1" | 9'-1" | 13'-7" | 11'-8" | 14'-5" | 12'-2" |
| 550S162-54 | 10'-9" | 9'-8" | 14'-10" | 12'-10" | 15'-11" | 13'-6" |
| 550S162-68 | 11'-7" | 10'-4" | 16'-4" | 14'-0" | 17'-5" | 14'-11" |
| 550S162-97 | 13'-4" | 11'-10" | 18'-5" | 16'-2" | 20'-1" | 17'-4" |
| 800S162-33 | — | — | — | — | — | — |
| 800S162-43 | 11'-4" | 10'-1" | 16'-5" | 13'-6" | 18'-1" | 13'-6" |
| 800S162-54 | 20'-0" | 10'-9" | 17'-4" | 15'-6" | 19'-6" | 27'-0" |
| 800S162-68 | 12'-10" | 11'-6" | 18'-5" | 16'-6" | 20'-10" | 18'-3" |
| 800S162-97 | 14'-7" | 12'-11" | 20'-5" | 18'-3" | 22'-11" | 20'-5" |
| 1000S162-43 | — | — | — | — | — | — |
| 1000S162-54 | 12'-10" | 11'-6" | 18'-7" | 16'-9" | 21'-2" | 15'-5" |
| 1000S162-68 | 13'-8" | 12'-3" | 19'-8" | 17'-8" | 22'-4" | 20'-1" |
| 1000S162-97 | 15'-4" | 13'-8" | 21'-8" | 19'-5" | 24'-5" | 21'-11" |
| 1200S162-43 | — | — | — | — | — | — |
| 1200S162-54 | — | — | — | — | — | — |
| 1200S162-68 | 14'-4" | 12'-11" | 20'-9" | 18'-8" | 23'-7" | 21'-3" |
| 1000S162-97 | 16'-1" | 14'-4" | 22'-10" | 20'-6" | 25'-9" | 23'-2" |

For SI: 1 inch = 25.4 mm, 1 foot = 304.8 mm, 1 pound per square foot = 0.0479 kPa.

a. Deflection criterion: $L/240$ for total loads.

b. Ceiling dead load = 5 psf.

TABLE R804.3.1(8)
CEILING JOIST SPANS
TWO EQUAL SPANS WITHOUT BEARING STIFFENERS
20 lb per sq ft LIVE LOAD (LIMITED ATTIC STORAGE)^{a, b} 33 ksi STEEL

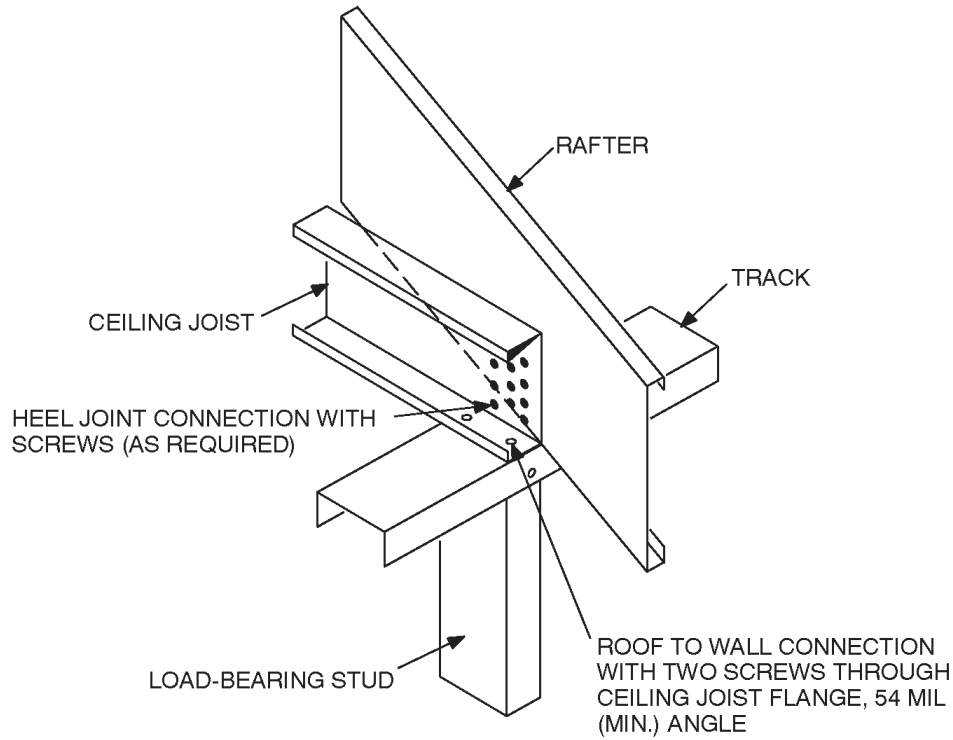
| MEMBER DESIGNATION | ALLOWABLE SPAN (feet-inches) | | | | | |
|--------------------|---|---------|------------------|---------|---------------------|---------|
| | Lateral Support of Top (Compression) Flange | | | | | |
| | Unbraced | | Mid-Span Bracing | | Third-Point Bracing | |
| | Ceiling Joist Spacing (inches) | | | | | |
| | 16 | 24 | 16 | 24 | 16 | 24 |
| 350S162-33 | 8'-1" | 6'-1" | 8'-1" | 6'-1" | 8'-1" | 6'-1" |
| 350S162-43 | 10'-7" | 8'-1" | 10'-7" | 8'-1" | 10'-7" | 8'-1" |
| 350S162-54 | 12'-8" | 9'-10" | 12'-8" | 9'-10" | 12'-8" | 9'-10" |
| 350S162-68 | 14'-7" | 11'-10" | 14'-11" | 11'-10" | 14'-11" | 11'-10" |
| 350S162-97 | 17'-6" | 14'-3" | 17'-6" | 14'-3" | 17'-6" | 14'-3" |
| 550S162-33 | 8'-11" | 6'-8" | 8'-11" | 6'-8" | 8'-11" | 6'-8" |
| 550S162-43 | 12'-3" | 9'-2" | 12'-3" | 9'-2" | 12'-3" | 9'-2" |
| 550S162-54 | 14'-11" | 11'-8" | 15'-4" | 11'-8" | 15'-4" | 11'-8" |
| 550S162-68 | 16'-3" | 14'-5" | 18'-0" | 15'-8" | 18'-10" | 14'-7" |
| 550S162-97 | 19'-1" | 16'-10" | 20'-3" | 18'-0" | 23'-9" | 19'-5" |
| 800S162-33 | — | — | — | — | — | — |
| 800S162-43 | 13'-11" | 9'-10" | 13'-11" | 9'-10" | 13'-11" | 9'-10" |
| 800S162-54 | 16'-5" | 13'-9" | 18'-8" | 13'-9" | 18'-8" | 13'-9" |
| 800S162-68 | 17'-9" | 15'-11" | 20'-0" | 18'-0" | 24'-1" | 18'-3" |
| 800S162-97 | 20'-8" | 18'-3" | 22'-3" | 19'-11" | 26'-9" | 24'-0" |
| 1000S162-43 | — | — | — | — | — | — |
| 1000S162-54 | 17'-6" | 13'-11" | 19'-1" | 13'-11" | 19'-1" | 13'-11" |
| 1000S162-68 | 18'-10" | 16'-10" | 21'-4" | 19'-2" | 25'-11" | 19'-7" |
| 1000S162-97 | 21'-8" | 19'-3" | 23'-7" | 21'-2" | 28'-5" | 25'-6" |
| 1200S162-43 | — | — | — | — | — | — |
| 1200S162-54 | — | — | — | — | — | — |
| 1200S162-68 | 19'-9" | 17'-8" | 22'-6" | 19'-8" | 26'-8" | 19'-8" |
| 1000S162-97 | 22'-7" | 20'-1" | 24'-10" | 22'-3" | 29'-11" | 26'-11" |

For SI: 1 inch = 25.4 mm, 1 foot = 304.8 mm, 1 pound per square foot = 0.0479 kPa.

a. Deflection criterion: $L/240$ for total loads.

b. Ceiling dead load = 5 psf.

ROOF-CEILING CONSTRUCTION



For SI: 1 mil = 0.0254 mm.

**FIGURE R804.3.1(1)
JOIST TO RAFTER CONNECTION**

**TABLE R804.3.1
NUMBER OF SCREWS REQUIRED FOR CEILING JOIST TO RAFTER CONNECTION^a**

| ROOF SLOPE | NUMBER OF SCREWS | | | | | | | | | | | | | | | | | | | |
|------------|------------------------|----|----|----|----|----|----|----|----|----|----|----|----|----|----|----|----|----|----|----|
| | Building width (feet) | | | | | | | | | | | | | | | | | | | |
| | 24 | | | | 28 | | | | 32 | | | | 36 | | | | 40 | | | |
| | Ground snow load (psf) | | | | | | | | | | | | | | | | | | | |
| | 20 | 30 | 50 | 70 | 20 | 30 | 50 | 70 | 20 | 30 | 50 | 70 | 20 | 30 | 50 | 70 | 20 | 30 | 50 | 70 |
| 3/12 | 5 | 6 | 9 | 11 | 5 | 7 | 10 | 13 | 6 | 8 | 11 | 15 | 7 | 8 | 13 | 17 | 8 | 9 | 14 | 19 |
| 4/12 | 4 | 5 | 7 | 9 | 4 | 5 | 8 | 10 | 5 | 6 | 9 | 12 | 5 | 7 | 10 | 13 | 6 | 7 | 11 | 14 |
| 5/12 | 3 | 4 | 6 | 7 | 4 | 4 | 6 | 8 | 4 | 5 | 7 | 10 | 5 | 5 | 8 | 11 | 5 | 6 | 9 | 12 |
| 6/12 | 3 | 3 | 5 | 6 | 3 | 4 | 6 | 7 | 4 | 4 | 6 | 8 | 4 | 5 | 7 | 9 | 4 | 5 | 8 | 10 |
| 7/12 | 3 | 3 | 4 | 6 | 3 | 3 | 5 | 7 | 3 | 4 | 6 | 7 | 4 | 4 | 6 | 8 | 4 | 5 | 7 | 9 |
| 8/12 | 2 | 3 | 4 | 5 | 3 | 3 | 5 | 6 | 3 | 4 | 5 | 7 | 3 | 4 | 6 | 8 | 4 | 4 | 6 | 8 |
| 9/12 | 2 | 3 | 4 | 5 | 3 | 3 | 4 | 6 | 3 | 3 | 5 | 6 | 3 | 4 | 5 | 7 | 3 | 4 | 6 | 8 |
| 10/12 | 2 | 2 | 4 | 5 | 2 | 3 | 4 | 5 | 3 | 3 | 5 | 6 | 3 | 3 | 5 | 7 | 3 | 4 | 6 | 7 |
| 11/12 | 2 | 2 | 3 | 4 | 2 | 3 | 4 | 5 | 3 | 3 | 4 | 6 | 3 | 3 | 5 | 6 | 3 | 4 | 5 | 7 |
| 12/12 | 2 | 2 | 3 | 4 | 2 | 3 | 4 | 5 | 2 | 3 | 4 | 5 | 3 | 3 | 5 | 6 | 3 | 4 | 5 | 7 |

For SI: 1 inch = 25.4 mm, 1 foot = 304.8 mm, 1 pound per square foot = 0.0479 kPa.

a. Screws shall be No. 10.

R804.3.2 Ceiling joist bracing. The bottom flanges of steel ceiling joists shall be laterally braced in accordance with Section R702. The top flanges of steel ceiling joists shall be laterally braced with a minimum of 33 mil (0.84 mm) C-section, 33 mil (0.84 mm) track section or 1½ inch by 33 mil (38 mm by 0.84 mm) continuous steel strapping as required in Tables R804.3.1(1) through R804.3.1(8). Lateral bracing shall be installed in accordance with Figure R804.3. C-section, tracks or straps shall be fastened to the top flange at each joist with at least one No. 8 screw and shall be fastened to blocking with at least two No. 8 screws. Blocking or bridging (X-bracing) shall be installed between joists in line with strap bracing at a maximum spacing of 12 feet (3658 mm) measured perpendicular to the joists, and at the termination of all straps. The third-point bracing span values from Tables R804.3.1(1) through R804.3.1(8) shall be used for straps installed at closer spacings than third-point bracing, or when sheathing is applied to the top of the ceiling joists.

R804.3.3 Allowable rafter spans. The horizontal projection of the rafter span, as shown in Figure R804.3, shall not exceed the limits set forth in Table R804.3.3(1). Wind speeds shall be converted to equivalent ground snow loads in accordance with Table R804.3.3(2). Rafter spans shall be selected based on the higher of the ground snow load or the equivalent snow load converted from the wind speed. When required, a rafter support brace shall be a minimum of 350S162-33 C-section with maximum length of 8 feet (2438 mm) and shall be connected to a ceiling joist and rafter with four No. 10 screws at each end.

R804.3.3.1 Rafter framing. Rafters shall be connected to a parallel ceiling joist to form a continuous tie between exterior walls in accordance with Figures R804.3 and R804.3.1(1) and Table R804.3.1. Rafters shall be connected to a ridge member with a minimum 2-inch by 2-inch (51 mm by 51 mm) clip angle fastened with minimum No. 10 screws to the ridge member in accordance with Figure R804.3.3.1 and Table R804.3.3.1. The clip angle shall have a minimum steel thickness as the rafter member and shall extend the full depth of the rafter member. The ridge member shall be fabricated from a C-section and a track section, which shall be of a minimum size and steel thickness as the adjacent rafters and shall be installed in accordance with Figure R804.3.3.1.

R804.3.3.2 Roof cantilevers. Roof cantilevers shall not exceed 24 inches (610 mm) in accordance with Figure R804.3. Roof cantilevers shall be supported by a header in accordance with Section R603.6 or shall be supported by the floor framing in accordance with Section R505.3.7.

R804.3.4 Rafter bottom flange bracing. The bottom flanges of steel rafters shall be continuously braced with a minimum 33-mil (0.84 mm) C-section, 33-mil (0.84 mm) track section, or a 1½-inch by 33-mil (38 mm by 0.84 mm) steel strapping at a maximum spacing of 8 feet (2438 mm) as measured parallel to the rafters. Bracing shall be installed in accordance with Figure R804.3. The C-section, track section, or straps shall be fastened to blocking with at least two No. 8 screws. Blocking or bridging (X-bracing) shall be

installed between rafters in-line with the continuous bracing at a maximum spacing of 12 feet (3658 mm) measured perpendicular to the rafters and at the termination of all straps. The ends of continuous bracing shall be fastened to blocking with at least two No. 8 screws.

R804.3.5 Cutting and notching. Flanges and lips of load-bearing steel roof framing members shall not be cut or notched. Holes in webs shall be in accordance with Section R804.2.

R804.3.6 Hole patching. Web holes not conforming to the requirements in Section R804.2 shall be designed in accordance with one of the following:

1. Framing members shall be replaced or designed in accordance with accepted engineering practices when web holes exceed the following size limits:
 - 1.1. The depth of the hole, measured across the web, exceeds 70 percent of the flat width of the web; or,
 - 1.2. The length of the hole, measured along the web, exceeds 10 inches (254 mm) or the depth of the web, whichever is greater.
2. Web holes not exceeding the dimensional requirements in Section R804.3.6, Item 1 shall be patched with a solid steel plate, stud section, or track section in accordance with Figure R804.3.6. The steel patch shall be of a minimum thickness as the receiving member and shall extend at least 1 inch (25 mm) beyond all edges of the hole. The steel patch shall be fastened to the web of the receiving member with No. 8 screws spaced no greater than 1 inch (25 mm) center-to-center along the edges of the patch with minimum edge distance of ½ inch (13 mm).

R804.3.7 Splicing. Rafters and other structural members, except ceiling joists, shall not be spliced. Splices in ceiling joists shall only be permitted at interior bearing points and shall be constructed in accordance with Figure R804.3.7(1). Spliced ceiling joists shall be connected with the same number and size of screws on connection. Splicing of tracks shall conform to Figure R804.3.7(2).

R804.3.8 Bearing stiffener. A bearing stiffener shall be fabricated from a minimum 33-mil (0.84 mm) C-section or track section. Each stiffener shall be fastened to the web of the ceiling joist with a minimum of four No. 8 screws equally spaced as shown in Figure R804.3.8. Stiffeners shall extend across the full depth of the web and shall be installed on either side of the web.

R804.3.9 Headers. Roof-ceiling framing above wall openings shall be supported on headers. The allowable spans for headers in bearing walls shall not exceed the values set forth in Table R603.6(1).

R804.3.10 Framing of opening. Openings in roof and ceiling framing shall be framed with headers and trimmers between ceiling joists or rafters. Header joist spans shall not exceed 4 feet (1219 mm). Header and trimmer joists shall be fabricated from joist and track sections, which shall be of a minimum size and thickness in accordance with Figures R804.3.10(1) and R804.3.10(2). Each header joist shall be

TABLE R804.3.3(1)
ALLOWABLE HORIZONTAL RAFTER SPANS^{a, b, c} 33 ksi STEEL

| MEMBER DESIGNATION | ALLOWABLE SPAN MEASURED HORIZONTALLY (feet-inches) | | | | | | | |
|--------------------|--|---------|---------|---------|---------|---------|---------|---------|
| | Ground Snow Load | | | | | | | |
| | 20 psf | | 30 psf | | 50 psf | | 70 psf | |
| | Rafter spacing (in) | | | | | | | |
| | 16 | 24 | 16 | 24 | 16 | 24 | 16 | 24 |
| 550S162-33 | 14'-0" | 11'-5" | 11'-10" | 9'-8" | 9'-5" | 7'-8" | 8'-1" | 6'-7" |
| 550S162-43 | 16'-6" | 13'-10" | 14'-4" | 11'-9" | 11'-5" | 9'-4" | 9'-10" | 8'-0" |
| 550S162-54 | 17'-9" | 15'-6" | 15'-6" | 13'-2" | 12'-11" | 10'-6" | 11'-1" | 9'-0" |
| 550S162-68 | 19'-0" | 16'-7" | 16'-8" | 14'-7" | 14'-1" | 11'-10" | 12'-5" | 10'-2" |
| 550S162-97 | 21'-2" | 18'-6" | 18'-7" | 16'-2" | 15'-8" | 13'-8" | 14'-0" | 12'-2" |
| 800S162-33 | 17'-0" | 13'-11" | 14'-5" | 11'-9" | 11'-6" | 7'-9" | 8'-6" | 5'-8" |
| 800S162-43 | 21'-1" | 17'-3" | 17'-10" | 14'-7" | 14'-3" | 11'-7" | 12'-2" | 9'-11" |
| 800S162-54 | 23'-11" | 20'-4" | 21'-0" | 17'-3" | 16'-10" | 13'-9" | 14'-5" | 11'-9" |
| 800S162-68 | 25'-9" | 22'-6" | 22'-7" | 19'-5" | 19'-0" | 15'-6" | 16'-3" | 13'-3" |
| 800S162-97 | 28'-9" | 25'-1" | 25'-2" | 22'-0" | 21'-3" | 18'-7" | 19'-0" | 16'-0" |
| 1000S162-43 | 23'-4" | 19'-1" | 19'-9" | 16'-2" | 15'-9" | 12'-11" | 13'-6" | 10'-0" |
| 1000S162-54 | 27'-8" | 22'-7" | 23'-5" | 19'-1" | 18'-8" | 15'-3" | 16'-0" | 13'-1" |
| 1000S162-68 | 30'-11" | 27'-0" | 27'-2" | 22'-11" | 22'-5" | 18'-3" | 19'-2" | 15'-8" |
| 1000S162-97 | 34'-7" | 30'-2" | 30'-4" | 26'-6" | 25'-7" | 22'-1" | 22'-10" | 18'-11" |
| 1200S162-43 | 25'-5" | 20'-9" | 21'-6" | 17'-6" | 17'-1" | 11'-5" | 12'-6" | 8'-6" |
| 1200S162-54 | 30'-0" | 24'-6" | 25'-5" | 20'-9" | 20'-3" | 16'-7" | 17'-5" | 14'-2" |
| 1200S162-68 | 35'-5" | 28'-11" | 30'-0" | 24'-6" | 23'-11" | 19'-6" | 20'-6" | 16'-9" |
| 1200S162-97 | 40'-4" | 35'-3" | 35'-5" | 30'-11" | 29'-10" | 25'-5" | 26'-8" | 21'-9" |

For SI: 1 inch = 25.4 mm, 1 foot = 304.8 mm, 1 pound per square foot = 0.0479 kPa.

- a. Table provides maximum horizontal rafter spans in feet and inches for slopes between 3:12 and 12:12.
- b. Deflection criterion: $L/240$ for live loads and $L/180$ for total loads.
- c. Roof dead load = 12 psf.

TABLE R804.3.3(2)
BASIC WIND SPEED TO EQUIVALENT SNOW LOAD CONVERSION

| BASIC WIND SPEED AND EXPOSURE | | EQUIVALENT GROUND SNOW LOAD (psf) | | | | | | | | | |
|-------------------------------|---------|-----------------------------------|------|------|------|------|------|------|-------|-------|-------|
| | | Roof slope | | | | | | | | | |
| | | 3:12 | 4:12 | 5:12 | 6:12 | 7:12 | 8:12 | 9:12 | 10:12 | 11:12 | 12:12 |
| Exp. A/B | Exp. C | | | | | | | | | | |
| 85 mph | — | 20 | 20 | 20 | 20 | 20 | 20 | 30 | 30 | 30 | 30 |
| 100 mph | 85 mph | 20 | 20 | 20 | 20 | 30 | 30 | 30 | 30 | 50 | 50 |
| 110 mph | 100 mph | 20 | 20 | 20 | 20 | 30 | 50 | 50 | 50 | 50 | 50 |
| — | 110 mph | 30 | 30 | 30 | 50 | 50 | 50 | 70 | 70 | 70 | — |

For SI: 1 mile per hour = 0.447 m/s, 1 pound per square foot = 0.0479 kPa.

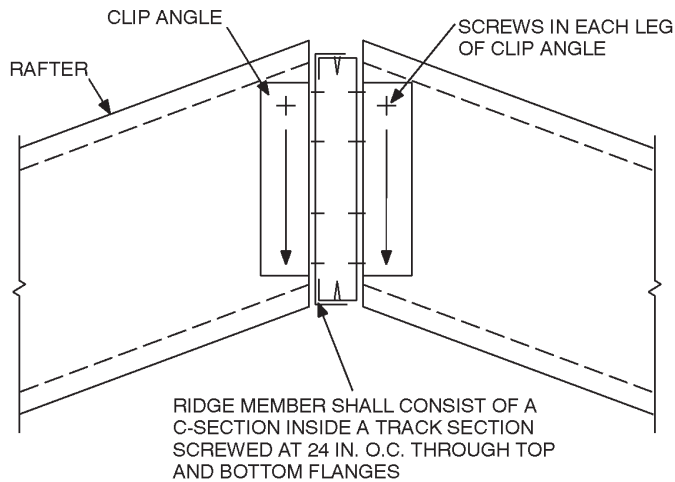
connected to a trimmer joist with a minimum of four 2-inch by 2-inch (51 by 51 mm) clip angles. Each clip angle shall be fastened to both the header and trimmer joists with four No. 8 screws, evenly spaced, through each leg of the clip angle. The clip angles shall have a steel thickness not less than that of the floor joist.

R804.4 Roof tie-down. Roof assemblies subject to wind uplift pressures of 20 pounds per square foot (0.96 kN/m²) or greater, as established in Table R301.2(2), shall have rafter-to-bearing wall ties provided in accordance with Table R802.11.

TABLE R804.3.3.1
NUMBER OF SCREWS REQUIRED AT EACH LEG OF CLIP
ANGLE FOR RAFTER TO RIDGE MEMBER CONNECTION^a

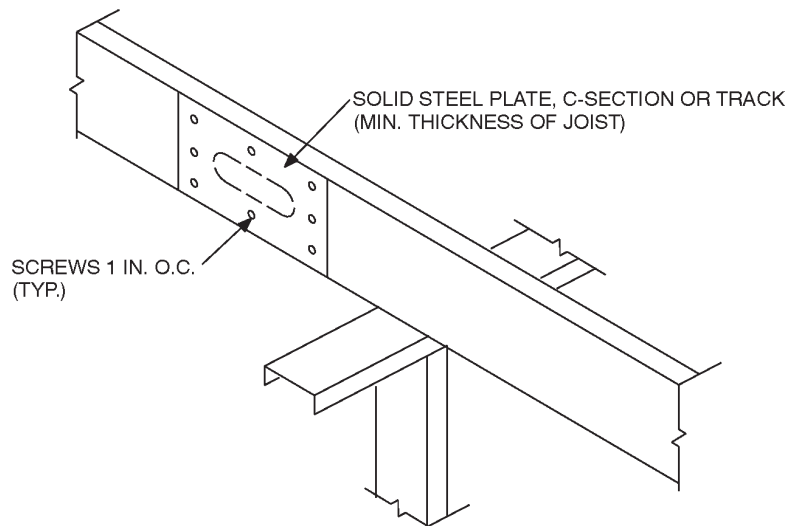
| BUILDING WIDTH (feet) | NUMBER OF SCREWS | | | |
|--------------------------|------------------------|----------|----------|----------|
| | Ground snow load (psf) | | | |
| | 0 to 20 | 21 to 30 | 31 to 50 | 51 to 70 |
| 24 | 2 | 2 | 3 | 4 |
| 28 | 2 | 3 | 4 | 5 |
| 32 | 2 | 3 | 4 | 5 |
| 36 | 3 | 3 | 5 | 6 |
| 40 | 3 | 4 | 5 | 7 |

For SI: 1 inch = 25.4 mm, 1 foot = 304.8 mm, 1 pound per square foot = 0.0479 kPa.
 a. Screws shall be No. 10 minimum.



For SI: 1 inch = 25.4 mm.

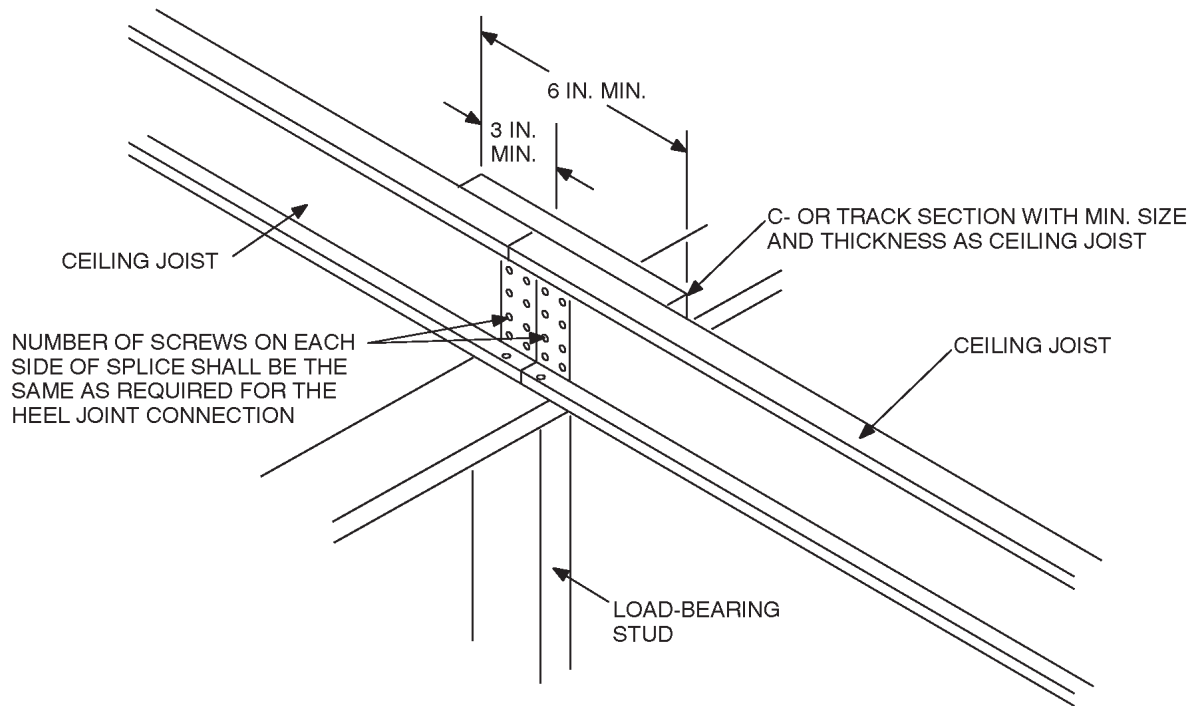
FIGURE R804.3.3.1
RIDGE BOARD CONNECTION



For SI: 1 inch = 25.4 mm.

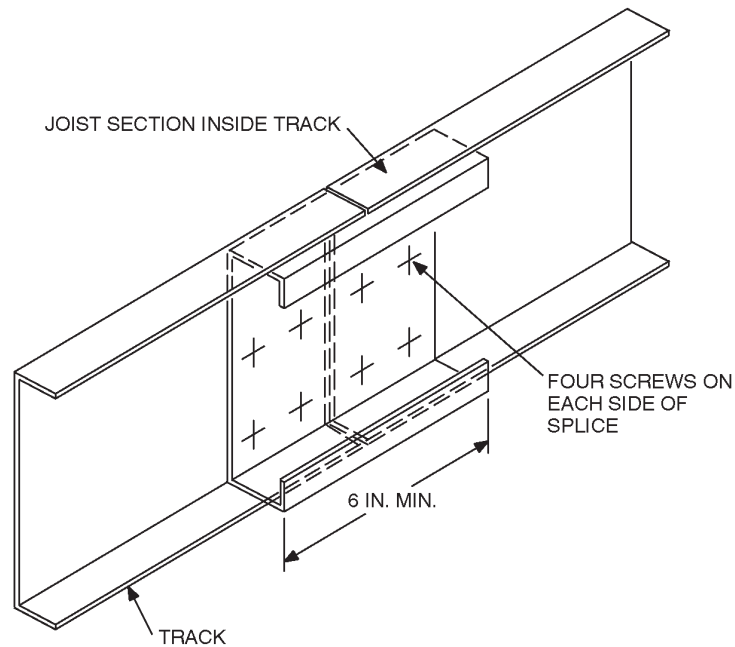
FIGURE R804.3.6
HOLE PATCHING

ROOF-CEILING CONSTRUCTION



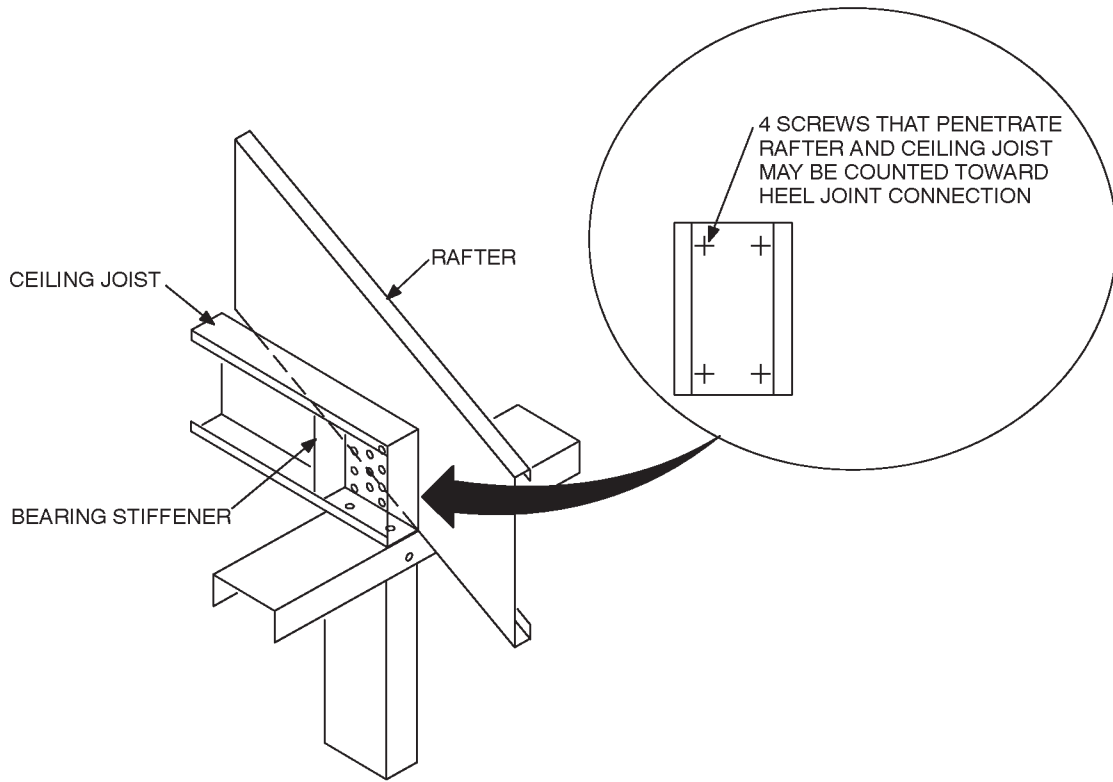
For SI: 1 inch = 25.4 mm.

**FIGURE R804.3.7(1)
SPLICED CEILING JOISTS**

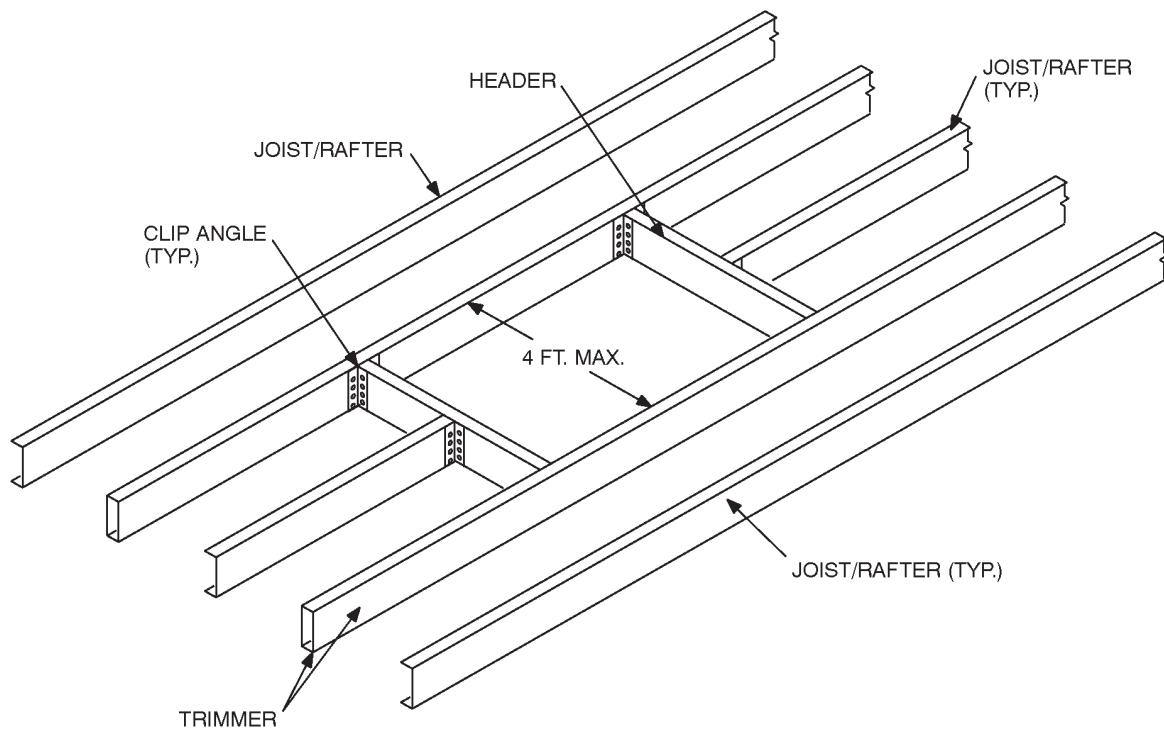


For SI: 1 inch = 25.4 mm.

**FIGURE R804.3.7(2)
TRACK SPLICE**

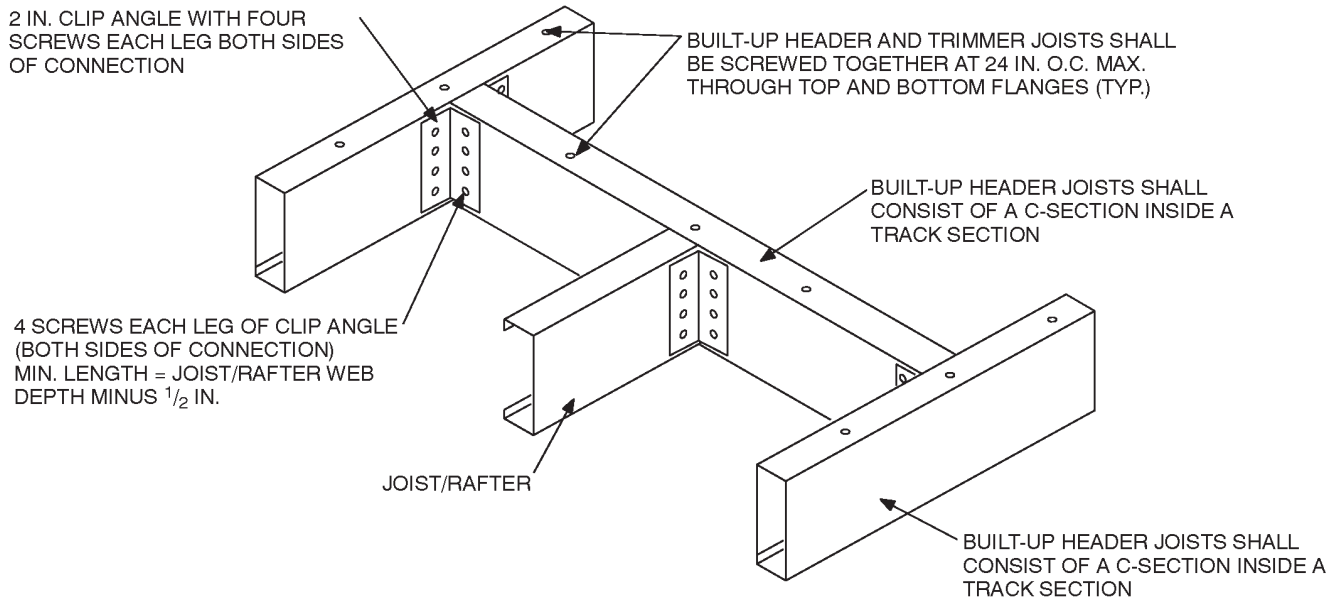


**FIGURE R804.3.8
BEARING STIFFENER**



**FIGURE R804.3.10(1)
ROOF OPENING**

For SI: 1 foot = 304.8 mm.



For SI: 1 inch = 25.4 mm.

FIGURE R804.3.10(2)
HEADER TO TRIMMER CONNECTION

SECTION R805
CEILING FINISHES

R805.1 Ceiling installation. Ceilings shall be installed in accordance with the requirements for interior wall finishes as provided in Section R702.

SECTION R806
ROOF VENTILATION

R806.1 Ventilation required. Enclosed attics and enclosed rafter spaces formed where ceilings are applied directly to the underside of roof rafters shall have cross ventilation for each separate space by ventilating openings protected against the entrance of rain or snow. Ventilating openings shall be provided with corrosion-resistant wire mesh, with $\frac{1}{8}$ inch (3.2 mm) minimum to $\frac{1}{4}$ inch (6 mm) maximum openings.

R806.2 Minimum area. The total net free ventilating area shall not be less than $\frac{1}{150}$ of the area of the space ventilated except that reduction of the total area to $\frac{1}{300}$ is permitted, provided that at least 50 percent and not more than 80 percent of the required ventilating area is provided by ventilators located in the upper portion of the space to be ventilated at least 3 feet (914 mm) above the eave or cornice vents with the balance of the required ventilation provided by eave or cornice vents. As an alternative, the net free cross-ventilation area may be reduced to $\frac{1}{300}$ when a vapor barrier having a transmission rate not exceeding 1 perm (5.7×10^{-11} kg/s · m² · Pa) is installed on the warm-in-winter side of the ceiling.

R806.3 Vent and insulation clearance. Where eave or cornice vents are installed, insulation shall not block the free flow of

air. A minimum of a 1-inch (25 mm) space shall be provided between the insulation and the roof sheathing and at the location of the vent.

R806.4 Conditioned attic assemblies. Unvented conditioned attic assemblies (spaces between the ceiling joists of the top story and the roof rafters) are permitted under the following conditions:

1. No interior vapor retarders are installed on the ceiling side (attic floor) of the unvented attic assembly.
2. An air-impermeable insulation is applied in direct contact to the underside/interior of the structural roof deck. "Air-impermeable" shall be defined by ASTM E 283.

Exception: In Zones 2B and 3B, insulation is not required to be air impermeable.

3. In the warm humid locations as defined in Section N1101.2.1:
 - 3.1. For asphalt roofing shingles: A 1-perm (5.7×10^{-11} kg/s · m² · Pa) or less vapor retarder (determined using Procedure B of ASTM E 96) is placed to the exterior of the structural roof deck; that is, just above the roof structural sheathing.
 - 3.2. For wood shingles and shakes: a minimum continuous $\frac{1}{4}$ -inch (6 mm) vented air space separates the shingles/shakes and the roofing felt placed over the structural sheathing.
4. In Zones 3 through 8 as defined in Section N1101.2, sufficient insulation is installed to maintain the monthly average temperature of the condensing surface above 45°F (7°C). The condensing surface is defined as either

the structural roof deck or the interior surface of an air-impermeable insulation applied in direct contact with the underside/interior of the structural roof deck. “Air-impermeable” is quantitatively defined by ASTM E 283. For calculation purposes, an interior temperature of 68°F (20°C) is assumed. The exterior temperature is assumed to be the monthly average outside temperature.

SECTION R807 ATTIC ACCESS

R807.1 Attic access. Buildings with combustible ceiling or roof construction shall have an attic access opening to attic areas that exceed 30 square feet (2.8 m²) and have a vertical height of 30 inches (762 mm) or more.

The rough-framed opening shall not be less than 22 inches by 30 inches (559 mm by 762 mm) and shall be located in a hallway or other readily accessible location. A 30-inch (762 mm) minimum unobstructed headroom in the attic space shall be provided at some point above the access opening. See Section M1305.1.3 for access requirements where mechanical equipment is located in attics.

SECTION R808 INSULATION CLEARANCE

R808.1 Combustible insulation. Combustible insulation shall be separated a minimum of 3 inches (76 mm) from recessed luminaires, fan motors and other heat-producing devices.

Exception: Where heat-producing devices are listed for lesser clearances, combustible insulation complying with the listing requirements shall be separated in accordance with the conditions stipulated in the listing.

Recessed luminaires installed in the building thermal envelope shall meet the requirements of Section N1102.4.3.

