

SECTION II—COLUMNS

TABLE 2.1.1—REINFORCED CONCRETE COLUMNS
MINIMUM DIMENSION 0" TO LESS THAN 6"

ITEM CODE	MINIMUM DIMENSION	CONSTRUCTION DETAILS	PERFORMANCE		REFERENCE NUMBER			NOTES	REC. HOURS
			LOAD	TIME	PRE-BMS-92	BMS-92	POST-BMS-92		
C-6-RC-1	6"	6" × 6" square columns; gravel aggregate concrete (4030 psi); Reinforcement: vertical, four 7/8" rebars; horizontal, 5/16" ties at 6" pitch; Cover: 1".	34.7 tons	62 min.			7	1, 2	1
C-6-RC-2	6"	6" × 6" square columns; gravel aggregate concrete (4200 psi); Reinforcement: vertical, four 1/2" rebars; horizontal, 5/16" ties at 6" pitch; Cover: 1".	21 tons	69 min.			7	1, 2	1

Notes:
1. Collapse.
2. British Test.

FIGURE 2.1.2—REINFORCED CONCRETE COLUMNS
MINIMUM DIMENSION 10" TO LESS THAN 12"

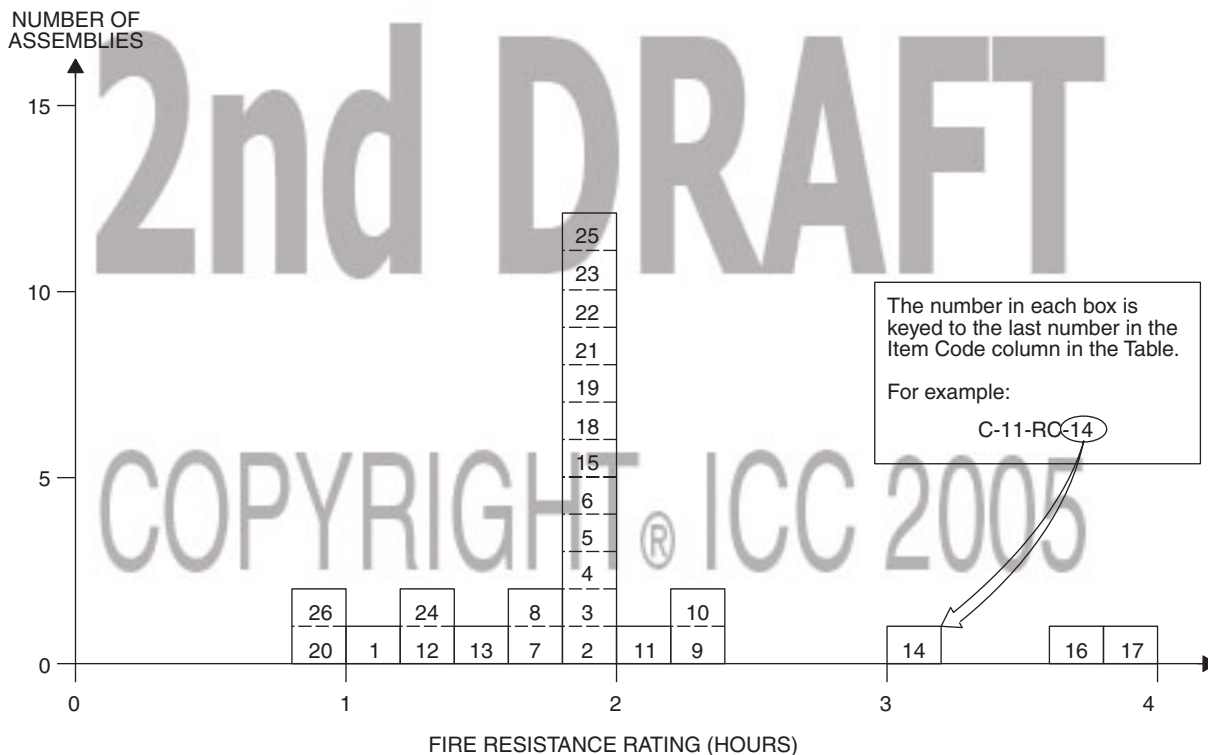

**TABLE 2.1.2—REINFORCED CONCRETE COLUMNS
MINIMUM DIMENSION 10" TO LESS THAN 12"**

ITEM CODE	MINIMUM DIMENSION	CONSTRUCTION DETAILS	PERFORMANCE		REFERENCE NUMBER			NOTES	REC. HOURS
			LOAD	TIME	PRE-BMS-92	BMS-92	POST-BMS-92		
C-10-RC-1	10"	10" square columns; aggregate concrete (4260 psi); Reinforcement: vertical, four 1 ¹ / ₄ " rebars; horizontal, 3 ³ / ₈ " ties at 6" pitch; Cover: 1 ¹ / ₄ ".	92.2 tons	1 hr. 2 min.			7	1	1
C-10-RC-2	10"	10" square columns; aggregate concrete (2325 psi); Reinforcement: vertical, four 1/2" rebars; horizontal, 5 ⁵ / ₁₆ " ties at 6" pitch; Cover: 1".	46.7 tons	1 hr. 52 min.			7	1	1 ³ / ₄
C-10-RC-3	10"	10" square columns; aggregate concrete (5370 psi); Reinforcement: vertical, four 1/2" rebars; horizontal, 5 ⁵ / ₁₆ " ties at 6" pitch; Cover: 1".	46.5 tons	2 hrs.			7	2, 3, 11	2
C-10-RC-4	10"	10" square columns; aggregate concrete (5206 psi); Reinforcement: vertical, four 1/2" rebars; horizontal, 5 ⁵ / ₁₆ " ties at 6" pitch; Cover: 1".	46.5 tons	2 hrs.			7	2, 7	2
C-10-RC-5	10"	10" square columns; aggregate concrete (5674 psi); Reinforcement: vertical, four 1/2" rebars; horizontal, 5 ⁵ / ₁₆ " ties at 6" pitch; Cover: 1".	46.7 tons	2 hrs.			7	1	2
C-10-RC-6	10"	10" square columns; aggregate concrete (5150 psi); Reinforcement: vertical, four 1 ¹ / ₂ " rebars; horizontal, 5 ⁵ / ₁₆ " ties at 6" pitch; Cover: 1".	66 tons	1 hr. 43 min.			7	1	1 ³ / ₄
C-10-RC-7	10"	10" square columns; aggregate concrete (5580 psi); Reinforcement: vertical, four 1/2" rebars; horizontal, 5 ⁵ / ₁₆ " ties at 6" pitch; Cover: 1 ¹ / ₈ ".	62.5 tons	1 hr. 38 min.			7	1	1 ¹ / ₂
C-10-RC-8	10"	10" square columns; aggregate concrete (4080 psi); Reinforcement: vertical, four 1 ¹ / ₈ " rebars; horizontal, 5 ⁵ / ₁₆ " ties at 6" pitch; Cover: 1 ¹ / ₈ ".	72.8 tons	1 hr. 48 min.			7	1	1 ³ / ₄
C-10-RC-9	10"	10" square columns; aggregate concrete (2510 psi); Reinforcement: vertical, four 1/2" rebars; horizontal, 5 ⁵ / ₁₆ " ties at 6" pitch; Cover: 1".	51 tons	2 hrs. 16 min.			7	1	2 ¹ / ₄
C-10-RC-10	10"	10" square columns; aggregate concrete (2170 psi); Reinforcement: vertical, four 1/2" rebars; horizontal, 5 ⁵ / ₁₆ " ties at 6" pitch; Cover: 1".	45 tons	2 hrs. 14 min.			7	12	2 ¹ / ₄
C-10-RC-11	10"	10" square columns; gravel aggregate concrete (4015 psi); Reinforcement: vertical, four 1/2" rebars; horizontal, 5 ⁵ / ₁₆ " ties at 6" pitch; Cover: 1 ¹ / ₈ ".	46.5 tons	2 hrs. 6 min.			7	1	2

(Continued)

**TABLE 2.1.2—REINFORCED CONCRETE COLUMNS
MINIMUM DIMENSION 10" TO LESS THAN 12"—(Continued)**

ITEM CODE	MINIMUM DIMENSION	CONSTRUCTION DETAILS	PERFORMANCE		REFERENCE NUMBER			NOTES	REC. HOURS
			LOAD	TIME	PRE-BMS-92	BMS-92	POST-BMS-92		
C-11-RC-12	11"	11" square columns; gravel aggregate concrete (4150 psi); Reinforcement: vertical, four 1 ¹ / ₄ " rebars; horizontal, ³ / ₈ " ties at 7 ¹ / ₂ " pitch; Cover: 1 ¹ / ₂ ".	61 tons	1 hr. 23 min.			7	1	1 ¹ / ₄
C-11-RC-13	11"	11" square columns; gravel aggregate concrete (4380 psi); Reinforcement: vertical, four 1 ¹ / ₄ " rebars; horizontal, ³ / ₈ " ties at 7 ¹ / ₂ " pitch; Cover: 1 ¹ / ₂ ".	61 tons	1 hr. 26 min.			7	1	1 ¹ / ₄
C-11-RC-14	11"	11" square columns; gravel aggregate concrete (4140 psi); Reinforcement: vertical, four 1 ¹ / ₄ " rebars; horizontal, ³ / ₈ " ties at 7 ¹ / ₂ " pitch; steel mesh around reinforcement; Cover: 1 ¹ / ₂ ".	61 tons	3 hrs. 9 min.			7	1	3
C-11-RC-15	11"	11" square columns; slag aggregate concrete (3690 psi); Reinforcement: vertical, four 1 ¹ / ₄ " rebars; horizontal, ³ / ₈ " ties at 7 ¹ / ₂ " pitch; Cover: 1 ¹ / ₂ ".	91 tons	2 hrs.			7	2, 3, 4, 5	2
C-11-RC-16	11"	11" square columns; limestone aggregate concrete (5230 psi); Reinforcement: vertical, four 1 ¹ / ₄ " rebars; horizontal, ³ / ₈ " ties at 7 ¹ / ₂ " pitch; Cover: 1 ¹ / ₂ ".	91.5 tons	3 hrs. 41 min.			7	1	3 ¹ / ₂
C-11-RC-17	11"	11" square columns; limestone aggregate concrete (5530 psi); Reinforcement: vertical, four 1 ¹ / ₄ " rebars; horizontal, ³ / ₈ " ties at 7 ¹ / ₂ " pitch; Cover: 1 ¹ / ₂ ".	91.5 tons	3 hrs. 47 min.			7	1	3 ¹ / ₂
C-11-RC-18	11"	11" square columns; limestone aggregate concrete (5280 psi); Reinforcement: vertical, four 1 ¹ / ₄ " rebars; horizontal, ³ / ₈ " ties at 7 ¹ / ₂ " pitch; Cover: 1 ¹ / ₂ ".	91.5 tons	2 hrs.			7	2, 3, 4, 6	2
C-11-RC-19	11"	11" square columns; limestone aggregate concrete (4180 psi); Reinforcement: vertical, four ⁵ / ₈ " rebars; horizontal, ³ / ₈ " ties at 7" pitch; Cover: 1 ¹ / ₂ ".	71.4 tons	2 hrs.			7	2, 7	2
C-11-RC-20	11"	11" square columns; gravel concrete (4530 psi); Reinforcement: vertical, four ⁵ / ₈ " rebars; horizontal, ³ / ₈ " ties at 7" pitch; Cover: 1 ¹ / ₂ " with ¹ / ₂ " plaster.	58.8 tons	2 hrs.			7	2, 3, 9	1 ¹ / ₄
C-11-RC-21	11"	11" square columns; gravel concrete (3520 psi); Reinforcement: vertical, four ⁵ / ₈ " rebars; horizontal, ³ / ₈ " ties at 7" pitch; Cover: 1 ¹ / ₂ ".	Variable	1 hr. 24 min.			7	1, 8	2

(Continued)

**TABLE 2.1.2—REINFORCED CONCRETE COLUMNS
MINIMUM DIMENSION 10" TO LESS THAN 12"—(Continued)**

ITEM CODE	MINIMUM DIMENSION	CONSTRUCTION DETAILS	PERFORMANCE		REFERENCE NUMBER			NOTES	REC. HOURS
			LOAD	TIME	PRE-BMS-92	BMS-92	POST-BMS-92		
C-11-RC-22	11"	11" square columns; aggregate concrete (3710 psi); Reinforcement: vertical, four 5/8" rebars; horizontal, 3/8" ties at 7" pitch; Cover: 1 1/2".	58.8 tons	2 hrs.			7	2, 3, 10	2
C-11-RC-23	11"	11" square columns; aggregate concrete (3190 psi); Reinforcement: vertical, four 5/8" rebars; horizontal, 3/8" ties at 7" pitch; Cover: 1 1/2".	58.8 tons	2 hrs.			7	2, 3, 10	2
C-11-RC-24	11"	11" square columns; aggregate concrete (4860 psi); Reinforcement: vertical, four 5/8" rebars; horizontal, 3/8" ties at 7" pitch; Cover: 1 1/2".	86.1 tons	1 hr. 20 min.			7	1	1 1/3
C-11-RC-25	11"	11" square columns; aggregate concrete (4850 psi); Reinforcement: vertical, four 5/8" rebars; horizontal, 3/8" ties at 7" pitch; Cover: 1 1/2".	58.8 tons	1 hr. 59 min.			7	1	1 3/4
C-11-RC-26	11"	11" square columns; aggregate concrete (3834 psi); Reinforcement: vertical, four 5/8" rebars; horizontal, 5/16" ties at 4 1/2" pitch; Cover: 1 1/2".	71.4 tons	53 min.			7	1	3/4

1. Failure mode - collapse.
2. Passed 2 hour fire exposure.
3. Passed hose stream test.
4. Reloaded effectively after 48 hours but collapsed at load in excess of original test load.
5. Failing load was 150 tons.
6. Failing load was 112 tons.
7. Failed during hose stream test.
8. Range of load 58.8 tons (initial) to 92 tons (92 minutes) to 60 tons (80 minutes).
9. Collapsed at 44 tons in reload after 96 hours.
10. Withstood reload after 72 hours.
11. Collapsed on reload after 48 hours.

COPYRIGHT® ICC 2005

**TABLE 2.1.3—REINFORCED CONCRETE COLUMNS
MINIMUM DIMENSION 12" TO LESS THAN 14"**

ITEM CODE	MINIMUM DIMENSION	CONSTRUCTION DETAILS	PERFORMANCE		REFERENCE NUMBER			NOTES	REC. HOURS
			LOAD	TIME	PRE-BMS-92	BMS-92	POST-BMS-92		
C-12-RC-1	12"	12" square columns; gravel aggregate concrete (2647 psi); Reinforcement: vertical, four 3/8" rebars; horizontal, 5/16" ties at 4 1/2" pitch; Cover: 2".	78.2 tons	38 min.		1	7	1	1/2
C-12-RC-2	12"	Reinforced columns with 1 1/2" concrete outside of reinforced steel; Gross diameter or side of column: 12"; Group I, Column A.	—	6 hrs.		1		2, 3	6
C-12-RC-3	12"	Description as per C-12-RC-2; Group I, Column B.	—	4 hrs.		1		2, 3	4
C-12-RC-4	12"	Description as per C-12-RC-2; Group II, Column A.	—	4 hrs.		1		2, 3	4
C-12-RC-5	12"	Description as per C-12-RC-2; Group II, Column B.	—	2 hrs. 30 min.		1		2, 3	2 1/2
C-12-RC-6	12"	Description as per C-12-RC-2; Group III, Column A.	—	3 hrs.		1		2, 3	3
C-12-RC-7	12"	Description as per C-12-RC-2; Group III, Column B.	—	2 hrs.		1		2, 3	2
C-12-RC-8	12"	Description as per C-12-RC-2; Group IV, Column A.	—	2 hrs.		1		2, 3	2
C-12-RC-9	12"	Description as per C-12-RC-2; Group IV, Column B.	—	1 hr. 30 min.		1		2, 3	1 1/2

Notes:

1. Failure mode - unspecified structural.
2. Group I: includes concrete having calcareous aggregate containing a combined total of not more than 10 percent of quartz, chert and flint for the coarse aggregate.
 Group II: includes concrete having trap-rock aggregate applied without metal ties and also concrete having cinder, sandstone or granite aggregate, if held in place with wire mesh or expanded metal having not larger than 4-inch mesh, weighing not less than 1.7 lbs./yd.², placed not more than 1 inch from the surface of the concrete.
 Group III: includes concrete having cinder, sandstone or granite aggregate tied with No. 5 gage steel wire, wound spirally over the column section on a pitch of 8 inches, or equivalent ties, and concrete having siliceous aggregates containing a combined total of 60 percent or more of quartz, chert and flint, if held in place with wire mesh or expanded metal having not larger than 4-inch mesh, weighing not less than 1.7 lbs./yd.², placed not more than 1 inch from the surface of the concrete.
 Group IV: includes concrete having siliceous aggregates containing a combined total of 60 percent or more of quartz, chert and flint, and tied with No. 5 gage steel wire wound spirally over the column section on a pitch of 8 inches, or equivalent ties.
3. Groupings of aggregates and ties are the same as for structural steel columns protected solidly with concrete, the ties to be placed over the vertical reinforcing bars and the mesh where required, to be placed within 1 inch from the surface of the column.
 Column A: working loads are assumed as carried by the area of the column inside of the lines circumscribing the reinforcing steel.
 Column B: working loads are assumed as carried by the gross area of the column.

**TABLE 2.1.4—REINFORCED CONCRETE COLUMNS
MINIMUM DIMENSION 14" TO LESS THAN 16"**

ITEM CODE	MINIMUM DIMENSION	CONSTRUCTION DETAILS	PERFORMANCE		REFERENCE NUMBER			NOTES	REC. HOURS
			LOAD	TIME	PRE-BMS-92	BMS-92	POST-BMS-92		
C-14-RC-1	14"	14" square columns; gravel aggregate concrete (4295 psi); Reinforcement: vertical four 3/4" rebars; horizontal: 1/4" ties at 9" pitch; Cover: 1 1/2".	86 tons	1 hr. 22 min.			7	1	1 1/4
C-14-RC-2	14"	Reinforced concrete columns with 1 1/2" concrete outside reinforcing steel; Gross diameter or side of column: 12"; Group I, Column A.	—	7 hrs.		1		2, 3	7
C-14-RC-3	14"	Description as per C-14-RC-2; Group II, Column B.	—	5 hrs.		1		2, 3	5
C-14-RC-4	14"	Description as per C-14-RC-2; Group III, Column A.	—	5 hrs.		1		2, 3	5
C-14-RC-5	14"	Description as per C-14-RC-2; Group IV, Column B.	—	3 hrs. 30 min.		1		2, 3	3 1/2
C-14-RC-6	14"	Description as per C-14-RC-2; Group III, Column A.	—	4 hrs.		1		2, 3	4
C-14-RC-7	14"	Description as per C-14-RC-2; Group III, Column B.	—	2 hrs. 30 min.		1		2, 3	2 1/2
C-14-RC-8	14"	Description as per C-14-RC-2; Group IV, Column A.	—	2 hrs. 30 min.		1		2, 3	2 1/2
C-14-RC-9	14"	Description as per C-14-RC-2; Group IV, Column B.	—	1 hr. 30 min.		1		2, 3	1 1/2

Notes:

1. Failure mode - main rebars buckled between links at various points.
2. Group I: includes concrete having calcareous aggregate containing a combined total of not more than 10 percent of quartz, chert and flint for the coarse aggregate.
 Group II: includes concrete having trap-rock aggregate applied without metal ties and also concrete having cinder, sandstone or granite aggregate, if held in place with wire mesh or expanded metal having not larger than 4-inch mesh, weighing not less than 1.7 lbs./yd.², placed not more than 1 inch from the surface of the concrete.
 Group III: includes concrete having cinder, sandstone or granite aggregate tied with No. 5 gage steel wire, wound spirally over the column section on a pitch of 8 inches, or equivalent ties, and concrete having siliceous aggregates containing a combined total of 60 percent or more of quartz, chert and flint, if held in place with wire mesh or expanded metal having not larger than 4-inch mesh, weighing not less than 1.7 lbs./yd.², placed not more than 1 inch from the surface of the concrete.
 Group IV: includes concrete having siliceous aggregates containing a combined total of 60 percent or more of quartz, chert and flint, and tied with No. 5 gage steel wire wound spirally over the column section on a pitch of 8 inches, or equivalent ties.
3. Groupings of aggregates and ties are the same as for structural steel columns protected solidly with concrete, the ties to be placed over the vertical reinforcing bars and the mesh where required, to be placed within 1 inch from the surface of the column.
 Column A: working loads are assumed as carried by the area of the column inside of the lines circumscribing the reinforcing steel.
 Column B: working loads are assumed as carried by the gross area of the column.

**FIGURE 2.1.5—REINFORCED CONCRETE COLUMNS
MINIMUM DIMENSION 16" TO LESS THAN 18"**

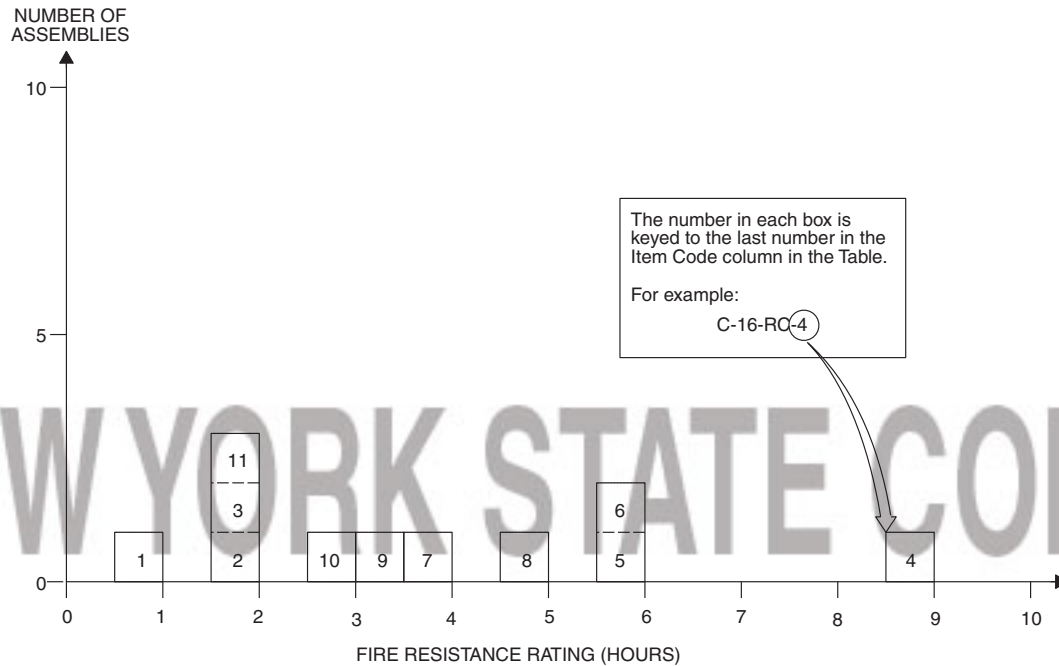

**TABLE 2.1.5—REINFORCED CONCRETE COLUMNS
MINIMUM DIMENSION 16" TO LESS THAN 18"**

ITEM CODE	MINIMUM DIMENSION	CONSTRUCTION DETAILS	PERFORMANCE		REFERENCE NUMBER			NOTES	REC. HOURS
			LOAD	TIME	PRE-BMS-92	BMS-92	POST-BMS-92		
C-16-RC-1	16"	16" square columns; gravel aggregate concrete (4550 psi); Reinforcement: vertical, eight 1 ³ / ₈ " rebars; horizontal, 5/16" ties at 6" pitch 1 ³ / ₈ " below column surface and 5/16" ties at 6" pitch linking center rebars of each face forming a smaller square in column cross section.	237 tons	1 hr			7	1, 2, 3	1
C-16-RC-2	16"	16" square columns; gravel aggregate concrete (3360 psi); Reinforcement: vertical, eight 1 ³ / ₈ " rebars; horizontal, 5/16" ties at 6" pitch; Cover: 1 ³ / ₈ ".	210 tons	2 hrs.			7	2, 4, 5, 6	2
C-16-RC-3	16"	16" square columns; gravel aggregate concrete (3980 psi); Reinforcement: vertical, four 7/8" rebars; horizontal, 3/8" ties at 6" pitch; Cover: 1".	123.5 tons	2 hrs.			7	2, 4, 7	2
C-16-RC-4	16"	Reinforced concrete columns with 1 ¹ / ₂ " concrete outside reinforcing steel; Gross diameter or side of column: 16"; Group I, Column A.	—	9 hrs.		1		8, 9	9
C-16-RC-5	16"	Description as per C-16-RC-4; Group I, Column B.	—	6 hrs.		1		8, 9	6

(Continued)

**TABLE 2.1.5—REINFORCED CONCRETE COLUMNS
MINIMUM DIMENSION 16" TO LESS THAN 18"—(Continued)**

ITEM CODE	MINIMUM DIMENSION	CONSTRUCTION DETAILS	PERFORMANCE		REFERENCE NUMBER			NOTES	REC. HOURS
			LOAD	TIME	PRE-BMS-92	BMS-92	POST-BMS-92		
C-16-RC-6	16"	Description as per C-16-RC-4; Group II, Column A.	—	6 hrs.		1		8, 9	6
C-16-RC-7	16"	Description as per C-16-RC-4; Group II, Column B.	—	4 hrs.		1		8, 9	4
C-16-RC-8	16"	Description as per C-16-RC-4; Group III, Column A.	—	5 hrs.		1		8, 9	5
C-16-RC-9	16"	Description as per C-16-RC-4; Group III, Column B.	—	3 hrs. 30 min.		1		8, 9	3½
C-16-RC-10	16"	Description as per C-16-RC-4; Group IV, Column A.	—	3 hrs.		1		8, 9	3
C-16-RC-11	16"	Description as per C-16-RC-4; Group IV, Column B.	—	2 hrs.		1		8, 9	2

Notes:

1. Column passed 1 hour fire test.
2. Column passed hose stream test.
3. No reload specified.
4. Column passed 2 hour fire test.
5. Column reloaded successfully after 24 hours.
6. Reinforcing details same as C-16-RC-1.
7. Column passed reload after 72 hours.
8. Group I: includes concrete having calcareous aggregate containing a combined total of not more than 10 percent of quartz, chert and flint for the coarse aggregate.
 Group II: includes concrete having trap-rock aggregate applied without metal ties and also concrete having cinder, sandstone or granite aggregate, if held in place with wire mesh or expanded metal having not larger than 4-inch mesh, weighing not less than 1.7 lbs./yd.², placed not more than 1 inch from the surface of the concrete.
 Group III: includes concrete having cinder, sandstone or granite aggregate tied with No. 5 gage steel wire, wound spirally over the column section on a pitch of 8 inches, or equivalent ties, and concrete having siliceous aggregates containing a combined total of 60 percent or more of quartz, chert and flint, if held in place with wire mesh or expanded metal having not larger than 4-inch mesh, weighing not less than 1.7 lbs./yd.², placed not more than 1 inch from the surface of the concrete.
 Group IV: includes concrete having siliceous aggregates containing a combined total of 60 percent or more of quartz, chert and flint, and tied with No. 5 gage steel wire wound spirally over the column section on a pitch of 8 inches, or equivalent ties.
9. Groupings of aggregates and ties are the same as for structural steel columns protected solidly with concrete, the ties to be placed over the vertical reinforcing bars and the mesh where required, to be placed within 1 inch from the surface of the column.
 Column A: working loads are assumed as carried by the area of the column inside of the lines circumscribing the reinforcing steel.
 Column B: working loads are assumed as carried by the gross area of the column.

COPYRIGHT® ICC 2005

**TABLE 2.1.6—REINFORCED CONCRETE COLUMNS
MINIMUM DIMENSION 18" TO LESS THAN 20"**

ITEM CODE	MINIMUM DIMENSION	CONSTRUCTION DETAILS	PERFORMANCE		REFERENCE NUMBER			NOTES	REC. HOURS
			LOAD	TIME	PRE-BMS-92	BMS-92	POST-BMS-92		
C-18-RC-1	18"	Reinforced concrete columns with 1½" concrete outside reinforced steel; Gross diameter or side of column: 18"; Group I, Column A.	—	11 hrs.		1		1, 2	11
C-18-RC-2	18"	Description as per C-18-RC-1; Group I, Column B.	—	8 hrs.		1		1, 2	8
C-18-RC-3	18"	Description as per C-18-RC-1; Group II, Column A.	—	7 hrs.		1		1, 2	7
C-18-RC-4	18"	Description as per C-18-RC-1; Group II, Column B.	—	5 hrs.		1		1, 2	5
C-18-RC-5	18"	Description as per C-18-RC-1; Group III, Column A.	—	6 hrs.		1		1, 2	6
C-18-RC-6	18"	Description as per C-18-RC-1; Group III, Column B.	—	4 hrs.		1		1, 2	4
C-18-RC-7	18"	Description as per C-18-RC-1; Group IV, Column A.	—	3 hrs. 30 min.		1		1, 2	3½
C-18-RC-8	18"	Description as per C-18-RC-1; Group IV, Column B.	—	2 hrs. 30 min.		1		1, 2	2½

Notes:

1. Group I: includes concrete having calcareous aggregate containing a combined total of not more than 10 percent of quartz, chert and flint for the coarse aggregate.
 Group II: includes concrete having trap-rock aggregate applied without metal ties and also concrete having cinder, sandstone or granite aggregate, if held in place with wire mesh or expanded metal having not larger than 4-inch mesh, weighing not less than 1.7 lbs./yd.², placed not more than 1 inch from the surface of the concrete.
 Group III: includes concrete having cinder, sandstone or granite aggregate tied with No. 5 gage steel wire, wound spirally over the column section on a pitch of 8 inches, or equivalent ties, and concrete having siliceous aggregates containing a combined total of 60 percent or more of quartz, chert and flint, if held in place with wire mesh or expanded metal having not larger than 4-inch mesh, weighing not less than 1.7 lbs./yd.², placed not more than 1 inch from the surface of the concrete.
 Group IV: includes concrete having siliceous aggregates containing a combined total of 60 percent or more of quartz, chert and flint and, tied with No. 5 gage steel wire wound spirally over the column section on a pitch of 8 inches, or equivalent ties.
2. Groupings of aggregates and ties are the same as for structural steel columns protected solidly with concrete, the ties to be placed over the vertical reinforcing bars and the mesh where required, to be placed within 1 inch from the surface of the column.
 Column A: working loads are assumed as carried by the area of the column inside of the lines circumscribing the reinforcing steel.
 Column B: working loads are assumed as carried by the gross area of the column.

COPYRIGHT® ICC 2005

**FIGURE 2.1.7—REINFORCED CONCRETE COLUMNS
MINIMUM DIMENSION 20" TO LESS THAN 22"**

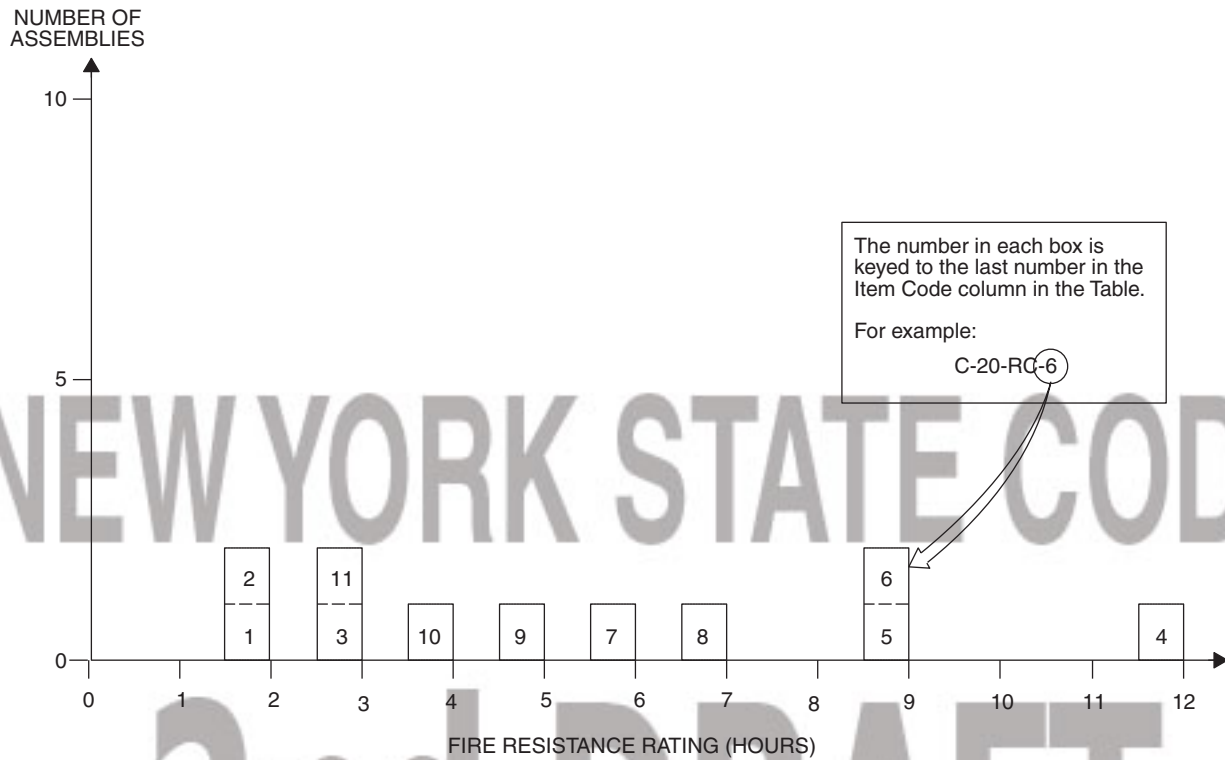

**TABLE 2.1.7—REINFORCED CONCRETE COLUMNS
MINIMUM DIMENSION 20" TO LESS THAN 22"**

ITEM CODE	MINIMUM DIMENSION	CONSTRUCTION DETAILS	PERFORMANCE		REFERENCE NUMBER			NOTES	REC. HOURS
			LOAD	TIME	PRE-BMS-92	BMS-92	POST-BMS-92		
C-20-RC-1	20"	20" square columns; gravel aggregate concrete (6690 psi); Reinforcement: vertical, four 1 ³ / ₄ " rebars; horizontal, 3 ³ / ₈ " wire at 6" pitch; Cover 1 ³ / ₄ ".	367 tons	2 hrs.			7	1, 2, 3	2
C-20-RC-2	20"	20" square columns; gravel aggregate concrete (4330 psi); Reinforcement: vertical, four 1 ³ / ₄ " rebars; horizontal, 3 ³ / ₈ " ties at 6" pitch; Cover 1 ³ / ₄ ".	327 tons	2 hrs.			7	1, 2, 4	2
C-20-RC-3	20 ¹ / ₄ "	20" square columns; gravel aggregate concrete (4230 psi); Reinforcement: vertical, four 1 ¹ / ₈ " rebars; horizontal, 3 ³ / ₈ " wire at 5" pitch; Cover 1 ¹ / ₈ ".	199 tons	2 hrs. 56 min.			7	5	2 ³ / ₄
C-20-RC-4	20"	Reinforced concrete columns with 1 ¹ / ₂ " concrete outside of reinforcing steel; Gross diameter or side of column: 20"; Group I, Column A.	—	12 hrs.		1		6, 7	12
C-20-RC-5	20"	Description as per C-20-RC-4; Group I, Column B.	—	9 hrs.		1		6, 7	9
C-20-RC-6	20"	Description as per C-20-RC-4; Group II, Column A.	—	9 hrs.		1		6, 7	9

(Continued)

**TABLE 2.1.7—REINFORCED CONCRETE COLUMNS
MINIMUM DIMENSION 20" TO LESS THAN 22"—(Continued)**

ITEM CODE	MINIMUM DIMENSION	CONSTRUCTION DETAILS	PERFORMANCE		REFERENCE NUMBER			NOTES	REC. HOURS
			LOAD	TIME	PRE-BMS-92	BMS-92	POST-BMS-92		
C-20-RC-7	20"	Description as per C-20-RC-4; Group II, Column B.	—	6 hrs		1		6, 7	6
C-20-RC-8	20"	Description as per C-20-RC-4; Group III, Column A.	—	7 hrs.		1		6, 7	7
C-20-RC-9	20"	Description as per C-20-RC-4; Group III, Column B.	—	5 hrs.		1		6, 7	5
C-20-RC-10	20"	Description as per C-20-RC-4; Group IV, Column A.	—	4 hrs.		1		6, 7	4
C-20-RC-11	20"	Description as per C-20-RC-4; Group IV, Column B.	—	3 hrs.		1		6, 7	3

Notes:

1. Passed 2 hour fire test.
2. Passed hose stream test.
3. Failed during reload at 300 tons.
4. Passed reload after 72 hours.
5. Failure mode - collapse.
6. Group I: includes concrete having calcareous aggregate containing a combined total of not more than 10 percent of quartz, chert and flint for the coarse aggregate.
Group II: includes concrete having trap-rock aggregate applied without metal ties and also concrete having cinder, sandstone or granite aggregate, if held in place with wire mesh or expanded metal having not larger than 4-inch mesh, weighing not less than 1.7 lbs./yd², placed not more than 1 inch from the surface of the concrete.
Group III: includes concrete having cinder, sandstone or granite aggregate tied with No. 5 gage steel wire, wound spirally over the column section on a pitch of 8 inches, or equivalent ties, and concrete having siliceous aggregates containing a combined total of 60 percent or more of quartz, chert and flint, if held in place with wire mesh or expanded metal having not larger than 4-inch mesh, weighing not less than 1.7 lbs./yd², placed not more than 1 inch from the surface of the concrete.
Group IV: includes concrete having siliceous aggregates containing a combined total of 60 percent or more of quartz, chert and flint, and tied with No. 5 gage steel wire wound spirally over the column section on a pitch of 8 inches, or equivalent ties.
7. Groupings of aggregates and ties are the same as for structural steel columns protected solidly with concrete, the ties to be placed over the vertical reinforcing bars and the mesh where required, to be placed within 1 inch from the surface of the column.
Column A: working loads are assumed as carried by the area of the column inside of the lines circumscribing the reinforcing steel.
Column B: working loads are assumed as carried by the gross area of the column.

**TABLE 2.1.8—HEXAGONAL REINFORCED CONCRETE COLUMNS
MINIMUM DIMENSION 12" TO LESS THAN 14"**

ITEM CODE	MINIMUM DIMENSION	CONSTRUCTION DETAILS	PERFORMANCE		REFERENCE NUMBER			NOTES	REC. HOURS
			LOAD	TIME	PRE-BMS-92	BMS-92	POST-BMS-92		
C-12-HRC-1	12"	12" hexagonal columns; gravel aggregate concrete (4420 psi); Reinforcement: vertical, eight 1/2" rebars; horizontal, 5/16" helical winding at 1 1/2" pitch; Cover: 1/2".	88 tons	58 min.			7	1	3/4
C-12-HRC-2	12"	12" hexagonal columns; gravel aggregate concrete (3460 psi); Reinforcement: vertical, eight 1/2" rebars; horizontal, 5/16" helical winding at 1 1/2" pitch; Cover: 1/2".	78.7 tons	1 hr.			7	2	1

Notes:

1. Failure mode - collapse.
2. Test stopped at 1 hour.

**TABLE 2.1.9—HEXAGONAL REINFORCED CONCRETE COLUMNS
MINIMUM DIMENSION 14" TO LESS THAN 16"**

ITEM CODE	MINIMUM DIMENSION	CONSTRUCTION DETAILS	PERFORMANCE		REFERENCE NUMBER			NOTES	REC. HOURS
			LOAD	TIME	PRE-BMS-92	BMS-92	POST-BMS-92		
C-14-HRC-1	14"	14" hexagonal columns; gravel aggregate concrete (4970 psi); Reinforcement: vertical, eight 1/2" rebars; horizontal, 5/16" helical winding on 2" pitch; Cover: 1/2".	90 tons	2 hrs.			7	1, 2, 3	2

Notes:

1. Withstood 2 hour fire test.
2. Withstood hose stream test.
3. Withstood reload after 48 hours.

**TABLE 2.1.10—HEXAGONAL REINFORCED CONCRETE COLUMNS
DIAMETER — 16" TO LESS THAN 18"**

ITEM CODE	MINIMUM DIMENSION	CONSTRUCTION DETAILS	PERFORMANCE		REFERENCE NUMBER			NOTES	REC. HOURS
			LOAD	TIME	PRE-BMS-92	BMS-92	POST-BMS-92		
C-16-HRC-1	16"	16" hexagonal columns; gravel concrete (6320 psi); Reinforcement: vertical, eight 5/8" rebars; horizontal, 5/16" helical winding on 3/4" pitch; Cover: 1/2".	140 tons	1 hr. 55 min.			7	1	1 3/4
C-16-HRC-2	16"	16" hexagonal columns; gravel aggregate concrete (5580 psi); Reinforcement: vertical, eight 5/8" rebars; horizontal, 5/16" helical winding on 1 3/4" pitch; Cover: 1/2"	124 tons	2 hrs.			7	2	2

Notes:

1. Failure mode - collapse.
2. Failed on furnace removal.

**TABLE 2.1.11—HEXAGONAL REINFORCED CONCRETE COLUMNS
DIAMETER — 20" TO LESS THAN 22"**

ITEM CODE	MINIMUM DIMENSION	CONSTRUCTION DETAILS	PERFORMANCE		REFERENCE NUMBER			NOTES	REC. HOURS
			LOAD	TIME	PRE-BMS-92	BMS-92	POST-BMS-92		
C-20-HRC-1	20"	20" hexagonal columns; gravel concrete (6080 psi); Reinforcement: vertical, 3/4" rebars; horizontal, 5/6" helical winding on 1 3/4" pitch; Cover: 1/2".	211 tons	2 hrs.			7	1	2
C-20-HRC-2	20"	20" hexagonal columns; gravel concrete (5080 psi); Reinforcement: vertical, 3/4" rebars; horizontal, 5/16" wire on 1 3/4" pitch; Cover: 1/2".	184 tons	2 hrs. 15 min.			7	2, 3, 4	2 1/4

Notes:

1. Column collapsed on furnace removal.
2. Passed 2 1/4 hour fire test.
3. Passed hose stream test.
4. Withstood reload after 48 hours.

TABLE 2.2—ROUND CAST IRON COLUMNS

ITEM CODE	MINIMUM DIMENSION	CONSTRUCTION DETAILS	PERFORMANCE		REFERENCE NUMBER			NOTES	REC. HOURS
			LOAD	TIME	PRE-BMS-92	BMS-92	POST-BMS-92		
C-7-CI-1	7" O.D.	Column: .6" minimum metal thickness; unprotected.	—	30 min.		1			1/2
C-7-CI-2	7" O.D.	Column: .6" minimum metal thickness concrete filled, outside unprotected.	—	45 min.		1			3/4
C-11-CI-3	11" O.D.	Column: .6" minimum metal thickness; Protection: 1 1/2" portland cement plaster on high ribbed metal lath, 1/2" broken air space.	—	3 hrs.		1			3
C-11-CI-4	11" O.D.	Column: .6" minimum metal thickness; Protection: 2" concrete other than siliceous aggregate.	—	2 hrs. 30 min.		1			2 1/2
C-12-CI-5	12.5" O.D.	Column: 7" O.D. .6" minimum metal thickness; Protection: 2" porous hollow tile, 3/4" mortar between tile and column, outside wire ties.	—	3 hrs.		1			3
C-7-CI-6	7.6" O.D.	Column: 7" I.D., 3/10" minimum metal thickness, concrete filled unprotected.	—	30 min.		1			1/2
C-8-CI-7	8.6" O.D.	Column: 8" I.D., 3/10" minimum metal thickness; concrete filled reinforced with four 3 1/2" x 3/8" angles, in fill; unprotected outside.	—	1 hr.		1			1

NEW YORK STATE CODE
2nd DRAFT

COPYRIGHT® ICC 2005

FIGURE 2.3—STEEL COLUMNS—GYPSUM ENCASEMENTS

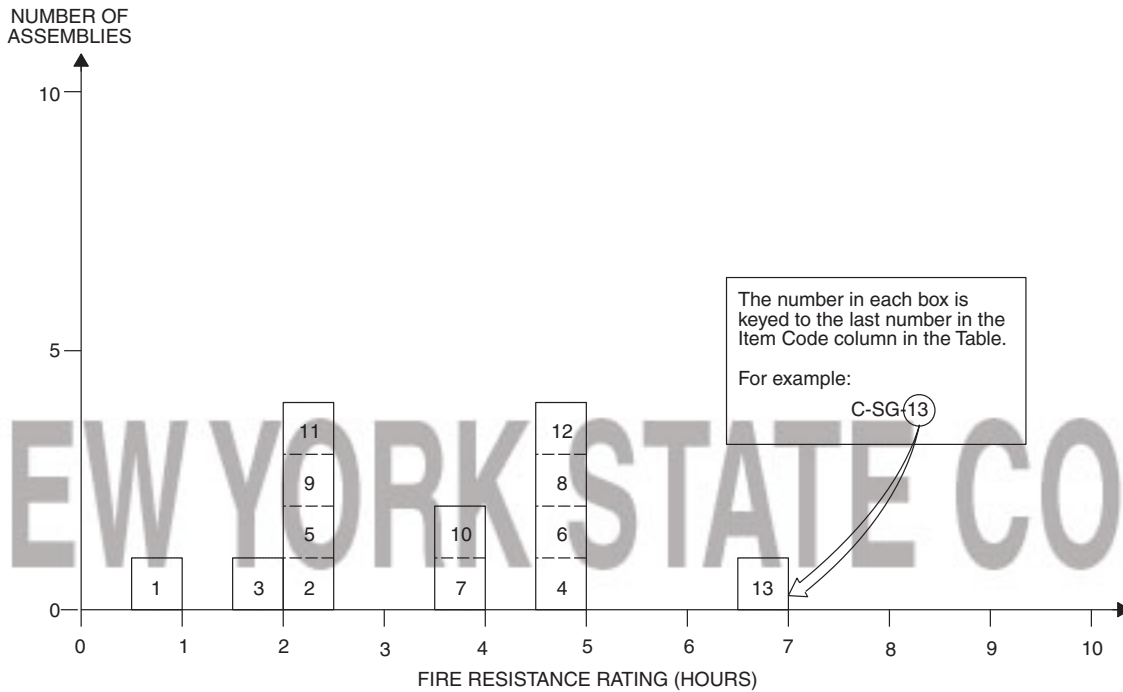

TABLE 2.3—STEEL COLUMNS—GYPSUM ENCASEMENTS

ITEM CODE	MINIMUM AREA OF SOLID MATERIAL	CONSTRUCTION DETAILS	PERFORMANCE		REFERENCE NUMBER			NOTES	REC. HOURS
			LOAD	TIME	PRE-BMS-92	BMS-92	POST-BMS-92		
C-SG-1	—	Steel protected with 3/4" 1:3 sanded gypsum or 1" 1:2 1/2 portland cement plaster on wire or lath; one layer.	—	1 hr.		1			1
C-SG-2	—	Same as C-SG-1; two layers.	—	2 hrs. 30 min.		1			2 1/2
C-SG-3	130 in. ²	2" solid blocks with wire mesh in horizontal joints; 1" mortar on flange; reentrant space filled with block and mortar.	—	2 hrs.		1			2
C-SG-4	150 in. ²	Same as C-130-SG-3 with 1/2" sanded gypsum plaster.	—	5 hrs.		1			5
C-SG-5	130 in. ²	2" solid blocks with wire mesh in horizontal joints; 1" mortar on flange; reentrant space filled with gypsum concrete.	—	2 hrs. 30 min.		1			2 1/2
C-SG-6	150 in. ²	Same as C-130-SG-5 with 1/2" sanded gypsum plaster.	—	5 hrs.		1			5
C-SG-7	300 in. ²	4" solid blocks with wire mesh in horizontal joints; 1" mortar on flange; reentrant space filled with block and mortar.	—	4 hrs.		1			4
C-SG-8	300 in. ²	Same as C-300-SG-7 with reentrant space filled with gypsum concrete.	—	5 hrs.		1			5

(Continued)

TABLE 2.3—STEEL COLUMNS—GYPSUM ENCASEMENTS—(Continued)

ITEM CODE	MINIMUM AREA OF SOLID MATERIAL	CONSTRUCTION DETAILS	PERFORMANCE		REFERENCE NUMBER			NOTES	REC. HOURS
			LOAD	TIME	PRE-BMS-92	BMS-92	POST-BMS-92		
C-SG-9	85 in. ²	2" solid blocks with cramps at horizontal joints; mortar on flange only at horizontal joints; reentrant space not filled.	—	2 hrs. 30 min.		1			2½
C-SG-10	105 in. ²	Same as C-85-SG-9 with ½" sanded gypsum plaster.	—	4 hrs.		1			4
C-SG-11	95 in. ²	3" hollow blocks with cramps at horizontal joints; mortar on flange only at horizontal joints; reentrant space not filled.	—	2 hrs. 30 min.		1			2½
C-SG-12	120 in. ²	Same as C-95-SG-11 with ½" sanded gypsum plaster.	—	5 hrs.		1			5
C-SG-13	130 in. ²	2" neat fibered gypsum reentrant space filled poured solid and reinforced with 4" × 4" wire mesh ½" sanded gypsum plaster.	—	7 hrs.		1			7

TABLE 2.4—TIMBER COLUMNS
MINIMUM DIMENSION

ITEM CODE	MINIMUM DIMENSION	CONSTRUCTION DETAILS	PERFORMANCE		REFERENCE NUMBER			NOTES	REC. HOURS
			LOAD	TIME	PRE-BMS-92	BMS-92	POST-BMS-92		
C-11-TC-1	11"	With unprotected steel plate cap.	—	30 min.		1		1, 2	½
C-11-TC-2	11"	With unprotected cast iron cap and pintle.	—	45 min.		1		1, 2	¾
C-11-TC-3	11"	With concrete or protected steel or cast iron cap.	—	1 hr. 15 min.		1		1, 2	1¼
C-11-TC-4	11"	With ¾" gypsum wallboard over column and over cast iron or steel cap.	—	1 hr. 15 min.		1		1, 2	1¼
C-11-TC-5	11"	With 1" portland cement plaster on wire lath over column and over cast iron or steel cap; ¾" air space.	—	2 hrs.		1		1, 2	2

Notes:

1. Minimum area: 120 square inches.
2. Type of wood: long leaf pine or Douglas fir.

TABLE 2.5.1.1—STEEL COLUMNS—CONCRETE ENCASEMENTS
MINIMUM DIMENSION LESS THAN 6"

ITEM CODE	MINIMUM DIMENSION	CONSTRUCTION DETAILS	PERFORMANCE		REFERENCE NUMBER			NOTES	REC. HOURS
			LOAD	TIME	PRE-BMS-92	BMS-92	POST-BMS-92		
C-5-SC-1	5"	5" × 6" outer dimensions; 4" × 3" × 10 lbs. "H" beam; Protection: gravel concrete (4900 psi) 6" × 4" - 13 SWG mesh.	12 tons	1 hr. 29 min.			7	1	1¼

Notes:

1. Failure mode - collapse.

**TABLE 2.5.1.2—STEEL COLUMNS—CONCRETE ENCASEMENTS
6" TO LESS THAN 8" THICK**

ITEM CODE	MINIMUM DIMENSION	CONSTRUCTION DETAILS	PERFORMANCE		REFERENCE NUMBER			NOTES	REC. HOURS
			LOAD	TIME	PRE-BMS-92	BMS-92	POST-BMS-92		
C-7-SC-1	7"	7" × 8" column; 4" × 3" × 10 lbs. "H" beam; Protection: brick filled concrete (6220 psi); 6" × 4" mesh - 13 SWG; 1" below column surface.	12 tons	2 hrs. 46 min.			7	1	3
C-7-SC-2	7"	7" × 8" column; 4" × 3" × 10 lbs. "H" beam; Protection: gravel concrete (5140 psi); 6" × 4" 13 SWG mesh 1" below surface.	12 tons	3 hrs. 1 min.			7	1	2 ³ / ₄
C-7-SC-3	7"	7" × 8" column; 4" × 3" × 10 lbs. "H" beam; Protection: concrete (4540 psi); 6" × 4" - 13 SWG mesh; 1" below column surface.	12 tons	3 hrs. 9 min.			7	1	3
C-7-SC-4	7"	7" × 8" column; 4" × 3" × 10 lbs. "H" beam; Protection: gravel concrete (5520 psi); 4" × 4" mesh; 16 SWG.	12 tons	2 hrs. 50 min.			7	1	2 ³ / ₄

Notes:

1. Failure mode - collapse.

2nd DRAFT

COPYRIGHT® ICC 2005

**FIGURE 2.5.1.3—STEEL COLUMNS—CONCRETE ENCASEMENTS
MINIMUM DIMENSION 8" TO LESS THAN 10"**

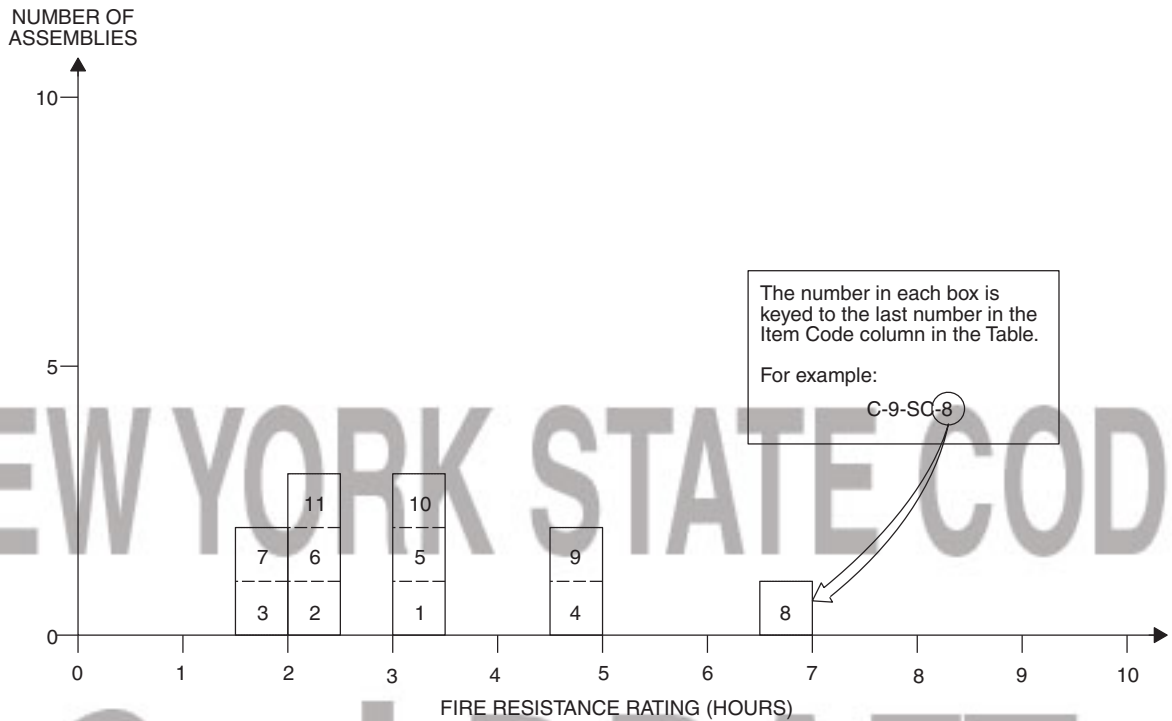

**TABLE 2.5.1.3—STEEL COLUMNS—CONCRETE ENCASEMENTS
MINIMUM DIMENSION 8" TO LESS THAN 10"**

ITEM CODE	MINIMUM DIMENSION	CONSTRUCTION DETAILS	PERFORMANCE		REFERENCE NUMBER			NOTES	REC. HOURS
			LOAD	TIME	PRE-BMS-92	BMS-92	POST-BMS-92		
C-8-SC-1	8½"	8½" × 10" column; 6" × 4½" × 20 lbs. "H" beam; Protection: gravel concrete (5140 psi); 6" × 4" - 13 SWG mesh.	39 tons	3 hrs. 8 min.			7	1	3
C-8-SC-2	8"	8" × 10" column; 8" × 6" × 35 lbs. "I" beam; Protection: gravel concrete (4240 psi); 6" × 4" - 13 SWG mesh; ½" cover.	90 tons	2 hrs. 1 min.			7	1	2
C-8-SC-3	8"	8" × 10" concrete encased column; 8" × 6" × 35 lbs. "H" beam; protection: aggregate concrete (3750 psi); 4" mesh - 16 SWG reinforcing ½" below column surface.	90 tons	1 hr. 58 min.			7	1	1¾
C-8-SC-4	8"	6" × 6" steel column; 2" outside protection; Group I.	—	5 hrs.		1		2	5
C-8-SC-5	8"	6" × 6" steel column; 2" outside protection; Group II.	—	3 hrs. 30 min.		1		2	3½
C-8-SC-6	8"	6" × 6" steel column; 2" outside protection; Group III.	—	2 hrs. 30 min.		1		2	2½
C-8-SC-7	8"	6" × 6" steel column; 2" outside protection; Group IV.	—	1 hr. 45 min.		1		2	1¾

(Continued)

**TABLE 2.5.1.3—STEEL COLUMNS—CONCRETE ENCASEMENTS
MINIMUM DIMENSION 8" TO LESS THAN 10"—(Continued)**

ITEM CODE	MINIMUM DIMENSION	CONSTRUCTION DETAILS	PERFORMANCE		REFERENCE NUMBER			NOTES	REC. HOURS
			LOAD	TIME	PRE-BMS-92	BMS-92	POST-BMS-92		
C-9-SC-8	9"	6" × 6" steel column; 3" outside protection; Group I.	—	7 hrs.		1		2	7
C-9-SC-9	9"	6" × 6" steel column; 3" outside protection; Group II.	—	5 hrs.		1		2	5
C-9-SC-10	9"	6" × 6" steel column; 3" outside protection; Group III.	—	3 hrs. 30 min.		1		2	3½
C-9-SC-11	9"	6" × 6" steel column; 3" outside protection; Group IV.	—	2 hrs. 30 min.		1		2	2½

Notes:

1. Failure mode - collapse.
2. Group I: includes concrete having calcareous aggregate containing a combined total of not more than 10 percent of quartz, chert and flint for the coarse aggregate.
Group II: includes concrete having trap-rock aggregate applied without metal ties and also concrete having cinder, sandstone or granite aggregate, if held in place with wire mesh or expanded metal having not larger than 4-inch mesh, weighing not less than 1.7 lbs./yd.², placed not more than 1 inch from the surface of the concrete.
Group III: includes concrete having cinder, sandstone or granite aggregate tied with No. 5 gage steel wire, wound spirally over the column section on a pitch of 8 inches, or equivalent ties, and concrete having siliceous aggregates containing a combined total of 60 percent or more of quartz, chert and flint, if held in place with wire mesh or expanded metal having not larger than 4-inch mesh, weighing not less than 1.7 lbs./yd.², placed not more than 1 inch from the surface of the concrete.
Group IV: includes concrete having siliceous aggregates containing a combined total of 60 percent or more of quartz, chert and flint, and tied with No. 5 gage steel wire wound spirally over the column section on a pitch of 8 inches, or equivalent ties.

2nd DRAFT

COPYRIGHT® ICC 2005

**FIGURE 2.5.1.4—STEEL COLUMNS—CONCRETE ENCASEMENTS
MINIMUM DIMENSION 10" TO LESS THAN 12"**

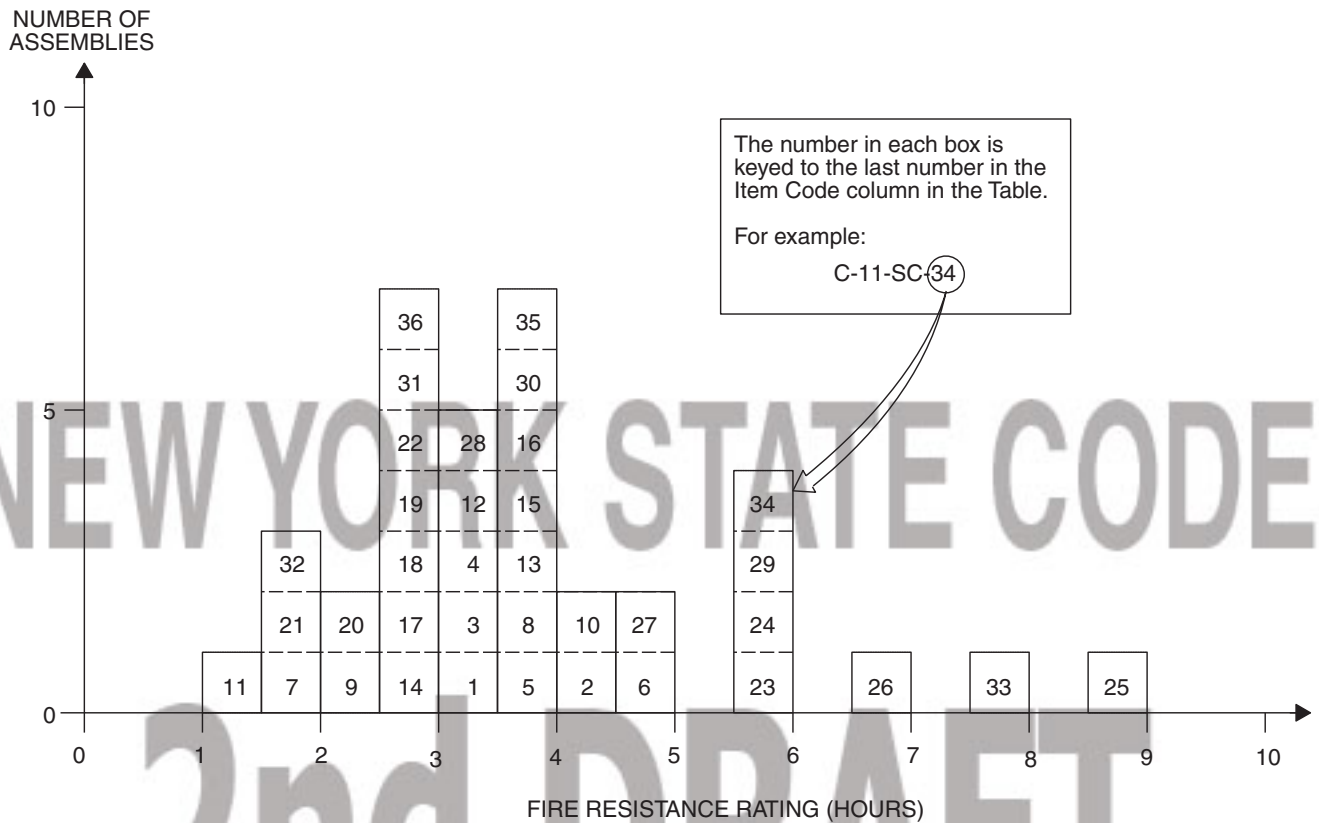

**TABLE 2.5.1.4—STEEL COLUMNS—CONCRETE ENCASEMENTS
MINIMUM DIMENSION 10" TO LESS THAN 12"**

ITEM CODE	MINIMUM DIMENSION	CONSTRUCTION DETAILS	PERFORMANCE		REFERENCE NUMBER			NOTES	REC. HOURS
			LOAD	TIME	PRE-BMS-92	BMS-92	POST-BMS-92		
C-10-SC-1	10"	10" × 12" concrete encased steel column; 8" × 6" × 35 lbs. "H" beam; Protection: gravel aggregate concrete (3640 psi); Mesh 6" × 4" 13 SWG, 1" below column surface.	90 tons	3 hrs. 7 min.			7	1,2	3
C-10-SC-2	10"	10" × 16" column; 8" × 6" × 35 lbs. "H" beam; Protection: clay brick concrete (3630 psi); 6" × 4" mesh; 13 SWG, 1" below column surface.	90 tons	4 hrs. 6 min.			7	2	4
C-10-SC-3	10"	10" × 12" column; 8" × 6" × 35 lbs. "H" beam; Protection: crushed stone and sand concrete (3930 psi); 6" × 4" - 13 SWG mesh; 1" below column surface.	90 tons	3 hrs. 17 min.			7	2	3¼
C-10-SC-4	10"	10" × 12" column; 8" × 6" × 35 lbs. "H" beam; Protection: crushed basalt and sand concrete (4350 psi); 6" × 4" - 13 SWG mesh; 1" below column surface.	90 tons	3 hrs. 22 min.			7	2	3⅓

(Continued)

**TABLE 2.5.1.4—STEEL COLUMNS—CONCRETE ENCASEMENTS
MINIMUM DIMENSION 10" TO LESS THAN 12"—(Continued)**

ITEM CODE	MINIMUM DIMENSION	CONSTRUCTION DETAILS	PERFORMANCE		REFERENCE NUMBER			NOTES	REC. HOURS
			LOAD	TIME	PRE-BMS-92	BMS-92	POST-BMS-92		
C-10-SC-5	10"	10" × 12" column; 8" × 6" × 35 lbs. "H" beam; Protection: gravel aggregate concrete (5570 psi); 6" × 4" mesh; 13 SWG.	90 tons	3 hrs. 39 min.			7	2	3½
C-10-SC-6	10"	10" × 16" column; 8" × 6" × 35 lbs. "T" beam; Protection: gravel concrete (4950 psi); mesh; 6" × 4" 13 SWG 1" below column surface.	90 tons	4 hrs. 32 min.			7	2	4½
C-10-SC-7	10"	10" × 12" concrete encased steel column; 8" × 6" × 35 lbs. "H" beam; Protection: aggregate concrete (1370 psi); 6" × 4" mesh; 13 SWG reinforcing 1" below column surface.	90 tons	2 hrs.			7	3, 4	2
C-10-SC-8	10"	10" × 12" concrete encased steel column; 8" × 6" × 35 lbs. "H" column; Protection: aggregate concrete (4000 psi); 13 SWG iron wire loosely around column at 6" pitch about 2" beneath column surface.	86 tons	3 hrs. 36 min.			7	2	3½
C-10-SC-9	10"	10" × 12" concrete encased steel column; 8" × 6" × 35 lbs. "H" beam; Protection: aggregate concrete (3290 psi); 2" cover minimum.	86 tons	2 hrs. 8 min.			7	2	2
C-10-SC-10	10"	10" × 14" concrete encased steel column; 8" × 6" × 35 lbs. "H" column; Protection: crushed brick filled concrete (5310 psi); 6" × 4" mesh; 13 SWG reinforcement 1" below column surface.	90 tons	4 hrs. 28 min.			7	2	4⅓
C-10-SC-11	10"	10" × 14" concrete encased column; 8" × 6" 35 lbs. "H" beam; Protection: aggregate concrete (342 psi); 6" × 4" mesh; 13 SWG reinforcement 1" below surface.	90 tons	1 hr. 2 min.			7	2	1
C-10-SC-12	10"	10" × 12" concrete encased steel column; 8" × 6" × 35 lbs. "H" beam; Protection: aggregate concrete (4480 psi); four 3/8" vertical bars at "H" beam edges with 3/16" spacers at beam surface at 3' pitch and 3/16" binders at 10" pitch; 2" concrete cover.	90 tons	3 hrs. 2 min.			7	2	3

(Continued)

**TABLE 2.5.1.4—STEEL COLUMNS—CONCRETE ENCASEMENTS
MINIMUM DIMENSION 10" TO LESS THAN 12"—(Continued)**

ITEM CODE	MINIMUM DIMENSION	CONSTRUCTION DETAILS	PERFORMANCE		REFERENCE NUMBER			NOTES	REC. HOURS
			LOAD	TIME	PRE-BMS-92	BMS-92	POST-BMS-92		
C-10-SC-13	10"	10" × 12" concrete encased steel column; 8" × 6" × 35 lbs. "H" beam; Protection: aggregate concrete (5070 psi); 6" × 4" mesh; 13 SWG reinforcing at 6" beam sides wrapped and held by wire ties across (open) 8" beam face; reinforcements wrapped in 6" × 4" mesh; 13 SWG throughout; 1/2" cover to column surface.	90 tons	3 hrs. 59 min.			7	2	3 ³ / ₄
C-10-SC-14	10"	10" × 12" concrete encased steel column; 8" × 6" × 35 lbs. "H" beam; Protection: aggregate concrete (4410 psi); 6" × 4" mesh; 13 SWG reinforcement 1 ¹ / ₄ " below column surface; 1/2" limestone cement plaster with 3/8" gypsum plaster finish.	90 tons	2 hrs. 50 min.			7	2	2 ³ / ₄
C-10-SC-15	10"	10" × 12" concrete encased steel column; 8" × 6" × 35 lbs. "H" beam; Protection: crushed clay brick filled concrete (4260 psi); 6" × 4" mesh; 13 SWG reinforcing 1" below column surface.	90 tons	3 hrs. 54 min.			7	2	3 ³ / ₄
C-10-SC-16	10"	10" × 12" concrete encased steel column; 8" × 6" × 35 lbs. "H" beam; Protection: limestone aggregate concrete (4350 psi); 6" × 4" mesh; 13 SWG reinforcing 1" below column surface.	90 tons	3 hrs. 54 min.			7	2	3 ³ / ₄
C-10-SC-17	10"	10" × 12" concrete encased steel column; 8" × 6" × 35 lbs. "H" beam; Protection: limestone aggregate concrete (5300 psi); 6" × 4"; 13 SWG wire mesh 1" below column surface.	90 tons	3 hrs.			7	4, 5	3
C-10-SC-18	10"	10" × 12" concrete encased steel column; 8" × 6" × 35 lbs. "H" beam; Protection: limestone aggregate concrete (4800 psi) with 6" × 4"; 13 SWG mesh reinforcement 1" below surface.	90 tons	3 hrs.			7	4, 5	3
C-10-SC-19	10"	10" × 14" concrete encased steel column; 12" × 8" × 65 lbs. "H" beam; Protection: aggregate concrete (3900 psi); 4" mesh; 16 SWG reinforcing 1/2" below column surface.	118 tons	2 hrs. 42 min.			7	2	2
C-10-SC-20	10"	10" × 14" concrete encased steel column; 12" × 8" × 65 lbs. "H" beam; Protection: aggregate concrete (4930 psi); 4" mesh; 16 SWG reinforcing 1/2" below column surface.	177 tons	2 hrs. 8 min.			7	2	2

(Continued)

**TABLE 2.5.1.4—STEEL COLUMNS—CONCRETE ENCASEMENTS
MINIMUM DIMENSION 10" TO LESS THAN 12"—(Continued)**

ITEM CODE	MINIMUM DIMENSION	CONSTRUCTION DETAILS	PERFORMANCE		REFERENCE NUMBER			NOTES	REC. HOURS
			LOAD	TIME	PRE-BMS-92	BMS-92	POST-BMS-92		
C-10-SC-21	10 ³ / ₈ "	10 ³ / ₈ " × 12 ³ / ₈ " concrete encased steel column; 8" × 6" × 35 lbs. "H" beam; Protection: aggregate concrete (835 psi) with 6" × 4" mesh; 13 SWG reinforcing 1 ³ / ₁₆ " below column surface; 3/16" gypsum plaster finish.	90 tons	2 hrs.			7	3, 4	2
C-11-SC-22	11"	11" × 13" concrete encased steel column; 8" × 6" × 35 lbs. "H" beam; Protection: "open texture" brick filled concrete (890 psi) with 6" × 4" mesh; 13 SWG reinforcing 1 ¹ / ₂ " below column surface; 3/8" lime cement plaster; 1/8" gypsum plaster finish.	90 tons	3 hrs.			7	6, 7	3
C-11-SC-23	11"	11" × 12" column; 4" × 3" × 10 lbs. "H" beam; gravel concrete (4550 psi); 6" × 4" - 13 SWG mesh reinforcing; 1" below column surface.	12 tons	6 hrs.			7	7, 8	6
C-11-SC-24	11"	11" × 12" column; 4" × 3" × 10 lbs. "H" beam; Protection: gravel aggregate concrete (3830 psi); with 4" × 4" mesh; 16 SWG, 1" below column surface.	16 tons	5 hrs. 32 min.			7	2	5 ¹ / ₂
C-10-SC-25	10"	6" × 6" steel column with 4" outside protection; Group I.	—	9 hrs.		1		9	9
C-10-SC-26	10"	Description as per C-SC-25; Group II.	—	7 hrs.		1		9	7
C-10-SC-27	10"	Description as per C-10-SC-25; Group III.	—	5 hrs.		1		9	5
C-10-SC-28	10"	Description as per C-10-SC-25; Group IV.	—	3 hrs. 30 min.		1		9	3 ¹ / ₂
C-10-SC-29	10"	8" × 8" steel column with 2" outside protection; Group I.	—	6 hrs.		1		9	6
C-10-SC-30	10"	Description as per C-10-SC-29; Group II.	—	4 hrs.		1		9	4
C-10-SC-31	10"	Description as per C-10-SC-29; Group III.	—	3 hrs.		1		9	3
C-10-SC-32	10"	Description as per C-10-SC-29; Group IV.	—	2 hrs.		1		9	2
C-11-SC-33	11"	8" × 8" steel column with 3" outside protection; Group I.	—	8 hrs.		1		9	8
C-11-SC-34	11"	Description as per C-10-SC-33; Group II.	—	6 hrs.		1		9	6
C-11-SC-35	11"	Description as per C-10-SC-33; Group III.	—	4 hrs.		1		9	4

(Continued)

**TABLE 2.5.1.4—STEEL COLUMNS—CONCRETE ENCASEMENTS
MINIMUM DIMENSION 10" TO LESS THAN 12"—(Continued)**

ITEM CODE	MINIMUM DIMENSION	CONSTRUCTION DETAILS	PERFORMANCE		REFERENCE NUMBER			NOTES	REC. HOURS
			LOAD	TIME	PRE-BMS-92	BMS-92	POST-BMS-92		
C-11-SC-36	11"	Description as per C-10-SC-33; Group IV.	—	3 hrs.		1		9	3

Notes:

1. Tested under total restraint load to prevent expansion - minimum load 90 tons.
2. Failure mode - collapse.
3. Passed 2 hour fire test (Grade "C," British).
4. Passed hose stream test.
5. Column tested and passed 3 hour grade fire resistance (British).
6. Column passed 3 hour fire test.
7. Column collapsed during hose stream testing.
8. Column passed 6 hour fire test.
9. Group I: includes concrete having calcareous aggregate containing a combined total of not more than 10 percent of quartz, chert and flint for the coarse aggregate.
- Group II: includes concrete having trap-rock aggregate applied without metal ties and also concrete having cinder, sandstone or granite aggregate, if held in place with wire mesh or expanded metal having not larger than 4-inch mesh, weighing not less than 1.7 lbs./yd.², placed not more than 1 inch from the surface of the concrete.
- Group III: includes concrete having cinder, sandstone or granite aggregate tied with No. 5 gage steel wire, wound spirally over the column section on a pitch of 8 inches, or equivalent ties, and concrete having siliceous aggregates containing a combined total of 60 percent or more of quartz, chert and flint, if held in place with wire mesh or expanded metal having not larger than 4-inch mesh, weighing not less than 1.7 lbs./yd.², placed not more than 1 inch from the surface of the concrete.
- Group IV: includes concrete having siliceous aggregates containing a combined total of 60 percent or more of quartz, chert and flint, and tied with No. 5 gage steel wire wound spirally over the column section on a pitch of 8 inches, or equivalent ties.

2nd DRAFT

COPYRIGHT® ICC 2005

**FIGURE 2.5.1.5—STEEL COLUMNS—CONCRETE ENCASEMENTS
MINIMUM DIMENSION 12" TO LESS THAN 14"**

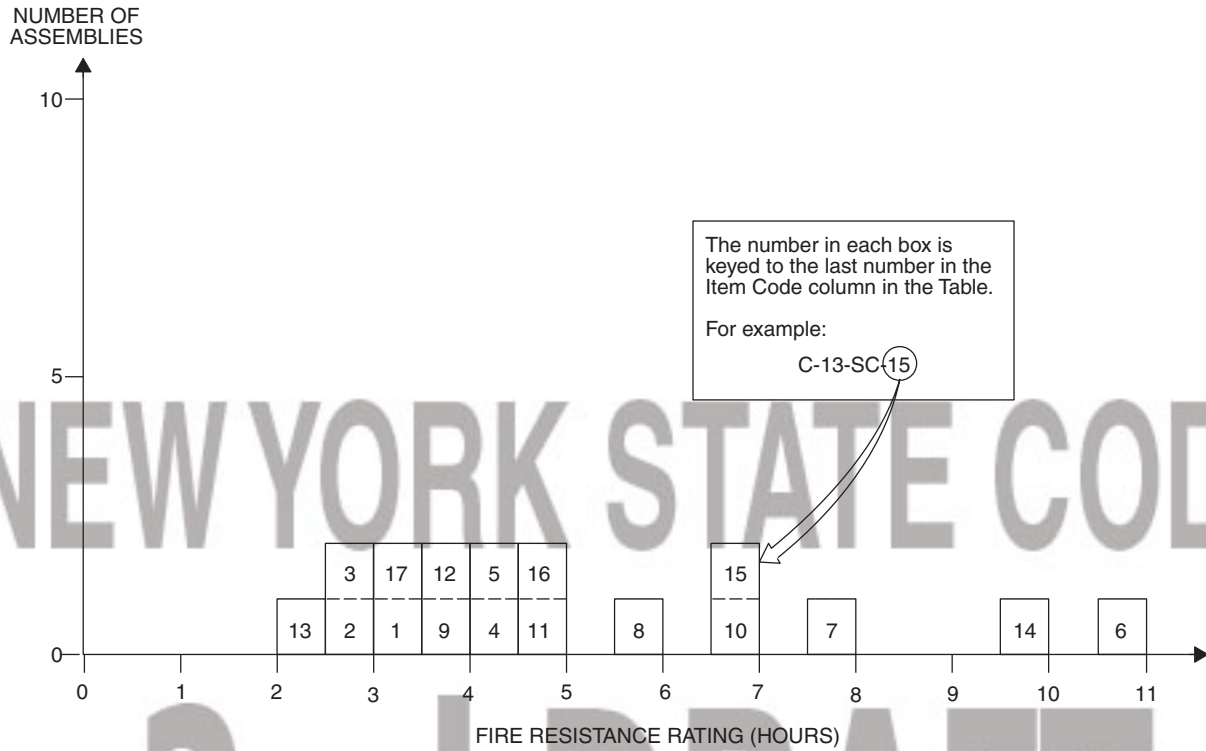

**TABLE 2.5.1.5—STEEL COLUMNS—CONCRETE ENCASEMENTS
MINIMUM DIMENSION 12" TO LESS THAN 14"**

ITEM CODE	MINIMUM DIMENSION	CONSTRUCTION DETAILS	PERFORMANCE		REFERENCE NUMBER			NOTES	REC. HOURS
			LOAD	TIME	PRE-BMS-92	BMS-92	POST-BMS-92		
C-12-SC-1	12"	12" × 14" concrete encased steel column; 8" × 6" × 35 lbs. "H" beam; Protection: aggregate concrete (4150 psi) with 4" mesh; 16 SWG reinforcing 1" below column surface.	120 tons	3 hrs. 24 min.			7	1	3 ¹ / ₃
C-12-SC-2	12"	12" × 16" concrete encased column; 8" × 6" × 35 lbs. "H" beam; Protection: aggregate concrete (4300 psi) with 4" mesh; 16 SWG reinforcing 1" below column surface.	90 tons	2 hrs. 52 min.			7	1	2 ³ / ₄
C-12-SC-3	12"	12" × 16" concrete encased steel column; 12" × 8" × 65 lbs. "H" column; Protection: gravel aggregate concrete (3550 psi) with 4" mesh; 16 SWG reinforcement 1" below column surface.	177 tons	2 hrs. 31 min.			7	1	2 ¹ / ₂
C-12-SC-4	12"	12" × 16" concrete encased column; 12" × 8" × 65 lbs. "H" beam; Protection: aggregate concrete (3450 psi) with 4" mesh; 16 SWG reinforcement 1" below column surface.	118 tons	4 hrs. 4 min.			7	1	4

(Continued)

**TABLE 2.5.1.5—STEEL COLUMNS—CONCRETE ENCASEMENTS
MINIMUM DIMENSION 12" TO LESS THAN 14"—(Continued)**

ITEM CODE	MINIMUM DIMENSION	CONSTRUCTION DETAILS	PERFORMANCE		REFERENCE NUMBER			NOTES	REC. HOURS
			LOAD	TIME	PRE-BMS-92	BMS-92	POST-BMS-92		
C-12-SC-5	12½"	12½" × 14" column; 6" × 4½" × 20 lbs. "H" beam; Protection: gravel aggregate concrete (3750 psi) with 4" × 4" mesh; 16 SWG reinforcing 1" below column surface.	52 tons	4 hrs. 29 min.			7	1	4⅓
C-12-SC-6	12"	8" × 8" steel column; 2" outside protection; Group I.	—	11 hrs.			1	2	11
C-12-SC-7	12"	Description as per C-12-SC-6; Group II.	—	8 hrs.		1		2	8
C-12-SC-8	12"	Description as per C-12-SC-6; Group III.	—	6 hrs.		1		2	6
C-12-SC-9	12"	Description as per C-12-SC-6; Group IV.	—	4 hrs.		1		2	4
C-12-SC-10	12"	10" × 10" steel column; 2" outside protection; Group I.	—	7 hrs.		1		2	7
C-12-SC-11	12"	Description as per C-12-SC-10; Group II.	—	5 hrs.		1		2	5
C-12-SC-12	12"	Description as per C-12-SC-10; Group III.	—	4 hrs.		1		2	4
C-12-SC-13	12"	Description as per C-12-SC-10; Group IV.	—	2 hrs. 30 min.		1		2	2½
C-13-SC-14	13"	10" × 10" steel column; 3" outside protection; Group I.	—	10 hrs.		1		2	10
C-13-SC-15	13"	Description as per C-12-SC-14; Group II.	—	7 hrs.		1		2	7
C-13-SC-16	13"	Description as per C-12-SC-14; Group III.	—	5 hrs.		1		2	5
C-13-SC-17	13"	Description as per C-12-SC-14; Group IV.	—	3 hrs. 30 min.		1		2	3½

Notes:

1. Failure mode - collapse.
2. Group I: includes concrete having calcareous aggregate containing a combined total of not more than 10 percent of quartz, chert and flint for the coarse aggregate.
- Group II: includes concrete having trap-rock aggregate applied without metal ties and also concrete having cinder, sandstone or granite aggregate, if held in place with wire mesh or expanded metal having not larger than 4-inch mesh, weighing not less than 1.7 lbs./yd.², placed not more than 1 inch from the surface of the concrete.
- Group III: includes concrete having cinder, sandstone or granite aggregate tied with No. 5 gage steel wire, wound spirally over the column section on a pitch of 8 inches, or equivalent ties, and concrete having siliceous aggregates containing a combined total of 60 percent or more of quartz, chert and flint, if held in place with wire mesh or expanded metal having not larger than 4-inch mesh, weighing not less than 1.7 lbs./yd.², placed not more than 1 inch from the surface of the concrete.
- Group IV: includes concrete having siliceous aggregates containing a combined total of 60 percent or more of quartz, chert and flint, and tied with No. 5 gage steel wire wound spirally over the column section on a pitch of 8 inches, or equivalent ties.

**FIGURE 2.5.1.6—STEEL COLUMNS—CONCRETE ENCASEMENTS
MINIMUM DIMENSION 14" TO LESS THAN 16"**

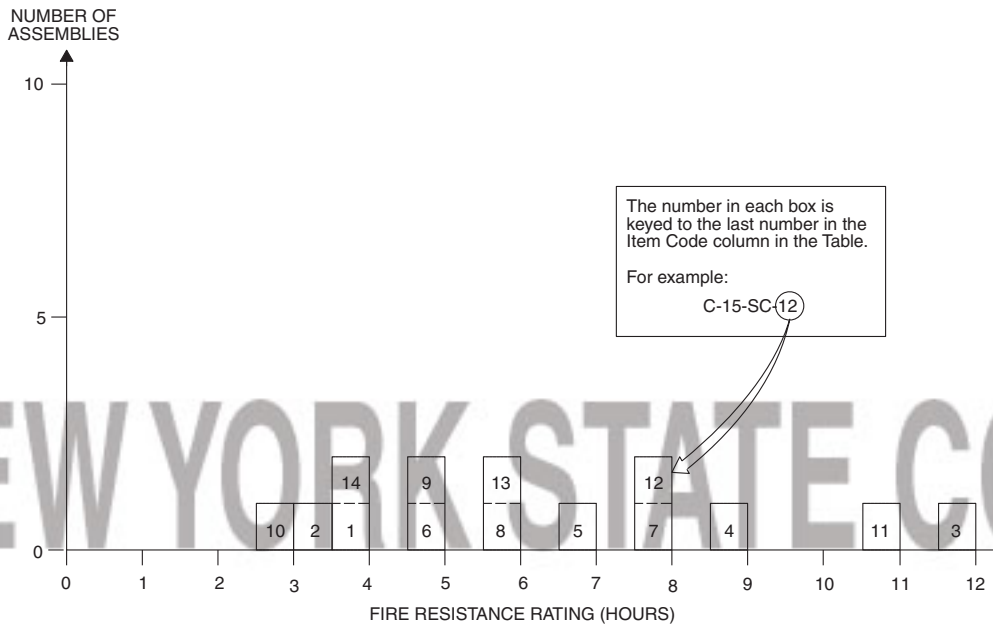

**TABLE 2.5.1.6—STEEL COLUMNS—CONCRETE ENCASEMENTS
MINIMUM DIMENSION 14" TO LESS THAN 16"**

ITEM CODE	MINIMUM DIMENSION	CONSTRUCTION DETAILS	PERFORMANCE		REFERENCE NUMBER			NOTES	REC. HOURS
			LOAD	TIME	PRE-BMS-92	BMS-92	POST-BMS-92		
C-14-SC-1	14"	24" × 16" concrete encased steel column; 8" × 6" × 35 lbs. "H" column; Protection: aggregate concrete (4240 psi); 4" mesh - 16 SWG reinforcing 1" below column surface.	90 tons	3 hrs. 40 min.			7	1	3
C-14-SC-2	14"	14" × 18" concrete encased steel column; 12" × 8" × 65 lbs. "H" beam; Protection: gravel aggregate concrete (4000 psi) with 4" - 16 SWG wire mesh reinforcement 1" below column surface.	177 tons	3 hrs. 20 min.			7	1	3
C-14-SC-3	14"	10" × 10" steel column; 4" outside protection; Group I.	—	12 hrs.		1		2	12
C-14-SC-4	14"	Description as per C-14-SC-3; Group II.	—	9 hrs.		1		2	9
C-14-SC-5	14"	Description as per C-14-SC-3; Group III.	—	7 hrs.		1		2	7
C-14-SC-6	14"	Description as per C-14-SC-3; Group IV.	—	5 hrs.		1		2	5
C-14-SC-7	14"	12" × 12" steel column; 2" outside protection; Group I.	—	8 hrs.		1		2	8
C-14-SC-8	14"	Description as per C-14-SC-7; Group II.	—	6 hrs.		1		2	6

(Continued)

**TABLE 2.5.1.6—STEEL COLUMNS—CONCRETE ENCASEMENTS
MINIMUM DIMENSION 14" TO LESS THAN 16"—(Continued)**

ITEM CODE	MINIMUM DIMENSION	CONSTRUCTION DETAILS	PERFORMANCE		REFERENCE NUMBER			NOTES	REC. HOURS
			LOAD	TIME	PRE-BMS-92	BMS-92	POST-BMS-92		
C-14-SC-9	14"	Description as per C-14-SC-7; Group III.	—	5 hrs.		1		2	5
C-14-SC-10	14"	Description as per C-14-SC-7; Group IV	—	3 hrs.		1		2	3
C-15-SC-11	15"	12" × 12" steel column; 3" outside protection; Group I.	—	11 hrs.		1		2	11
C-15-SC-12	15"	Description as per C-15-SC-11; Group II.	—	8 hrs.		1		2	8
C-15-SC-13	15"	Description as per C-15-SC-11; Group III.	—	6 hrs.		1		2	6
C-15-SC-14	15"	Description as per C-15-SC-11; Group IV.	—	4 hrs.		1		2	4

Notes:

1. Collapse.
2. Group I: includes concrete having calcareous aggregate containing a combined total of not more than 10 percent of quartz, chert and flint for the coarse aggregate.
Group II: includes concrete having trap-rock aggregate applied without metal ties and also concrete having cinder, sandstone or granite aggregate, if held in place with wire mesh or expanded metal having not larger than 4-inch mesh, weighing not less than 1.7 lbs./yd.², placed not more than 1 inch from the surface of the concrete.
Group III: includes concrete having cinder, sandstone or granite aggregate tied with No. 5 gage steel wire, wound spirally over the column section on a pitch of 8 inches, or equivalent ties, and concrete having siliceous aggregates containing a combined total of 60 percent or more of quartz, chert and flint, if held in place with wire mesh or expanded metal having not larger than 4-inch mesh, weighing not less than 1.7 lbs./yd.², placed not more than 1 inch from the surface of the concrete.
Group IV: includes concrete having siliceous aggregates containing a combined total of 60 percent or more of quartz, chert and flint, and tied with No. 5 gage steel wire wound spirally over the column section on a pitch of 8 inches, or equivalent ties.

**TABLE 2.5.1.7—STEEL COLUMNS—CONCRETE ENCASEMENTS
MINIMUM DIMENSION 16" TO LESS THAN 18"**

ITEM CODE	MINIMUM DIMENSION	CONSTRUCTION DETAILS	PERFORMANCE		REFERENCE NUMBER			NOTES	REC. HOURS
			LOAD	TIME	PRE-BMS-92	BMS-92	POST-BMS-92		
C-16-SC-13	16"	12" × 12" steel column; 4" outside protection; Group I.	—	14 hrs.		1		1	14
C-16-SC-2	16"	Description as per C-16-SC-1; Group II.	—	10 hrs.		1		1	10
C-16-SC-3	16"	Description as per C-16-SC-1; Group III.	—	8 hrs.		1		1	8
C-16-SC-4	16"	Description as per C-16-SC-1; Group IV.	—	5 hrs.		1		1	5

Notes:

1. Group I: includes concrete having calcareous aggregate containing a combined total of not more than 10 percent of quartz, chert and flint for the coarse aggregate.
Group II: includes concrete having trap-rock aggregate applied without metal ties and also concrete having cinder, sandstone or granite aggregate, if held in place with wire mesh or expanded metal having not larger than 4-inch mesh, weighing not less than 1.7 lbs./yd.², placed not more than 1 inch from the surface of the concrete.
Group III: includes concrete having cinder, sandstone or granite aggregate tied with No. 5 gage steel wire, wound spirally over the column section on a pitch of 8 inches, or equivalent ties, and concrete having siliceous aggregates containing a combined total of 60 percent or more of quartz, chert and flint, if held in place with wire mesh or expanded metal having not larger than 4-inch mesh, weighing not less than 1.7 lbs./yd.², placed not more than 1 inch from the surface of the concrete.
Group IV: includes concrete having siliceous aggregates containing a combined total of 60 percent or more of quartz, chert and flint, and tied with No. 5 gage steel wire wound spirally over the column section on a pitch of 8 inches, or equivalent ties.

**TABLE 2.5.2.1—STEEL COLUMNS—BRICK AND BLOCK ENCASEMENTS
MINIMUM DIMENSION 10" TO LESS THAN 12"**

ITEM CODE	MINIMUM DIMENSION	CONSTRUCTION DETAILS	PERFORMANCE		REFERENCE NUMBER			NOTES	REC. HOURS
			LOAD	TIME	PRE-BMS-92	BMS-92	POST-BMS-92		
C-10-SB-1	10½"	10½" × 13" brick encased steel columns; 8" × 6" × 35 lbs. "H" beam; Protection. Fill of broken brick and mortar; 2" brick on edge; joints broken in alternate courses; cement-sand grout; 13 SWG wire reinforcement in every third horizontal joint.	90 tons	3 hrs. 6 min.			7	1	3
C-10-SB-2	10½"	10½" × 13" brick encased steel columns; 8" × 6" × 35 lbs. "H" beam; Protection: 2" brick; joints broken in alternate courses; cement-sand grout; 13 SWG iron wire reinforcement in alternate horizontal joints.	90 tons	2 hrs.			7	2, 3, 4	2
C-10-SB-3	10"	10" × 12" block encased columns; 8" × 6" × 35 lbs. "H" beam; Protection: 2" foamed slag concrete blocks; 13 SWG wire at each horizontal joint; mortar at each joint.	90 tons	2 hrs.			7	5	2
C-10-SB-4	10½"	10½" × 12" block encased steel columns; 8" × 6" × 35 lbs. "H" beam; Protection: gravel aggregate concrete fill (unconsolidated) 2" thick hollow clay tiles with mortar at edges.	86 tons	56 min.			7	1	¾
C-10-SB-5	10½"	10½" × 12" block encased steel columns; 8" × 6" × 35 lbs. "H" beam; Protection: 2" hollow clay tiles with mortar at edges.	86 tons	22 min.			7	1	¼

Notes:

1. Failure mode - collapse.
2. Passed 2 hour fire test (Grade "C" - British).
3. Passed hose stream test.
4. Passed reload test.
5. Passed 2 hour fire exposure but collapsed immediately following hose stream test.

**TABLE 2.5.2.2—STEEL COLUMNS—BRICK AND BLOCK ENCASEMENTS
MINIMUM DIMENSION 12" TO LESS THAN 14"**

ITEM CODE	MINIMUM DIMENSION	CONSTRUCTION DETAILS	PERFORMANCE		REFERENCE NUMBER			NOTES	REC. HOURS
			LOAD	TIME	PRE-BMS-92	BMS-92	POST-BMS-92		
C-12-SB-1	12"	12" × 15" brick encased steel columns; 8" × 6" × 35 lbs. "H" beam; Protection: 2⅝" thick brick; joints broken in alternate courses; cement-sand grout; fill of broken brick and mortar.	90 tons	1 hr. 49 min.			7	1	1¾

Notes:

1. Failure mode – collapse.

**TABLE 2.5.2.3—STEEL COLUMNS—BRICK AND BLOCK ENCASEMENTS
MINIMUM DIMENSION 14" TO LESS THAN 16"**

ITEM CODE	MINIMUM DIMENSION	CONSTRUCTION DETAILS	PERFORMANCE		REFERENCE NUMBER			NOTES	REC. HOURS
			LOAD	TIME	PRE-BMS-92	BMS-92	POST-BMS-92		
C-15-SB-1	15"	15" × 17" brick encased steel columns; 8" × 6" × 35 lbs. "H" beam; Protection: 4½" thick brick; joints broken in alternate courses; cement-sand grout; fill of broken brick and mortar.	45 tons	6 hrs.			7	1	6
C-15-SB-2	15"	15" × 17" brick encased steel columns; 8" × 6" × 35 lbs. "H" beam; Protection. Fill of broken brick and mortar; 4½" brick; joints broken in alternate courses; cement-sand grout.	86 tons	6 hrs.			7	2, 3, 4	6
C-15-SB-3	15"	15" × 18" brick encased steel columns; 8" × 6" × 35 lbs. "H" beam; Protection: 4½" brick work; joints alternating; cement-sand grout.	90 tons	4 hrs.			7	5, 6	4
C-15-SB-4	14"	14" × 16" block encased steel columns; 8" × 6" × 35 lbs. "H" beam; Protection: 4" thick foam slag concrete blocks; 13 SWG wire reinforcement in each horizontal joint; mortar in joints.	90 tons	5 hrs. 52 min.			7	7	4¾

Notes:

1. Only a nominal load was applied to specimen.
2. Passed 6 hour fire test (Grade "A" - British).
3. Passed (6 minute) hose stream test.
4. Reload not specified.
5. Passed 4 hour fire exposure.
6. Failed by collapse between first and second minute of hose stream exposure.
7. Mode of failure - collapse.

**TABLE 2.5.3.1—STEEL COLUMNS—PLASTER ENCASEMENTS
MINIMUM DIMENSION 6" TO LESS THAN 8"**

ITEM CODE	MINIMUM DIMENSION	CONSTRUCTION DETAILS	PERFORMANCE		REFERENCE NUMBER			NOTES	REC. HOURS
			LOAD	TIME	PRE-BMS-92	BMS-92	POST-BMS-92		
C-7-SP-1	7½"	7½" × 9½" plaster protected steel columns; 8" × 6" × 35 lbs. "H" beam; Protection: 24 SWG wire metal lath; 1¼" lime plaster.	90 tons	57 min.			7	1	¾
C-7-SP-2	7⅞"	7⅞" × 10" plaster protected steel columns; 8" × 6" × 35 lbs. "H" beam; Protection: ⅜" gypsum bal wire wound with 16 SWG wire helically wound at 4" pitch; ½" gypsum plaster.	90 tons	1 hr. 13 min.			7	1	1
C-7-SP-3	7¼"	7¼" × 9⅜" plaster protected steel columns; 8" × 6" × 35 lbs. "H" beam; Protection: ⅜" gypsum board; wire helically wound 16 SWG at 4" pitch; ¼" gypsum plaster finish.	90 tons	1 hr. 14 min.			7	1	1

Notes:

1. Failure mode – collapse.

**TABLE 2.5.3.2—STEEL COLUMNS—PLASTER ENCASEMENTS
MINIMUM DIMENSION 8" TO LESS THAN 10"**

ITEM CODE	MINIMUM DIMENSION	CONSTRUCTION DETAILS	PERFORMANCE		REFERENCE NUMBER			NOTES	REC. HOURS
			LOAD	TIME	PRE-BMS-92	BMS-92	POST-BMS-92		
C-8-SP-1	8"	8" × 10" plaster protected steel columns; 8" × 6" × 35 lbs. "H" beam; Protection: 24 SWG wire lath; 1" gypsum plaster.	86 tons	1 hr. 23 min.			7	1	1 ¹ / ₄
C-8-SP-2	8 ¹ / ₂ "	8 ¹ / ₂ " × 10 ¹ / ₂ " plaster protected steel columns; 8" × 6" × 35 lbs. "H" beam; Protection: 24 SWG metal lath wrap; 1 ¹ / ₄ " gypsum plaster.	90 tons	1 hr. 36 min.			7	1	1 ¹ / ₂
C-9-SP-3	9"	9" × 11" plaster protected steel columns; 8" × 6" × 35 lbs. "H" beam; Protection: 24 SWG metal lath wrap; 1 ¹ / ₈ " M.S. ties at 12" pitch wire netting 1 ¹ / ₂ " × 22 SWG between first and second plaster coats; 1 ¹ / ₂ " gypsum plaster.	90 tons	1 hr. 33 min.			7	1	1 ¹ / ₂
C-8-SP-4	8 ³ / ₄ "	8 ³ / ₄ " × 10 ³ / ₄ " plaster protected steel columns; 8" × 6" × 35 lbs. "H" beam; Protection: 3 ¹ / ₄ " gypsum board; wire wound spirally (#16 SWG) at 1 ¹ / ₂ " pitch; 1 ¹ / ₂ " gypsum plaster.	90 tons	2 hrs.			7	2, 3, 4	2

Notes:

1. Failure mode - collapse.
2. Passed 2 hour fire exposure test (Grade "C" - British).
3. Passed hose stream test.
4. Passed reload test.

**TABLE 2.5.4.1—STEEL COLUMNS—MISCELLANEOUS ENCASEMENTS
MINIMUM DIMENSION 6" TO LESS THAN 8"**

ITEM CODE	MINIMUM DIMENSION	CONSTRUCTION DETAILS	PERFORMANCE		REFERENCE NUMBER			NOTES	REC. HOURS
			LOAD	TIME	PRE-BMS-92	BMS-92	POST-BMS-92		
C-7-SM-1	7 ⁵ / ₈ "	7 ⁵ / ₈ " × 9 ¹ / ₂ " (asbestos plaster) protected steel columns; 8" × 6" × 35 lbs. "H" beam; Protection: 20 gage 1 ¹ / ₂ " metal lath; 9 ¹ / ₁₆ " asbestos plaster (minimum).	90 tons	1 hr. 52 min.			7	1	1 ³ / ₄

Notes:

1. Failure mode - collapse.

**TABLE 2.5.4.2—STEEL COLUMNS—MISCELLANEOUS ENCASEMENTS
MINIMUM DIMENSION 8" TO LESS THAN 10"**

ITEM CODE	MINIMUM DIMENSION	CONSTRUCTION DETAILS	PERFORMANCE		REFERENCE NUMBER			NOTES	REC. HOURS
			LOAD	TIME	PRE-BMS-92	BMS-92	POST-BMS-92		
C-9-SM-1	9 ⁵ / ₈ "	9 ⁵ / ₈ " × 11 ³ / ₈ " asbestos slab and cement plaster protected columns; 8" × 6" × 35 lbs. "H" beam; Protection: 1" asbestos slab; wire wound; 5 ⁵ / ₈ " plaster.	90 tons	2 hrs.			7	1, 2	2

Notes:

1. Passed 2 hour fire exposure test.
2. Collapsed during hose stream test.

**TABLE 2.5.4.3—STEEL COLUMNS—MISCELLANEOUS ENCASEMENTS
MINIMUM DIMENSION 10" TO LESS THAN 12"**

ITEM CODE	MINIMUM DIMENSION	CONSTRUCTION DETAILS	PERFORMANCE		REFERENCE NUMBER			NOTES	REC. HOURS
			LOAD	TIME	PRE-BMS-92	BMS-92	POST-BMS-92		
C-11-SM-1	11½"	11½" × 13½" wood wool and plaster protected steel columns; 8" × 6" × 35 lbs. "H" beam; Protection: wood-wool-cement paste as fill and to 2" cover over beam; ¾" gypsum plaster finish.	90 tons	2 hrs.			7	1, 2, 3	2
C-10-SM-1	10"	10" × 12" asbestos protected steel columns; 8" × 6" × 35 lbs. "H" beam; Protection: sprayed on asbestos paste to 2" cover over column.	90 tons	4 hrs.			7	2, 3, 4	4

Notes:

1. Passed 2 hour fire exposure (Grade "C" - British).
2. Passed hose stream test.
3. Passed reload test.
4. Passed 4 hour fire exposure test.

**TABLE 2.5.4.4—STEEL COLUMNS—MISCELLANEOUS ENCASEMENTS
MINIMUM DIMENSION 12" TO LESS THAN 14"**

ITEM CODE	MINIMUM DIMENSION	CONSTRUCTION DETAILS	PERFORMANCE		REFERENCE NUMBER			NOTES	REC. HOURS
			LOAD	TIME	PRE-BMS-92	BMS-92	POST-BMS-92		
C-12-SM-1	12"	12" × 14¼" cement and asbestos protected columns; 8" × 6" × 35 lbs. "H" beam; Protection: fill of asbestos packing pieces 1" thick 1' 3" o.c.; cover of 2" molded asbestos inner layer; 1" molded asbestos outer layer; held in position by 16 SWG nichrome wire ties; wash of refractory cement on outer surface.	86 tons	4 hrs. 43 min.			7	1, 2, 3	4 ² / ₃

Notes:

1. Passed 4 hour fire exposure (Grade "B" - British).
2. Passed hose stream test.
3. Passed reload test.

SECTION III—FLOOR/CEILING ASSEMBLIES

FIGURE 3.1—FLOOR/CEILING ASSEMBLIES—REINFORCED CONCRETE

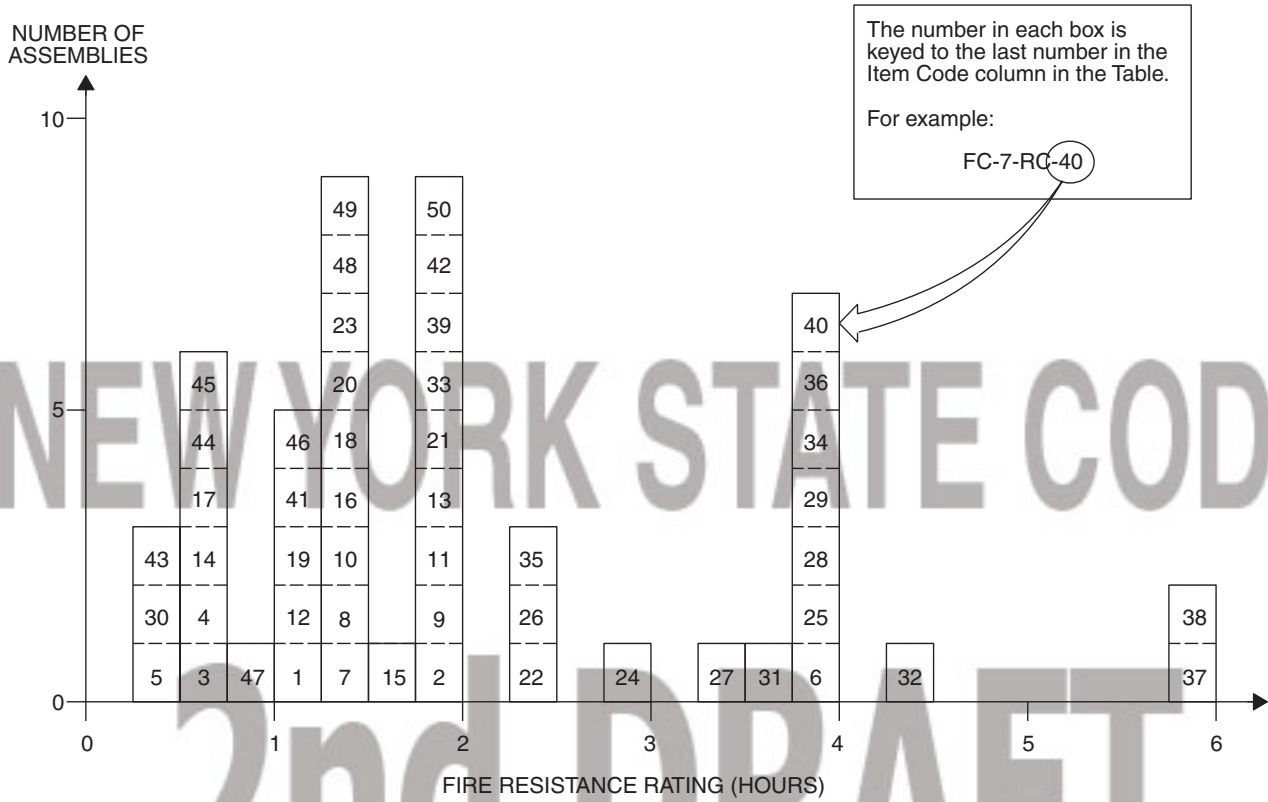

TABLE 3.1—FLOOR/CEILING ASSEMBLIES—REINFORCED CONCRETE

ITEM CODE	ASSEMBLY THICKNESS	CONSTRUCTION DETAILS	PERFORMANCE		REFERENCE NUMBER			NOTES	REC. HOURS
			LOAD	TIME	PRE-BMS-92	BMS-92	POST-BMS-92		
F/C-3-RC-1	3 ³ / ₄ "	3 ³ / ₄ " thick floor; 3 ¹ / ₄ " (5475 psi) concrete deck; 1/2" plaster under deck; 3/8" main reinforcement bars at 5 ¹ / ₂ " pitch with 7/8" concrete cover; 3/8" main reinforcement bars at 4 ¹ / ₂ " pitch perpendicular with 1/2" concrete cover; 13'1" span restrained.	195 psf	24 min.			7	1, 2	1
F/C-3-RC-2	3 ¹ / ₄ "	3 ¹ / ₄ " deep (3540 psi) concrete deck; 3/8" main reinforcement bars at 5 ¹ / ₂ " pitch with 7/8" cover; 3/8" main reinforcement bars at 4 ¹ / ₂ " pitch perpendicular with 1/2" cover; 13'1" span restrained.	195 psf	2 hrs.			7	1, 3, 4	1 ³ / ₄
F/C-3-RC-3	3 ¹ / ₄ "	3 ¹ / ₄ " deep (4175 psi) concrete deck; 3/8" main reinforcement bars at 5 ¹ / ₂ " pitch with 7/8" cover; 3/8" main reinforcement bars at 4 ¹ / ₂ " pitch perpendicular with 1/2" cover; 13'1" span restrained.	195 psf	31 min.			7	1, 5	1/2

(Continued)

TABLE 3.1—FLOOR/CEILING ASSEMBLIES—REINFORCED CONCRETE—(Continued)

ITEM CODE	ASSEMBLY THICKNESS	CONSTRUCTION DETAILS	PERFORMANCE		REFERENCE NUMBER			NOTES	REC. HOURS
			LOAD	TIME	PRE-BMS-92	BMS-92	POST-BMS-92		
F/C-3-RC-4	3 1/4"	3 1/4" deep (4355 psi) concrete deck; 3/8" main reinforcement bars at 5 1/2" pitch with 7/8" cover; 3/8" main reinforcement bars at 4 1/2" pitch perpendicular with 1/2" cover; 13'1" span restrained.	195 psf	41 min.			7	1, 5, 6	1/2
F/C-3-RC-5	3 1/4"	3 1/4" thick (3800 psi) concrete deck; 3/8" main reinforcement bars at 5 1/2" pitch with 7/8" cover; 3/8" main reinforcement bars at 4 1/2" pitch perpendicular with 1/2" cover; 13'1" span restrained.	195 psf	1 hr. 5 min.			7	1, 5	1/4
F/C-4-RC-6	4 1/4"	4 1/4" thick; 3 1/4" (4000 psi) concrete deck; 1" sprayed asbestos lower surface; 3/8" main reinforcement bars at 5 7/8" pitch with 7/8" concrete cover; 3/8" main reinforcement bars at 4 1/2" pitch perpendicular with 1/2" concrete cover; 13'1" span restrained.	195 psf	4 hrs.			7	1, 7	4
F/C-4-RC-7	4"	4" (5025 psi) concrete deck; 1/4" reinforcement bars at 7 1/2" pitch with 3/4" cover; 3/8" main reinforcement bars at 3 3/4" pitch perpendicular with 1/2" cover; 13'1" span restrained.	140 psf	1 hr. 16 min.			7	1, 2	1 1/4
F/C-4-RC-8	4"	4" thick (4905 psi) deck; 1/4" reinforcement bars at 7 1/2" pitch with 7/8" cover; 3/8" main reinforcement bars at 3 3/4" pitch perpendicular with 1/2" cover; 13'1" span restrained.	100 psf	1 hr. 23 min.			7	1, 2	1 1/3
F/C-4-RC-9	4"	4" deep (4370 psi); 1/4" reinforcement bars at 6" pitch with 3/4" cover; 1/4" main reinforcement bars at 4" pitch perpendicular with 1/2" cover; 13'1" span restrained.	150 psf	2 hrs.			7	1, 3	2
F/C-4-RC-10	4"	4" thick (5140 psi) deck; 1/4" reinforcement bars at 7 1/2" pitch with 7/8" cover; 3/8" main reinforcement bars at 3 3/4" pitch perpendicular with 1/2" cover; 13'1" span restrained.	140 psf	1 hr. 16 min.			7	1, 5	1 1/4
F/C-4-RC-11	4"	4" thick (4000 psi) concrete deck; 3" x 1 1/2" x 4 lbs. R.S.J.; 2'6" C.R.S.; flush with top surface; 4" x 6" x 13 SWG mesh reinforcement 1" from bottom of slab; 6'6" span restrained.	150 psf	2 hrs.			7	1, 3	2
F/C-4-RC-12	4"	4" deep (2380 psi) concrete deck; 3" x 1 1/2" x 4 lbs. R.S.J.; 2'6" C.R.S.; flush with top surface; 4" x 6" x 13 SWG mesh reinforcement 1" from bottom surface; 6'6" span restrained.	150 psf	1 hr. 3 min.			7	1, 2	1

(Continued)

TABLE 3.1—FLOOR/CEILING ASSEMBLIES—REINFORCED CONCRETE—(Continued)

ITEM CODE	ASSEMBLY THICKNESS	CONSTRUCTION DETAILS	PERFORMANCE		REFERENCE NUMBER			NOTES	REC. HOURS
			LOAD	TIME	PRE-BMS-92	BMS-92	POST-BMS-92		
F/C-4-RC-13	4 1/2"	4 1/2" thick (5200 psi) deck; 1/4" reinforcement bars at 7 1/4" pitch with 7/8" cover; 3/8" main reinforcement bars at 3 3/4" pitch perpendicular with 1/2" cover; 13'1" span restrained.	140 psf	2 hrs.			7	1, 3	2
F/C-4-RC-14	4 1/2"	4 1/2" deep (2525 psi) concrete deck; 1/4" reinforcement bars at 7 1/2" pitch with 7/8" cover; 3/8" main reinforcement bars at 3 3/8" pitch perpendicular with 1/2" cover; 13'1" span restrained.	150 psf	42 min.			7	1, 5	2/3
F/C-4-RC-15	4 1/2"	4 1/2" deep (4830 psi) concrete deck; 1 1/2" x No. 15 gauge wire mesh; 3/8" reinforcement bars at 15" pitch with 1" cover; 1/2" main reinforcement bars at 6" pitch perpendicular with 1/2" cover; 12' span simply supported.	75 psf	1 hr. 32 min.			7	1, 8	1 1/2
F/C-4-RC-16	4 1/2"	4 1/2" deep (4595 psi) concrete deck; 1/4" reinforcement bars at 7 1/2" pitch with 7/8" cover; 3/8" main reinforcement bars at 3 1/2" pitch perpendicular with 1/2" cover; 12' span simply supported.	75 psf	1 hr. 20 min.			7	1, 8	1 1/3
F/C-4-RC-17	4 1/2"	4 1/2" deep (3625 psi) concrete deck; 1/4" reinforcement bars at 7 1/2" pitch with 7/8" cover; 3/8" main reinforcement bars at 3 1/2" pitch perpendicular with 1/2" cover; 12' span simply supported.	75 psf	35 min.			7	1, 8	1/2
F/C-4-RC-18	4 1/2"	4 1/2" deep (4410 psi) concrete deck; 1/4" reinforcement bars at 7 1/2" pitch with 7/8" cover; 3/8" main reinforcement bars at 3 1/2" pitch perpendicular with 1/2" cover; 12' span simply supported.	85 psf	1 hr. 27 min.			7	1, 8	1 1/3
F/C-4-RC-19	4 1/2"	4 1/2" deep (4850 psi) deck; 3/8" reinforcement bars at 15" pitch with 1" cover; 1/2" main reinforcement bars at 6" pitch perpendicular with 1/2" cover; 12' span simply supported.	75 psf	2 hrs. 15 min.			7	1, 9	1 1/4
F/C-4-RC-20	4 1/2"	4 1/2" deep (3610 psi) deck; 1/4" reinforcement bars at 7 1/2" pitch with 7/8" cover; 3/8" main reinforcement bars at 3 1/2" pitch perpendicular with 1/2" cover; 12' span simply supported.	75 psf	1 hr. 22 min.			7	1, 8	1 1/3
F/C-5-RC-21	5"	5" deep; 4 1/2" (5830 psi) concrete deck; 1/2" plaster finish bottom of slab; 1/4" reinforcement bars at 7 1/2" pitch with 7/8" cover; 3/8" main reinforcement bars at 3 1/2" pitch perpendicular with 1/2" cover; 12' span simply supported.	69 psf	2 hrs.			7	1, 3	2

(Continued)

TABLE 3.1—FLOOR/CEILING ASSEMBLIES—REINFORCED CONCRETE—(Continued)

ITEM CODE	ASSEMBLY THICKNESS	CONSTRUCTION DETAILS	PERFORMANCE		REFERENCE NUMBER			NOTES	REC. HOURS
			LOAD	TIME	PRE-BMS-92	BMS-92	POST-BMS-92		
F/C-5-RC-22	5"	4½" (5290 psi) concrete deck; ½" plaster finish bottom of slab; ¼" reinforcement bars at 7½" pitch with ⅞" cover; ⅜" main reinforcement bars at 3½" pitch perpendicular with ½" cover; 12' span simply supported.	No load	2 hrs. 28 min.			7	1, 10, 11	2¼
F/C-5-RC-23	5"	5" (3020 psi) concrete deck; 3" × 1½" × 4 lbs. R.S.J.; 2' C.R.S. with 1" cover on bottom and top flanges; 8' span restrained.	172 psf	1 hr. 24 min.			7	1, 2, 12	1½
F/C-5-RC-24	5½"	5" (5180 psi) concrete deck; ½" retarded plaster underneath slab; ¼" reinforcement bars at 7½" pitch with 1⅜" cover; ⅜" main reinforcement bars at 3½" pitch perpendicular with 1" cover; 12' span simply supported.	60 psf	2 hrs. 48 min.			7	1, 10	2¾
F/C-6-RC-25	6"	6" deep (4800 psi) concrete deck; ¼" reinforcement bars at 7½" pitch with ⅞" cover; ⅜" main reinforcement bars at 3½" pitch perpendicular with ⅞" cover; 13'1" span restrained.	195 psf	4 hrs.			7	1, 7	4
F/C-6-RC-26	6"	6" (4650 psi) concrete deck; ¼" reinforcement bars at 7½" pitch with ⅞" cover; ⅜" main reinforcement bars at 3½" pitch perpendicular with ½" cover; 13'1" span restrained.	195 psf	2 hrs. 23 min.			7	1, 2	2¼
F/C-6-RC-27	6"	6" deep (6050 psi) concrete deck; ¼" reinforcement bars at 7½" pitch ⅞" cover; ⅜" reinforcement bars at 3½" pitch perpendicular with ½" cover; 13'1" span restrained.	195 psf	3 hrs. 30 min.			7	1, 10	3½
F/C-6-RC-28	6"	6" deep (5180 psi) concrete deck; ¼" reinforcement bars at 8" pitch ¾" cover; ¼" reinforcement bars at 5½" pitch perpendicular with ½" cover; 13'1" span restrained.	150 psf	4 hrs.			7	1, 7	4
F/C-6-RC-29	6"	6" thick (4180 psi) concrete deck; 4" × 3" × 10 lbs. R.S.J.; 2'6" C.R.S. with 1" cover on both top and bottom flanges; 13'1" span restrained.	160 psf	3 hrs. 48 min.			7	1, 10	3¾
F/C-6-RC-30	6"	6" thick (3720 psi) concrete deck; 4" × 3" × 10 lbs. R.S.J.; 2'6" C.R.S. with 1" cover on both top and bottom flanges; 12' span simply supported.	115 psf	29 min.			7	1, 5, 13	¼
F/C-6-RC-31	6"	6" deep (3450 psi) concrete deck; 4" × 1¾" × 5 lbs. R.S.J.; 2'6" C.R.S. with 1" cover on both top and bottom flanges; 12' span simply supported.	25 psf	3 hrs. 35 min.			7	1, 2	3½

(Continued)

TABLE 3.1—FLOOR/CEILING ASSEMBLIES—REINFORCED CONCRETE—(Continued)

ITEM CODE	ASSEMBLY THICKNESS	CONSTRUCTION DETAILS	PERFORMANCE		REFERENCE NUMBER			NOTES	REC. HOURS
			LOAD	TIME	PRE-BMS-92	BMS-92	POST-BMS-92		
F/C-6-RC-32	6"	6" deep (4460 psi) concrete deck; 4" × 1 ³ / ₄ " × 5 lbs. R.S.J.; 2' C.R.S.; with 1" cover on both top and bottom flanges; 12' span simply supported.	60 psf	4 hrs. 30 min.			7	1, 10	4 ¹ / ₂
F/C-6-RC-33	6"	6" deep (4360 psi) concrete deck; 4" × 1 ³ / ₄ " × 5 lbs. R.S.J.; 2' C.R.S.; with 1" cover on both top and bottom flanges; 13'1" span restrained.	60 psf	2 hrs.			7	1, 3	2
F/C-6-RC-34	6 ¹ / ₄ "	6 ¹ / ₄ " thick; 4 ³ / ₄ " (5120 psi) concrete core; 1" T&G board flooring; ¹ / ₂ " plaster undercoat; 4" × 3" × 10 lbs. R.S.J.; 3' C.R.S. flush with top surface concrete; 12' span simply supported; 2" × 1'3" clinker concrete insert.	100 psf	4 hrs.			7	1, 7	4
F/C-6-RC-35	6 ¹ / ₄ "	4 ³ / ₄ " (3600 psi) concrete core; 1" T&G board flooring; ¹ / ₂ " plaster undercoat; 4" × 3" × 10 lbs. R.S.J.; 3' C.R.S.; flush with top surface concrete; 12' span simply supported; 2" × 1'3" clinker concrete insert.	100 psf	2 hrs. 30 min.			7	1, 5	2 ¹ / ₂
F/C-6-RC-36	6 ¹ / ₄ "	4 ³ / ₄ " (2800 psi) concrete core; 1" T&G board flooring; ¹ / ₂ " plaster undercoat; 4" × 3" × 10 lbs. R.S.J.; 3' C.R.S.; flush with top surface concrete; 12" span simply supported; 2" × 1'3" clinker concrete insert.	80 psf	4 hrs.			7	1, 7	4
F/C-7-RC-37	7"	(3640 psi) concrete deck; ¹ / ₄ " reinforcement bars at 6" pitch with 1 ¹ / ₂ " cover; ¹ / ₄ " reinforcement bars at 5" pitch perpendicular with 1 ¹ / ₂ " cover; 13'1" span restrained.	169 psf	6 hrs.			7	1, 14	6
F/C-7-RC-38	7"	(4060 psi) concrete deck; 4" × 3" × 10 lbs. R.S.J.; 2'6" C.R.S. with 1 ¹ / ₂ " cover on both top and bottom flanges; 4" × 6" × 13 SWG mesh reinforcement 1 ¹ / ₂ " from bottom of slab; 13'1" span restrained.	175 psf	6 hrs.			7	1, 14	6
F/C-7-RC-39	7 ¹ / ₄ "	5 ³ / ₄ " (4010 psi) concrete core; 1" T&G board flooring; ¹ / ₂ " plaster undercoat; 4" × 3" × 10 lbs. R.S.J.; 2'6" C.R.S.; 1" down from top surface of concrete; 12' simply supported span; 2" × 1'3" clinker concrete insert.	95 psf	2 hrs.			7	1, 3	2
F/C-7-RC-40	7 ¹ / ₄ "	5 ³ / ₄ " (3220 psi) concrete core; 1" T&G flooring; ¹ / ₂ " plaster undercoat; 4" × 3" × 10 lbs. R.S.J.; 2'6" C.R.S.; 1" down from top surface of concrete; 12' simply supported span; 2" × 1'3" clinker concrete insert.	95 psf	4 hrs.			7	1, 7	4

(Continued)

TABLE 3.1—FLOOR/CEILING ASSEMBLIES—REINFORCED CONCRETE—(Continued)

ITEM CODE	ASSEMBLY THICKNESS	CONSTRUCTION DETAILS	PERFORMANCE		REFERENCE NUMBER			NOTES	REC. HOURS
			LOAD	TIME	PRE-BMS-92	BMS-92	POST-BMS-92		
F/C-7-RC-41	10" (2 1/4" Slab)	Ribbed floor, see Note 15 for details; slab 2 1/2" deep (3020 psi); 1/4" reinforcement bars at 6" pitch with 3/4" cover; beams 7 1/2" deep x 5" wide; 24" C.R.S.; 5/8" reinforcement bars two rows 1/2" vertically apart with 1" cover; 13'1" span restricted.	195 psf	1 hr. 4 min.			7	1, 2, 15	1
F/C-5-RC-42	5 1/2"	Composite ribbed concrete slab assembly; see Note 17 for details.	See Note 16	2 hrs.			43	16, 17	2
F/C-3-RC-43	3"	2500 psi concrete; 5/8" cover; fully restrained at test.	See Note 16	30 min.			43	16	1/2
F/C-3-RC-44	3"	2000 psi concrete; 5/8" cover; free or partial restraint at test.	See Note 16	45 min.			43	16	3/4
F/C-4-RC-45	4"	2500 psi concrete; 5/8" cover; fully restrained at test.	See Note 16	40 min.			43	16	2/3
F/C-4-RC-46	4"	2000 psi concrete; 3/4" cover; free or partial restraint at test.	See Note 16	1 hr. 15 min.			43	16	1 1/4
F/C-5-RC-47	5"	2500 psi concrete; 3/4" cover; fully restrained at test.	See Note 16	1 hr.			43	16	1
F/C-5-RC-48	5"	2000 psi concrete; 3/4" cover; free or partial restraint at test.	See Note 16	1 hr. 30 min.			43	16	1 1/2
F/C-6-RC-49	6"	2500 psi concrete; 1" cover; fully restrained at test.	See Note 16	1 hr. 30 min.			43	16	1 1/2
F/C-6-RC-50	6"	2000 psi concrete; 1" cover; free or partial restraint at test.	See Note 16	2 hrs.			43	16	2

Notes:

1. British test.
2. Failure mode - local back face temperature rise.
3. Tested for Grade "C" (2 hour) fire resistance.
4. Collapse imminent following hose stream.
5. Failure mode - flame thru.
6. Void formed with explosive force and report.
7. Achieved Grade "B" (4 hour) fire resistance (British).
8. Failure mode - collapse.
9. Test was run to 2 hours, but specimen was partially supported by the furnace at 1 1/4 hours.
10. Failure mode - average back face temperature.
11. Recommended endurance for nonload bearing performance only.
12. Floor maintained load bearing ability to 2 hours at which point test was terminated.
13. Test was run to 3 hours at which time failure mode 2 (above) was reached in spite of crack formation at 29 minutes.
14. Tested for Grade "A" (6 hour) fire resistance.
- 15.

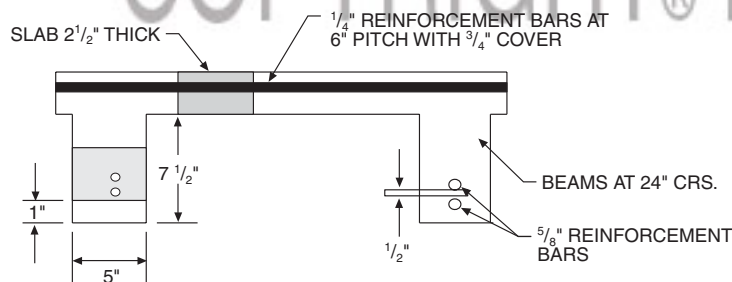

16. Load unspecified.
17. Total assembly thickness 5 1/2 inches. Three-inch thick blocks of molded excelsior bonded with portland cement used as inserts with 2 1/2-inch cover (concrete) above blocks and 3/4-inch gypsum plaster below. Nine-inch wide ribs containing reinforcing steel of unspecified size interrupted 20-inch wide segments of slab composite (i.e., plaster, excelsior blocks, concrete cover).

FIGURE 3.2—FLOOR/CEILING ASSEMBLIES—STEEL STRUCTURAL ELEMENTS

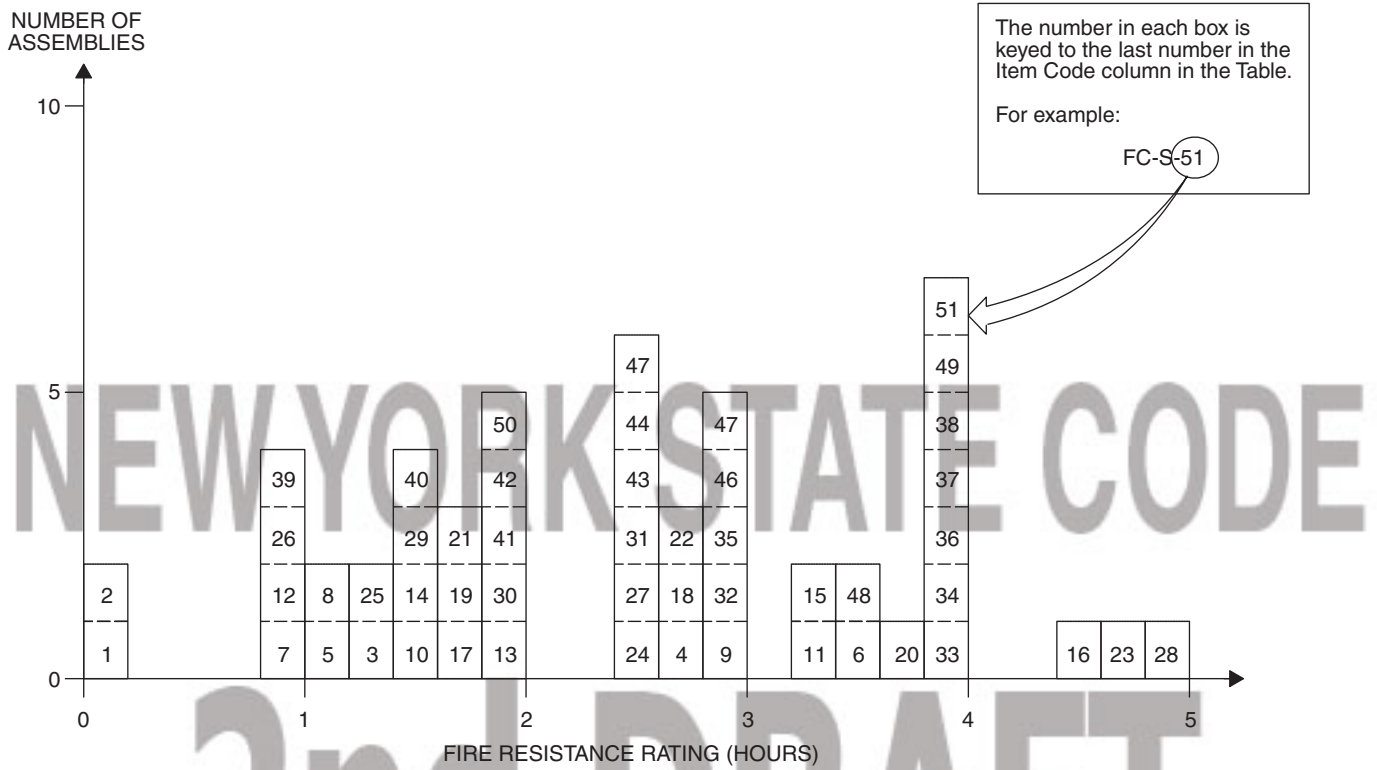

TABLE 3.2—FLOOR/CEILING ASSEMBLIES—STEEL STRUCTURAL ELEMENTS

ITEM CODE	MEMBRANE THICKNESS	CONSTRUCTION DETAILS	PERFORMANCE		REFERENCE NUMBER			NOTES	REC. HOURS
			LOAD	TIME	PRE-BMS-92	BMS-92	POST-BMS-92		
F/C-S-1	0"	- 10' × 13'6"; S.J. 103 - 24" o.c.; Deck: 2" concrete; Membrane: none.	145 psf	7 min.			3	1, 2, 3, 8	0
F/C-S-2	0"	- 10' × 13'6"; S.J. 103 - 24" o.c.; Deck: 2" concrete; Membrane: none	145 psf	7 min.			3	1, 2, 3, 8	0
F/C-S-3	1/2"	- 10' × 13'6"; S.J. 103 - 24" o.c.; Deck: 2" concrete 1:2:4; Membrane: furring 12" o.c.; Clips A, B, G; No extra reinforcement; 1/2" plaster - 1.5:2.5.	145 psf	1 hr. 15 min.			3	2, 3, 8	1 1/4
F/C-S-4	1/2"	- 10' × 13'6"; S.J. 103 - 24" o.c.; Deck: 2" concrete 1:2:4; Membrane: furring 16" o.c.; Clips D, E, F, G; Diagonal wire reinforcement; 1/2" plaster - 1.5:2.5.	145 psf	2 hrs. 46 min.			3	3, 8	2 3/4
F/C-S-5	1/2"	- 10' × 13'6"; S.J. 103 - 24" o.c.; Deck: 2" concrete 1:2:4; Membrane: furring 16" o.c.; Clips A, B, G; No extra reinforcement; 1/2" plaster - 1.5:2.5.	145 psf	1 hr. 4 min.			3	2, 3, 8	1

(Continued)

TABLE 3.2—FLOOR/CEILING ASSEMBLIES—STEEL STRUCTURAL ELEMENTS—(Continued)

ITEM CODE	MEMBRANE THICKNESS	CONSTRUCTION DETAILS	PERFORMANCE		REFERENCE NUMBER			NOTES	REC. HOURS
			LOAD	TIME	PRE-BMS-92	BMS-92	POST-BMS-92		
F/C-S-6	1/2"	10' × 13'6"; S.J. 103 - 24" o.c.; Deck: 2" concrete 1:2:4; Membrane: furring 16" o.c.; Clips D, E, F, G; Hexagonal mesh reinforcement; 1/2" plaster.	145 psf	3 hrs. 28 min.			3	2, 3, 8	2 1/3
F/C-S-7	1/2"	10' × 13'6"; S.J. 103 - 24" o.c.; Deck: 4 lbs. rib lath; 6" × 6" - 10 × 10 ga. reinforcement; 2" deck gravel concrete; Membrane: furring 16" o.c.; Clips C, E; Reinforcement: none; 1/2" plaster - 1.5:2.5 mill mix.	N/A	55 min.			3	5, 8	3/4
F/C-S-8	1/2"	Spec. 9' × 4'4"; S.J. 103 bar joists - 18" o.c.; Deck: 4 lbs. rib lath base; 6" × 6" - 10 × 10 ga. reinforcement; 2" deck 1:2:4 gravel concrete; Membrane: furring, 3/4" C.R.S., 16" o.c.; Clips C, E; Reinforcement: none; 1/2" plaster - 1.5:2.5 mill mix.	300 psf	1 hr. 10 min.			3	2, 3, 8	1
F/C-S-9	5/8"	10' × 13'6"; S.J. 103 - 24" o.c.; Deck: 2" concrete 1:2:4; Membrane: furring 12" o.c.; Clips A, B, G; Extra "A" clips reinforcement; 5/8" plaster - 1.5:2; 1.5:3.	145 psf	3 hrs.			3	6, 8	3
F/C-S-10	5/8"	18' × 13'6"; Joists, S.J. 103 - 24" o.c.; Deck: 4 lbs. rib lath; 6" × 6" - 10 × 10 ga. reinforcement; 2" deck 1:2:3.5 gravel concrete; Membrane: furring, spacing 16" o.c.; Clips C, E; Reinforcement: none; 5/8" plaster - 1.5:2.5 mill mix.	145 psf	1 hr. 25 min.			3	2, 3, 8	1 1/3
F/C-S-11	5/8"	10' × 13'6"; S.J. 103 - 24" o.c.; Deck: 2" concrete 1:2:4; Membrane: furring 12" o.c.; Clips D, E, F, G; Diagonal wire reinforcement; 5/8" plaster - 1.5:2; 0.5:3.	145 psf	3 hrs. 15 min.			3	2, 4, 8	3 1/4
F/C-S-12	5/8"	10' × 13'6"; Joists, S.J. 103 - 24" o.c.; Deck: 3.4 lbs. rib lath; 6" × 6" - 10 × 10 ga. reinforcement; 2" deck 1:2:4 gravel concrete; Membrane: furring 16" o.c.; Clips D, E, F, G; Reinforcement: none; 5/8" plaster - 1.5:2.5.	145 psf	1 hr.			3	7, 8	1
F/C-S-13	3/4"	Spec. 9' × 4'4"; S.J. 103 - 18" o.c.; Deck: 4 lbs. rib lath; 6" × 6" - 10 × 10 ga. reinforcement; 2" deck 1:2:4 gravel concrete; Membrane: furring, 3/4" C.R.S., 16" o.c.; Clips C, E; Reinforcement: none; 3/4" plaster - 1.5:2.5 mill mix.	300 psf	1 hr. 56 min.			3	3, 8	1 3/4

(Continued)

TABLE 3.2—FLOOR/CEILING ASSEMBLIES—STEEL STRUCTURAL ELEMENTS—(Continued)

ITEM CODE	MEMBRANE THICKNESS	CONSTRUCTION DETAILS	PERFORMANCE		REFERENCE NUMBER			NOTES	REC. HOURS
			LOAD	TIME	PRE-BMS-92	BMS-92	POST-BMS-92		
F/C-S-14	7/8"	Floor finish: 1" concrete; plate cont. weld; 4" - 7.7 lbs. "I" beams; Ceiling: 1/4" rods 12" o.c.; 7/8" gypsum sand plaster.	105 psf	1 hr. 35 min.			6	2, 4, 9, 10	1 1/2
F/C-S-15	1"	Floor finish: 1 1/2" L.W. concrete; 1/2" limestone cement; plate cont. weld; 5" - 10 lbs. "I" beams; Ceiling: 1/4" rods 12" o.c. tack welded to beams metal lath; 1" P. C. plaster.	165 psf	3 hrs. 20 min.			6	4, 9, 11	
F/C-S-16	1"	10' x 13'6"; S.J. 103 - 24" o.c.; Deck: 2" concrete 1:2:4; Membrane: furring 12" o.c.; Clips D, E, F, G; Hexagonal mesh reinforcement; 1" thick plaster - 1.5:2; 1.5:3.	145 psf	4 hrs. 26 min.			3	2, 4, 8	4 1/3
F/C-S-17	1"	10' x 13'6"; Joists - S.J. 103 - 24" o.c.; Deck: 3.4 lbs. rib lath; 6" x 6" - 10 x 10 ga. reinforcement; 2" deck 1:2:4 gravel concrete; Membrane: furring 16" o.c.; Clips D, E, F, G; 1" plaster.	145 psf	1 hr. 42 min.			3	2, 4, 8	1 2/3
F/C-S-18	1 1/8"	10' x 13'6"; S. J. 103 - 24" o.c.; Deck: 2" concrete 1:2:4; Membrane: furring 12" o.c.; Clips C, E, F, G; Diagonal wire reinforcement; 1 1/8" plaster.	145 psf	2 hrs. 44 min.			3	2, 4, 8	2 2/3
F/C-S-19	1 1/8"	10' x 13'6"; Joists - S.J. 103 - 24" o.c.; Deck: 1 1/2" gypsum concrete over; 1/2" gypsum board; Membrane: furring 12" o.c.; Clips D, E, F, G; 1 1/8" plaster - 1.5:2; 1.5:3.	145 psf	1 hr. 40 min.			3	2, 3, 8	1 2/3
F/C-S-20	1 1/8"	2 1/2" cinder concrete; 1/2" topping; plate 6" welds 12" o.c.; 5" - 18.9 lbs. "H" center; 5" - 10 lbs. "I" ends; 1" channels 18" o.c.; 1 1/8" gypsum sand plaster.	150 psf	3 hrs 43 min.			6	2, 4, 9, 11	3 2/3
F/C-S-21	1 1/4"	10' x 13'6"; Joists - S.J. 103 - 24" o.c.; Deck: 1 1/2" gypsum concrete over; 1/2" gypsum board base; Membrane: furring 12" o.c.; Clips D, E, F, G; 1 1/4" plaster - 1.5:2; 1.5:3.	145 psf	1 hr. 48 min.			3	2, 3, 8	1 2/3
F/C-S-22	1 1/4"	Floor finish: 1 1/2" limestone concrete; 1/2" sand cement topping; plate to beams 3 1/2"; 12" o.c. welded; 5" - 10 lbs. "I" beams; 1" channels 18" o.c.; 1 1/4" wood fiber gypsum sand plaster on metal lath.	292 psf	2 hrs. 45 min.			6	2, 4, 9, 10	2 3/4
F/C-S-23	1 1/2"	2 1/2" L.W. (gas exp.) concrete; Deck: 1/2" topping; plate 6 1/4" welds 12" o.c.; Beams: 5" - 18.9 lbs. "H" center; 5" - 10 lbs. "I" ends; Membrane: 1" channels 18" o.c.; 1 1/2" gypsum sand plaster.	150 psf	4 hrs. 42 min.			6	2, 4, 9	4 2/3

(Continued)

TABLE 3.2—FLOOR/CEILING ASSEMBLIES—STEEL STRUCTURAL ELEMENTS—(Continued)

ITEM CODE	MEMBRANE THICKNESS	CONSTRUCTION DETAILS	PERFORMANCE		REFERENCE NUMBER			NOTES	REC. HOURS
			LOAD	TIME	PRE-BMS-92	BMS-92	POST-BMS-92		
F/C-S-24	1½"	Floor finish: 1½" limestone concrete; ½" cement topping; plate 3½" - 12" o.c. welded; 5" - 10 lbs. "I" beams; Ceiling: 1" channels 18" o.c.; 1½" gypsum plaster.	292 psf	2 hrs. 34 min.			6	2, 4, 9, 10	2½
F/C-S-25	1½"	Floor finish: 1½" gravel concrete on exp. metal; plate cont. weld; 4" - 7.7 lbs. "I" beams; Ceiling: ¼" rods 12" o.c. welded to beams; 1½" fiber gypsum sand plaster.	70 psf	1 hr. 24 min.			6	2, 4, 9, 10	1⅓
F/C-S-26	2½"	Floor finish: bare plate; 6¼" welding - 12" o.c.; 5" - 18.9 lbs. "H" girders (inner); 5" - 10 lbs "I" girders (two outer); 1" channels 18" o.c.; 2" reinforced gypsum tile; ½" gypsum sand plaster.	122 psf	1 hr.			6	7, 9, 11	1
F/C-S-27	2½"	Floor finish: 2" gravel concrete; plate to beams 3½" - 12" o.c. welded; 4" - 7.7 lbs. "I" beams; 2" gypsum ceiling tiles; ½" 1:3 gypsum sand plaster.	105 psf	2 hrs. 31 min.			6	2, 4, 9, 10	2½
F/C-S-28	2½"	Floor finish: 1½" gravel concrete; ½" gypsum asphalt; plate continuous weld; 4" - 7.7 lbs. "I" beams; 12" - 31.8 lbs. "I" beams - girder at 5' from one end; 1" channels 18" o.c.; 2" reinforcement gypsum tile; ½" 1:3 gypsum sand plaster.	200 psf	4 hrs. 55 min.			6	2, 4, 9, 11	4⅔
F/C-S-29	¾"	Floor: 2" reinforced concrete or 2" precast reinforced gypsum tile; Ceiling: ¾" portland cement-sand plaster 1:2 for scratch coat and 1:3 for brown coat with 15 lbs. hydrated lime and 3 lbs. of short asbestos fiber bag per cement or ¾" sanded gypsum plaster 1:2 for scratch coat and 1:3 for brown coat.	See Note 12	1 hr. 30 min.		1		12, 13, 14	1½
F/C-S-30	¾"	Floor: 2¼" reinforced concrete or 2" reinforced gypsum tile; the latter with ¼" mortar finish; Ceiling: ¾" sanded gypsum plaster; 1:2 for scratch coat and 1:3 for brown coat.	See Note 12	2 hrs.		1		12, 13, 14	2
F/C-S-31	¾"	Floor: 2½" reinforced concrete or 2" reinforced gypsum tile; the latter with ¼" mortar finish; Ceiling: 1" neat gypsum plaster or ¾" gypsum-vermiculite plaster, ratio of gypsum to fine vermiculite 2:1 to 3:1.	See Note 12	2 hrs. 30 min.		1		12, 13, 14	2½

(Continued)

TABLE 3.2—FLOOR/CEILING ASSEMBLIES—STEEL STRUCTURAL ELEMENTS—(Continued)

ITEM CODE	MEMBRANE THICKNESS	CONSTRUCTION DETAILS	PERFORMANCE		REFERENCE NUMBER			NOTES	REC. HOURS
			LOAD	TIME	PRE-BMS-92	BMS-92	POST-BMS-92		
F/C-S-32	3/4"	Floor: 2 1/2" reinforced concrete or 2" reinforced gypsum tile; the latter with 1/2" mortar finish; Ceiling: 1" neat gypsum plaster or 3/4" gypsum-vermiculite plaster, ratio of gypsum to fine vermiculite 2:1 to 3:1.	See Note 12	3 hrs.		1		12, 13, 14	3
F/C-S-33	1"	Floor: 2 1/2" reinforced concrete or 2" reinforced gypsum slabs; the latter with 1/2" mortar finish; Ceiling: 1" gypsum-vermiculite plaster applied on metal lath and ratio 2:1 to 3:1 gypsum to vermiculite by weight.	See Note 12	4 hrs.		1		12, 13, 14	4
F/C-S-34	2 1/2"	Floor: 2" reinforced concrete or 2" precast reinforced portland cement concrete or gypsum slabs; precast slabs to be finished with 1/4" mortar top coat; Ceiling: 2" precast reinforced gypsum tile, anchored into beams with metal ties or clips and covered with 1/2" 1:3 sanded gypsum plaster.	See Note 12	4 hrs.		1		12, 13, 14	4
F/C-S-35	1"	Floor: 1:3:6 portland cement, sand and gravel concrete applied directly to the top of steel units and 1 1/2" thick at top of cells, plus 1/2" 1:2 1/2" cement-sand finish, total thickness at top of cells, 2"; Ceiling: 1" neat gypsum plaster, back of lath 2" or more from underside of cellular steel.	See Note 15	3 hrs.		1		15, 16, 17, 18	3
F/C-S-36	1"	Floor: same as F/C-S-35; Ceiling: 1" gypsum-vermiculite plaster (ratio of gypsum to vermiculite 2:1 to 3:1), the back of lath 2" or more from under-side of cellular steel.	See Note 15	4 hrs.		1		15, 16, 17, 18	4
F/C-S-37	1"	Floor: same as F/C-S-35; Ceiling: 1" neat gypsum plaster; back of lath 9" or more from underside of cellular steel.	See Note 15	4 hrs.		1		15, 16, 17, 18	4
F/C-S-38	1"	Floor: same as F/C-S-35; Ceiling: 1" gypsum-vermiculite plaster (ratio of gypsum to vermiculite 2:1 to 3:1), the back of lath being 9" or more from underside of cellular steel.	See Note 15	5 hrs.		1		15, 16, 17, 18	5
F/C-S-39	3/4"	Floor: asbestos paper 14 lbs./100 ft. ² cemented to steel deck with waterproof linoleum cement, wood screeds and 7/8" wood floor; Ceiling: 3/4" sanded gypsum plaster 1:2 for scratch coat and 1:3 for brown coat.	See Note 19	1 hr.		1		19, 20, 21, 22	1

(Continued)

TABLE 3.2—FLOOR/CEILING ASSEMBLIES—STEEL STRUCTURAL ELEMENTS—(Continued)

ITEM CODE	MEMBRANE THICKNESS	CONSTRUCTION DETAILS	PERFORMANCE		REFERENCE NUMBER			NOTES	REC. HOURS
			LOAD	TIME	PRE-BMS-92	BMS-92	POST-BMS-92		
F/C-S-40	3/4"	Floor: 1 1/2", 1:2:4 portland cement concrete; Ceiling: 3/4" sanded gypsum plaster 1:2 for scratch coat and 1:3 for brown coat.	See Note 19	1 hr. 30 min.		1		19, 20, 21, 22	1 1/2
F/C-S-41	3/4"	Floor: 2", 1:2:4 portland cement concrete; Ceiling: 3/4" sanded gypsum plaster, 1:2 for scratch coat and 1:3 for brown coat.	See Note 19	2 hrs.		1		19, 20, 21, 22	2
F/C-S-42	1"	Floor: 2", 1:2:4 portland cement concrete; Ceiling: 1" portland cement-sand plaster with 10 lbs. of hydrated lime for @ bag of cement 1:2 for scratch coat and 1:2 1/2" for brown coat.	See Note 19	2 hrs.		1		19, 20, 21, 22	2
F/C-S-43	1 1/2"	Floor: 2", 1:2:4 portland cement concrete; Ceiling: 1 1/2", 1:2 sanded gypsum plaster on ribbed metal lath.	See Note 19	2 hrs. 30 min.		1		19, 20, 21, 22	2 1/2
F/C-S-44	1 1/8"	Floor: 2", 1:2:4 portland cement concrete; Ceiling: 1 1/8", 1:1 sanded gypsum plaster.	See Note 19	2 hrs. 30 min.		1		19, 20, 21, 22	2 1/2
F/C-S-45	1"	Floor: 2 1/2", 1:2:4 portland cement concrete; Ceiling: 1", 1:2 sanded gypsum plaster.	See Note 19	2 hrs. 30 min.		1		19, 20, 21, 22	2 1/2
F/C-S-46	3/4"	Floor: 2 1/2", 1:2:4 portland cement concrete; Ceiling: 1" neat gypsum plaster or 3/4" gypsum-vermiculite plaster, ratio of gypsum to vermiculite 2:1 to 3:1.	See Note 19	3 hrs.		1		19, 20, 21, 22	3
F/C-S-47	1 1/8"	Floor: 2 1/2", 1:2:4 portland cement, sand and cinder concrete plus 1/2", 1:2 1/2" cement-sand finish; total thickness 3"; Ceiling: 1 1/8", 1:1 sanded gypsum plaster.	See Note 19	3 hrs.		1		19, 20, 21, 22	3
F/C-S-48	1 1/8"	Floor: 2 1/2", gas expanded portland cement-sand concrete plus 1/2", 1:2.5 cement-sand finish; total thickness 3"; Ceiling: 1 1/8", 1:1 sanded gypsum plaster.	See Note 19	3 hrs. 30 min.		1		19, 20, 21, 22	3 1/2
F/C-S-49	1"	Floor: 2 1/2", 1:2:4 portland cement concrete; Ceiling: 1" gypsum-vermiculite plaster; ratio of gypsum to vermiculite 2:1 to 3:1.	See Note 19	4 hrs.		1		19, 20, 21, 22	4
F/C-S-50	2 1/2"	Floor: 2", 1:2:4 portland cement concrete; Ceiling: 2" interlocking gypsum tile supported on upper face of lower flanges of beams, 1/2" 1:3 sanded gypsum plaster.	See Note 19	2 hrs.		1		19, 20, 21, 22	2

(Continued)

TABLE 3.2—FLOOR/CEILING ASSEMBLIES—STEEL STRUCTURAL ELEMENTS—(Continued)

ITEM CODE	MEMBRANE THICKNESS	CONSTRUCTION DETAILS	PERFORMANCE		REFERENCE NUMBER			NOTES	REC. HOURS
			LOAD	TIME	PRE-BMS-92	BMS-92	POST-BMS-92		
F/C-S-51	2 1/2"	Floor: 2", 1:2:4 portland cement concrete; Ceiling: 2" precast metal reinforced gypsum tile, 1/2" 1:3 sanded gypsum plaster (tile clipped to channels which are clipped to lower flanges of beams).	See Note 19	4 hrs.		1		19, 20, 21, 22	4

Notes:

1. No protective membrane over structural steel.
2. Performance time indicates first endpoint reached only several tests were continued to points where other failures occurred.
3. Load failure.
4. Thermal failure.
5. This is an estimated time to load bearing failure. The same joist and deck specimen was used for a later test with different membrane protection.
6. Test stopped at 3 hours to reuse specimen; no endpoint reached.
7. Test stopped at 1 hour to reuse specimen; no endpoint reached.
8. All plaster used = gypsum.
9. Specimen size - 18 feet by 13 1/2 inches. Floor deck - base material - 1/4-inch by 18-foot steel plate welded to "I" beams.
10. "I" beams - 24 inches o.c.
11. "I" beams - 48 inches o.c.
12. Apply to open web joists, pressed steel joists or rolled steel beams, which are not stressed beyond 18,000 lbs./in.² in flexure for open-web pressed or light rolled joists, and 20,000 lbs./in.² for American standard or heavier rolled beams.
13. Ratio of weight of portland cement to fine and coarse aggregates combined for floor slabs shall not be less than 1:6 1/2.
14. Plaster for ceiling shall be applied on metal lath which shall be tied to supports to give the equivalent of single No. 18 gage steel wires 5 inches o.c.
15. Load: maximum fiber stress in steel not to exceed 16,000 psi.
16. Prefabricated units 2 feet wide with length equal to the span, composed of two pieces of No. 18 gage formed steel welded together to give four longitudinal cells.
17. Depth not less than 3 inches and distance between cells no less than 2 inches.
18. Ceiling: metal lath tied to furring channels secured to runner channels hung from cellular steel.
19. Load: rolled steel supporting beams and steel plate base shall not be stressed beyond 20,000 psi in flexure.
Formed steel (with wide upper flange) construction shall not be stressed beyond 16,000 psi.
20. Some type of expanded metal or woven wire shall be embedded to prevent cracking in concrete flooring.
21. Ceiling plaster shall be metal lath wired to rods or channels which are clipped or welded to steel construction. Lath shall be no smaller than 18 gage steel wire and not more than 7 inches o.c.
22. The securing rods or channels shall be at least as effective as single 3/16-inch rods with 1-inch of their length bent over the lower flanges of beams with the rods or channels tied to this clip with 14 gage iron wire.

COPYRIGHT® ICC 2005

FIGURE 3.3—FLOOR/CEILING ASSEMBLIES—WOOD JOIST

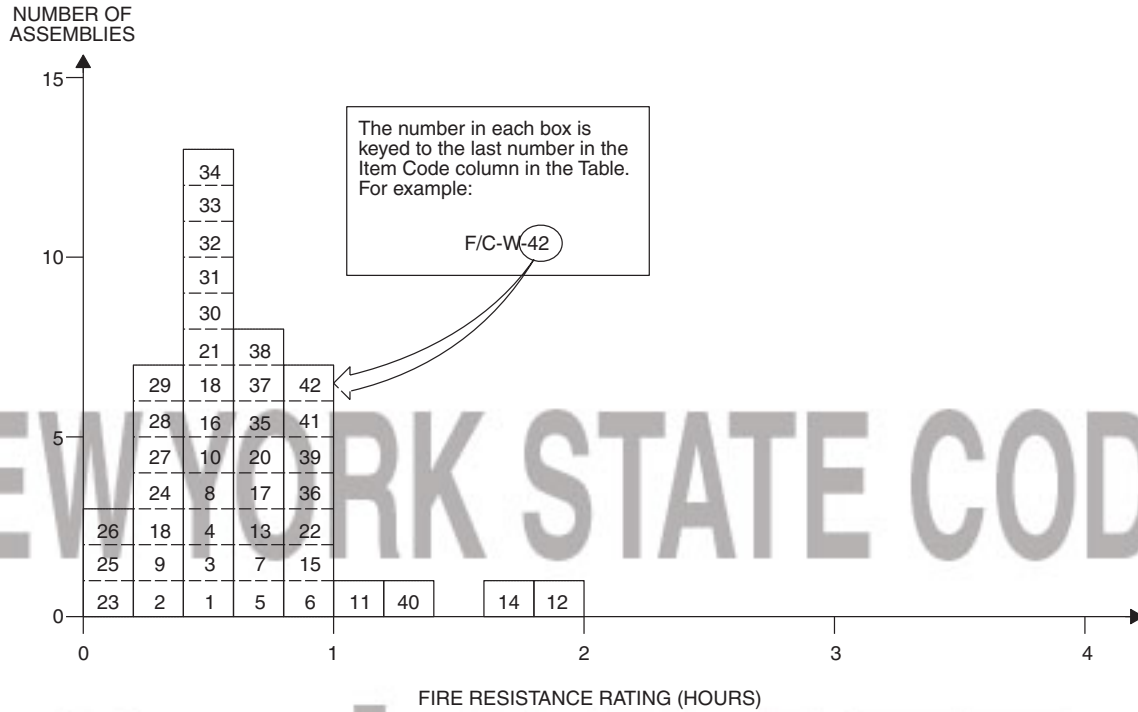

TABLE 3.3—FLOOR/CEILING ASSEMBLIES—WOOD JOIST

ITEM CODE	MEMBRANE THICKNESS	CONSTRUCTION DETAILS	PERFORMANCE		REFERENCE NUMBER			NOTES	REC. HOURS
			LOAD	TIME	PRE-BMS-92	BMS-92	POST-BMS-92		
F/C-W-1	3/8"	12' clear span - 2" x 9" wood joists; 18" o.c.; Deck: 1" T&G; Filler: 3" of ashes on 1/2" boards nailed to joist sides 2" from bottom; 2" air space; Membrane: 3/8" gypsum board.	60 psf	36 min.			7	1, 2	1/2
F/C-W-2	1/2"	12' clear span - 2" x 7" joists; 15" o.c.; Deck: 1" nominal lumber; Membrane: 1/2" fiber board.	60 psf	22 min.			7	1, 2, 3	1/4
F/C-W-3	1/2"	12' clear span - 2" x 7" wood joists; 16" o.c.; 2" x 1 1/2" bridging at center; Deck: 1" T&G; Membrane: 1/2" fiber board; 2 coats "distemper" paint.	30 psf	28 min.			7	1, 3, 15	1/3
F/C-W-4	3/16"	12' clear span - 2" x 7" wood joists; 16" o.c.; 2" x 1 1/2" bridging at center span; Deck: 1" nominal lumber; Membrane: 1/2" fiber board under 3/16" gypsum plaster.	30 psf	32 min.			7	1, 2	1/2
F/C-W-5	5/8"	As per previous F/C-W-4 except membrane is 5/8" lime plaster.	70 psf	48 min.			7	1, 2	3/4
F/C-W-6	5/8"	As per previous F/C-W-5 except membrane is 3/8" gypsum plaster on 22 gage 3/8" metal lath.	70 psf	49 min.			7	1, 2	3/4

(Continued)

TABLE 3.3—FLOOR/CEILING ASSEMBLIES—WOOD JOIST—(Continued)

ITEM CODE	MEMBRANE THICKNESS	CONSTRUCTION DETAILS	PERFORMANCE		REFERENCE NUMBER			NOTES	REC. HOURS
			LOAD	TIME	PRE-BMS-92	BMS-92	POST-BMS-92		
F/C-W-7	1/2"	As per previous F/C-W-6 except membrane is 1/2" fiber board under 1/2" gypsum plaster.	60 psf	43 min.			7	1, 2, 3	2/3
F/C-W-8	1/2"	As per previous F/C-W-7 except membrane is 1/2" gypsum board.	60 psf	33 min.			7	1, 2, 3	1/2
F/C-W-9	9/16"	12' clear span - 2" x 7" wood joists; 15" o.c.; 2" x 1 1/2" bridging at center; Deck: 1" nominal lumber; Membrane: 3/8" gypsum board; 3/16" gypsum plaster.	60 psf	24 min.			7	1, 2, 3	1/3
F/C-W-10	5/8"	As per F/C-W-9 except membrane is 5/8" gypsum plaster on wood lath.	60 psf	27 min.			7	1, 2, 3	1/3
F/C-W-11	7/8"	12' clear span - 2" x 9" wood joists; 15" o.c.; 2" x 1 1/2" bridging at center span; Deck: 1" T&G; Membrane: original ceiling joists have 3/8" plaster on wood lath; 4" metal hangers attached below joists creating 15" chases filled with mineral wool and closed with 7/8" plaster (gypsum) on 3/8" S.W.M. metal lath to form new ceiling surface.	75 psf	1 hr. 10 min.			7	1, 2	1
F/C-W-12	7/8"	12' clear span - 2" x 9" wood joists; 15" o.c.; 2" x 1 1/2" bridging at center; Deck: 1" T&G; Membrane: 3" mineral wool below joists; 3" hangers to channel below joists; 7/8" gypsum plaster on metal lath attached to channels.	75 psf	2 hrs.			7	1, 4	2
F/C-W-13	7/8"	12' clear span - 2" x 9" wood joists; 16" o.c.; 2" x 1 1/2" bridging at center span; Deck: 1" T&G on 1" bottoms on 3/4" glass wool strips on 3/4" gypsum board nailed to joists; Membrane: 3/4" glass wool strips on joists; 3/8" perforated gypsum lath; 1/2" gypsum plaster.	60 psf	41 min.			7	1, 3	2/3
F/C-W-14	7/8"	12' clear span - 2" x 9" wood joists; 15" o.c.; Deck: 1" T&G; Membrane: 3" foam concrete in cavity on 1/2" boards nailed to joists; wood lath nailed to 1" x 1 1/4" straps 14 o.c. across joists; 7/8" gypsum plaster.	60 psf	1 hr. 40 min.			7	1, 5	1 2/3
F/C-W-15	7/8"	12' clear span - 2" x 9" wood joists; 18" o.c.; Deck: 1" T&G; Membrane: 2" foam concrete on 1/2" boards nailed to joist sides 2" from joist bottom; 2" air space; 1" x 1 1/4" wood straps 14" o.c. across joists; 7/8" lime plaster on wood lath.	60 psf	53 min.			7	1, 2	3/4

(Continued)

TABLE 3.3—FLOOR/CEILING ASSEMBLIES—WOOD JOIST—(Continued)

ITEM CODE	MEMBRANE THICKNESS	CONSTRUCTION DETAILS	PERFORMANCE		REFERENCE NUMBER			NOTES	REC. HOURS
			LOAD	TIME	PRE-BMS-92	BMS-92	POST-BMS-92		
F/C-W-16	7/8"	12' clear span - 2" × 9" wood joists; Deck: 1" T&G; Membrane: 3" ashes on 1/2" boards nailed to joist sides 2" from joist bottom; 2" air space; 1" × 1 1/4" wood straps 14" o.c.; 7/8" gypsum plaster on wood lath.	60 psf	28 min.			7	1, 2	1/3
F/C-W-17	7/8"	As per previous F/C-W-16 but with lime plaster mix.	60 psf	41 min.			7	1, 2	2/3
F/C-W-18	7/8"	12' clear span - 2" × 9" wood joists; 18" o.c.; 2" × 1 1/2" bridging at center; Deck: 1" T&G; Membrane: 7/8" gypsum plaster on wood lath.	60 psf	36 min.			7	1, 2	1/2
F/C-W-19	7/8"	As per previous F/C-W-18 except with lime plaster membrane and deck is 1" nominal boards (plain edge).	60 psf	19 min.			7	1, 2	1/4
F/C-W-20	7/8"	As per F/C-W-19, except deck is 1" T&G boards.	60 psf	43 min.			7	1, 2	2/3
F/C-W-21	1	12' clear span - 2" × 9" wood joists; 16" o.c.; 2" × 1 1/2" bridging at center; Deck: 1" T&G; Membrane: 3/8" gypsum base board; 5/8" gypsum plaster.	70 psf	29 min.			7	1, 2	1/3
F/C-W-22	1 1/8"	12' clear span - 2" × 9" wood joists; 16" o.c.; 2" × 2" wood bridging at center; Deck: 1" T&G; Membrane: hangers, channel with 3/8" gypsum baseboard affixed under 3/4" gypsum plaster.	60 psf	1 hr.			7	1, 2, 3	1
F/C-W-23	3/8"	Deck: 1" nominal lumber; Joists: 2" × 7"; 15" o.c.; Membrane: 3/8" plasterboard with plaster skim coat.	60 psf	11 1/2 min.			12	2, 6	1/6
F/C-W-24	1/2"	Deck: 1" T&G lumber; Joists: 2" × 9"; 16" o.c.; Membrane: 1/2" plasterboard.	60 psf	18 min.			12	2, 7	1/4
F/C-W-25	1/2"	Deck: 1" T&G lumber; Joists: 2" × 7"; 16" o.c.; Membrane: 1/2" fiber insulation board.	30 psf	8 min.			12	2, 8	2/15
F/C-W-26	1/2"	Deck: 1" nominal lumber; Joists: 2" × 7"; 15" o.c.; Membrane: 1/2" fiber insulation board.	60 psf	8 min.			12	2, 9	2/15
F/C-W-27	5/8"	Deck: 1" nominal lumber; Joists: 2" × 7"; 15" o.c.; Membrane: 5/8" gypsum plaster on wood lath.	60 psf	17 min.			12	2, 10	1/4
F/C-W-28	5/8"	Deck: 1" T&G lumber; Joists: 2" × 9"; 16" o.c.; Membrane: 1/2" fiber insulation board; 1/2" plaster.	60 psf	20 min.			12	2, 11	1/3
F/C-W-29	No Membrane	Exposed wood joists.	See Note 13	15 min.		1		1, 12, 13, 14	1/4

(Continued)

TABLE 3.3—FLOOR/CEILING ASSEMBLIES—WOOD JOIST—(Continued)

ITEM CODE	MEMBRANE THICKNESS	CONSTRUCTION DETAILS	PERFORMANCE		REFERENCE NUMBER			NOTES	REC. HOURS
			LOAD	TIME	PRE-BMS-92	BMS-92	POST-BMS-92		
F/C-W-30	3/8"	Gypsum wallboard: 3/8" or 1/2" with 1 1/2" No. 15 gage nails with 3/16" heads spaced 6" centers with asbestos paper applied with paperhangers' paste and finished with casein paint.	See Note 13	25 min.		1		1, 12, 13, 14	1/2
F/C-W-31	1/2"	Gypsum wallboard: 1/2" with 1 3/4" No. 12 gage nails with 1/2" heads, 6" o.c., and finished with casein paint.	See Note 13	25 min.		1		1, 12, 13, 14	1/2
F/C-W-32	1/2"	Gypsum wallboard: 1/2" with 1 1/2" No. 12 gage nails with 1/2" heads, 18" o.c., with asbestos paper applied with paperhangers' paste and secured with 1 1/2" No. 15 gage nails with 3/16" heads and finished with casein paint; combined nail spacing 6" o.c.	See Note 13	30 min.		1		1, 12, 13, 14	1/2
F/C-W-33	3/8"	Gypsum wallboard: two layers 3/8" secured with 1 1/2" No. 15 gage nails with 3/8" heads, 6" o.c.	See Note 13	30 min.		1		1, 12, 13, 14	1/2
F/C-W-34	1/2"	Perforated gypsum lath: 3/8", plastered with 1 1/8" No. 13 gage nails with 5/16" heads, 4" o.c.; 1/2" sanded gypsum plaster.	See Note 13	30 min.		1		1, 12, 13, 14	1/2
F/C-W-35	1/2"	Same as F/C-W-34, except with 1 1/8" No. 13 gage nails with 3/8" heads, 4" o.c.	See Note 13	45 min.		1		1, 12, 13, 14	3/4
F/C-W-36	1/2"	Perforated gypsum lath: 3/8", nailed with 1 1/8" No. 13 gage nails with 3/8" heads, 4" o.c.; joints covered with 3" strips of metal lath with 1 3/4" No. 12 nails with 1/2" heads, 5" o.c.; 1/2" sanded gypsum plaster.	See Note 13	1 hr.		1		1, 12, 13, 14	1
F/C-W-37	1/2"	Gypsum lath: 3/8" and lower layer of 3/8" perforated gypsum lath nailed with 1 3/4" No. 13 nails with 5/16" heads, 4" o.c.; 1/2" sanded gypsum plaster or 1/2" portland cement plaster.	See Note 13	45 min.		1		1, 12, 13, 14	3/4
F/C-W-38	3/4"	Metal lath: nailed with 1 1/4" No. 11 nails with 3/8" heads or 6d common driven 1" and bent over, 6" o.c.; 3/4" sanded gypsum plaster.	See Note 13	45 min.		1		1, 12, 13, 14	3/4
F/C-W-39	3/4"	Same as F/C-W-38, except nailed with 1 1/2" No. 11 barbed roof nails with 7/16" heads, 6" o.c.	See Note 13	1 hr.		1		1, 12, 13, 14	1

(Continued)

TABLE 3.3—FLOOR/CEILING ASSEMBLIES—WOOD JOIST—(Continued)

ITEM CODE	MEMBRANE THICKNESS	CONSTRUCTION DETAILS	PERFORMANCE		REFERENCE NUMBER			NOTES	REC. HOURS
			LOAD	TIME	PRE-BMS-92	BMS-92	POST-BMS-92		
F/C-W-40	3/4"	Same as F/C-W-38, except with lath nailed to joists with additional supports for lath 27" o.c.; attached to alternate joists and consisting of two nails driven 1 1/4", 2" above bottom on opposite sides of the joists, one loop of No. 18 wire slipped over each nail; the ends twisted together below lath.	See Note 13	1 hr. 15 min.		1		1, 12, 13, 14	1 1/4
F/C-W-41	3/4"	Metal lath: nailed with 1 1/2" No. 11 barbed roof nails with 7/16" heads, 6 o.c., with 3/4" portland cement plaster for scratch coat and 1:3 for brown coat, 3 lbs. of asbestos fiber and 15 lbs. of hydrated lime/94 lbs. bag of cement.	See Note 13	1 hr.		1		1, 12, 13, 14	1
F/C-W-42	3/4"	Metal lath: nailed with 8d, No. 11 1/2 gage barbed box nails, 2 1/2" driven, 1 1/4" on slant and bent over, 6" o.c.; 3/4" sanded gypsum plaster, 1:2 for scratch coat and 1:3 for below coat.	See Note 13	1 hr.		1		1, 12, 13, 14	1

Notes:

1. Thickness indicates thickness of first membrane protection on ceiling surface.
2. Failure mode - flame thru.
3. Failure mode - collapse.
4. No endpoint reached at termination of test.
5. Failure imminent - test terminated.
6. Joist failure - 11.5 minutes; flame thru - 13.0 minutes; collapse - 24 minutes.
7. Joist failure - 17 minutes; flame thru - 18 minutes; collapse - 33 minutes.
8. Joist failure - 18 minutes; flame thru - 8 minutes; collapse - 30 minutes.
9. Joist failure - 12 minutes; flame thru - 8 minutes; collapse - 22 minutes.
10. Joist failure - 11 minutes; flame thru - 17 minutes; collapse - 27 minutes.
11. Joist failure - 17 minutes; flame thru - 20 minutes; collapse - 43 minutes.
12. Joists: 2-inch by 10-inch southern pine or Douglas fir; No. 1 common or better. Subfloor: 3/4-inch wood sheathing diaphragm of asbestos paper, and finish of tongue-and-groove wood flooring.
13. Loadings: not more than 1,000 psi maximum fiber stress in joists.
14. Perforations in gypsum lath are to be not less than 3/4-inch diameter with one perforation for not more than 16/in.² diameter.
15. "Distemper" is a British term for a water-based paint such as white wash or calcimine.

COPYRIGHT® ICC 2005

FIGURE 3.4—FLOOR/CEILING ASSEMBLIES—HOLLOW CLAY TILE WITH REINFORCED CONCRETE

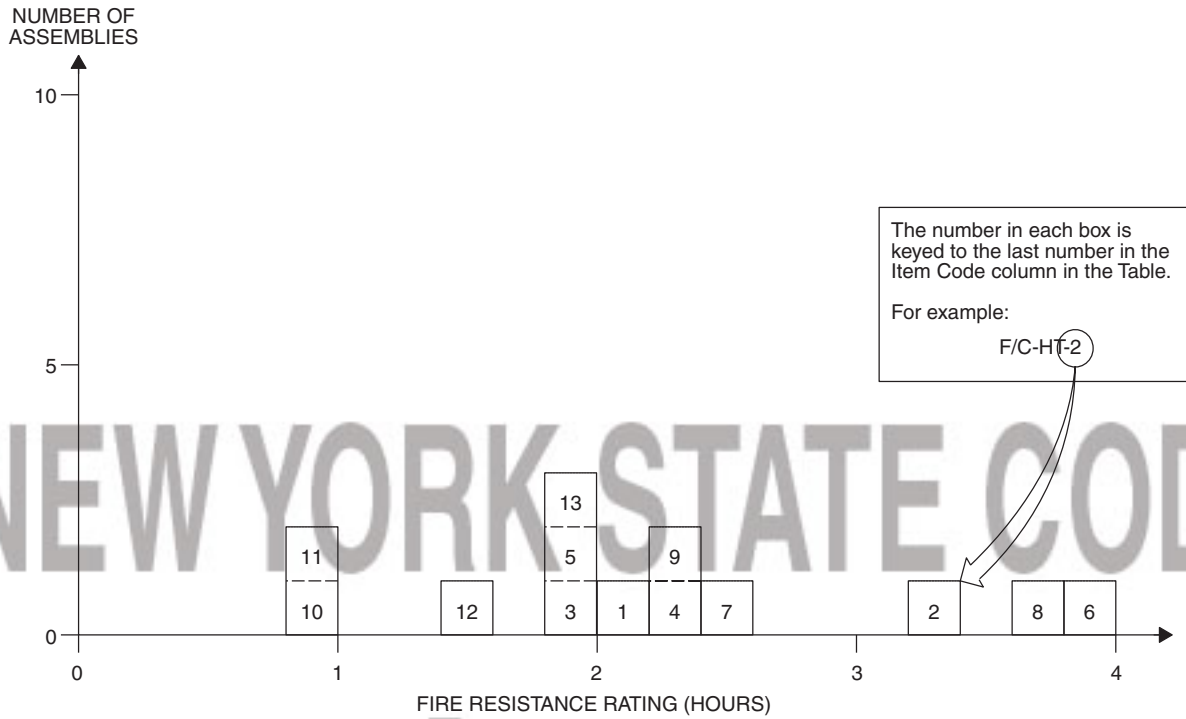

TABLE 3.4—FLOOR/CEILING ASSEMBLIES—HOLLOW CLAY TILE WITH REINFORCED CONCRETE

ITEM CODE	ASSEMBLY THICKNESS	CONSTRUCTION DETAILS	PERFORMANCE		REFERENCE NUMBER			NOTES	REC. HOURS
			LOAD	TIME	PRE-BMS-92	BMS-92	POST-BMS-92		
F/C-HT-1	6"	Cover: 1½" concrete (6080 psi); three cell hollow clay tiles, 12" × 12" × 4"; ¾" concrete between tiles including two ½" rebars with ¾" concrete cover; ½" plaster cover, lower.	75 psf	2 hrs. 7 min.			7	1, 2, 3	2
F/C-HT-2	6"	Cover: 1½" concrete (5840 psi); three cell hollow clay tiles, 12" × 12" × 4"; ¾" concrete between tiles including two ½" rebars each with ½" concrete cover and ⅝" filler tiles between hollow tiles; ½" plaster cover, lower.	61 psf	3 hrs. 23 min.			7	3, 4, 6	3⅓
F/C-HT-3	6"	Cover: 1½" concrete (6280 psi); three cell hollow clay tiles, 12" × 12" × 4"; ¾" concrete between tiles including two ½" rebars with ½" cover; ½" plaster cover, lower.	122 psf	2 hrs.			7	1, 3, 5, 8	2
F/C-HT-4	6"	Cover: 1½" concrete (6280 psi); three cell hollow clay tiles, 12" × 12" × 4"; ¾" concrete between tiles including two ½" rebars with ¾" cover; ½" plaster cover, lower.	115 psf	2 hrs. 23 min.			7	1, 3, 7	2⅓

(Continued)

TABLE 3.4—FLOOR/CEILING ASSEMBLIES—HOLLOW CLAY TILE WITH REINFORCED CONCRETE

ITEM CODE	ASSEMBLY THICKNESS	CONSTRUCTION DETAILS	PERFORMANCE		REFERENCE NUMBER			NOTES	REC. HOURS
			LOAD	TIME	PRE-BMS-92	BMS-92	POST-BMS-92		
F/C-HT-5	6"	Cover: 1 1/2" concrete (6470 psi); three cell hollow clay tiles, 12" x 12" x 4"; 3 1/4" concrete between tiles including two 1/2" rebars with 1/2" cover; 1/2" plaster cover, lower.	122 psf	2 hrs.			7	1, 3, 5, 8	2
F/C-HT-6	8"	Floor cover: 1 1/2" gravel cement (4300 psi); three cell, 12" x 12" x 6"; 3 1/2" space between tiles including two 1/2" rebars with 1" cover from concrete bottom; 1/2" plaster cover, lower.	165 psf	4 hrs.			7	1, 3, 9, 10	4
F/C-HT-7	9" (nom.)	Deck: 7/8" T&G on 2" x 1 1/2" bottoms (18" o.c.) 1 1/2" concrete cover (4600 psi); three cell hollow clay tiles, 12" x 12" x 4"; 3" concrete between tiles including one 3/4" rebar 3/4" from tile bottom; 3/4" plaster cover.	95 psf	2 hrs. 26 min.			7	4, 11, 12, 13	2 1/3
F/C-HT-8	9" (nom.)	Deck: 7/8" T&G on 2" x 1 1/2" bottoms (18" o.c.) 1 1/2" concrete cover (3850 psi); three cell hollow clay tiles, 12" x 12" x 4"; 3" concrete between tiles including one 3/4" rebar 3/4" from tile bottoms; 1/2" plaster cover.	95 psf	3 hrs. 28 min.			7	4, 11, 12, 13	
F/C-HT-9	9" (nom.)	Deck: 7/8" T&G on 2" x 1 1/2" bottoms (18" o.c.) 1 1/2" concrete cover (4200 psi); three cell hollow clay tiles, 12" x 12" x 4"; 3" concrete between tiles including one 3/4" rebar 3/4" from tile bottoms; 1/2" plaster cover.	95 psf	2 hrs. 14 min.			7	3, 5, 8, 11	
F/C-HT-10	5 1/2"	Fire clay tile (4" thick); 1 1/2" concrete cover; for general details, see Note 15.	See Note 14	1 hr.			43	15	1
F/C-HT-11	8"	Fire clay tile (6" thick); 2" cover.	See Note 14	1 hr.			43	15	1
F/C-HT-12	5 1/2"	Fire clay tile (4" thick); 1 1/2" cover; 5/8" gypsum plaster, lower.	See Note 14	1 hr. 30 min.			43	15	1 1/2
F/C-HT-13	8"	Fire clay tile (6" thick); 2" cover; 5/8" gypsum plaster, lower.	See Note 14	2 hrs.			43	15	1 1/2

Notes:

1. A generalized cross section of this floor type follows:

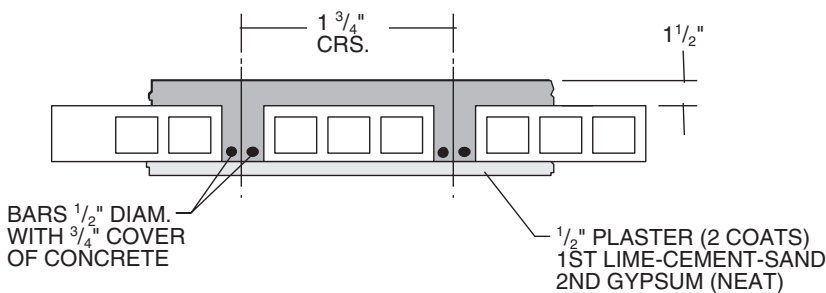

2. Failure mode - structural.
3. Plaster: base coat - lime-cement-sand; top coat - gypsum (neat).

(Continued)

TABLE 3.4—FLOOR/CEILING ASSEMBLIES—HOLLOW CLAY TILE WITH REINFORCED CONCRETE—(Continued)

4. Failure mode - collapse.
5. Test stopped before any endpoints were reached.
6. A generalized cross section of this floor type follows:

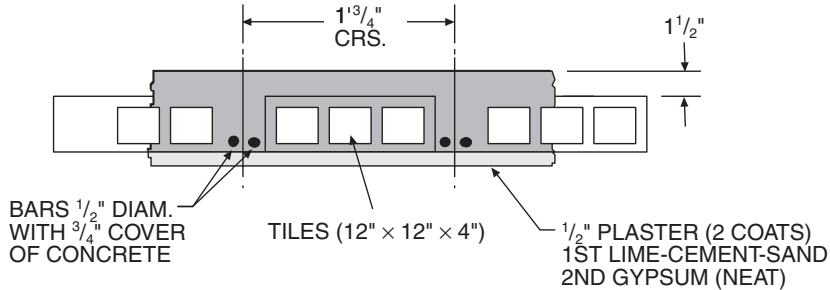

7. Failure mode - thermal - back face temperature rise.
8. Passed hose stream test.
9. Failed hose stream test.
10. Test stopped at 4 hours before any endpoints were reached.
11. A generalized cross section of this floor type follows:

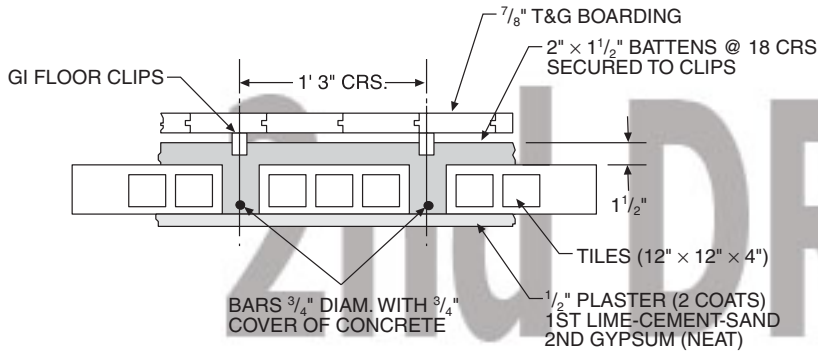

12. Plaster: base coat - retarded hemihydrate gypsum-sand; second coat - neat gypsum.
13. Concrete in Item 7 is P.C. based but with crushed brick aggregates while in Item 8 river sand and river gravels are used with the P.C.
14. Load - unspecified.
15. The 12-inch by 12-inch fire-clay tiles were laid end to end in rows spaced $2\frac{1}{2}$ inches or 4 inches apart. The reinforcing steel was placed between these rows and the concrete cast around them and over the tile to form the structural floor.

COPYRIGHT® ICC 2005