

SECTION IV—BEAMS

TABLE 4.1.1—REINFORCED CONCRETE BEAMS
DEPTH 10" TO LESS THAN 12"

ITEM CODE	DEPTH	CONSTRUCTION DETAILS	PERFORMANCE		REFERENCE NUMBER			NOTES	REC. HOURS
			LOAD	TIME	PRE-BMS-92	BMS-92	POST-BMS-92		
B-11-RC-1	11"	24" wide × 11" deep reinforced concrete "T" beam (3290 psi); Details: see Note 5 figure.	8.8 tons	4 hrs. 2 min.			7	1, 2, 14	4
B-10-RC-2	10"	24" wide × 10" deep reinforced concrete "T" beam (4370 psi); Details: see Note 6 figure.	8.8 tons	1 hr. 53 min.			7	1, 3	1 ³ / ₄
B-10-RC-3	10 ¹ / ₂ "	24" wide × 10 ¹ / ₂ " deep reinforced concrete "T" beam (4450 psi); Details: see Note 7 figure.	8.8 tons	2 hrs. 40 min.			7	1, 3	2 ² / ₃
B-11-RC-4	11"	24" wide × 11" deep reinforced concrete "T" beam (2400 psi); Details: see Note 8 figure.	8.8 tons	3 hrs. 32 min.			7	1, 3, 14	3 ¹ / ₂
B-11-RC-5	11"	24" wide × 11" deep reinforced concrete "T" beam (4250 psi); Details: see Note 9 figure.	8.8 tons	3 hrs. 3 min.			7	1, 3, 14	3
B-11-RC-6	11"	Concrete flange: 4" deep × 2' wide (4895 psi) concrete; Concrete beam: 7" deep × 6 ¹ / ₂ " wide beam; "I" beam reinforcement; 10" × 4 ¹ / ₂ " × 25 lbs. R.S.J.; 1" cover on flanges; Flange reinforcement: ³ / ₈ " diameter bars at 6" pitch parallel to "T"; ¹ / ₄ " diameter bars perpendicular to "T"; Beam reinforcement: 4" × 6" wire mesh No. 13 SWG; Span: 11' restrained; Details: see Note 10 figure.	10 tons	6 hrs.			7	1, 4	6
B-11-RC-7	11"	Concrete flange: 6" deep × 1'6 ¹ / ₂ " wide (3525 psi) concrete; Concrete beam: 5" deep × 8" wide precast concrete blocks 8 ³ / ₄ " long; "I" beam reinforcement; 7" × 4" × 16 lbs. R.S.J.; 2" cover on bottom; 1 ¹ / ₂ " cover on top; Flange reinforcement: two rows ¹ / ₂ " diameter rods parallel to "T"; Beam reinforcement: ¹ / ₈ " wire mesh perpendicular to 1"; Span: 1'3" simply supported; Details: see Note 11 figure.	3.9 tons	4 hrs.			7	1, 2	4
B-11-RC-8	11"	Concrete flange: 4" deep × 2' wide (3525 psi) concrete; Concrete beam 7" deep × 4 ¹ / ₂ " wide; (scaled from drawing); "I" beam reinforcement; 10" × 4 ¹ / ₂ " × 25 lbs. R.S.J.; no concrete cover on bottom; Flange reinforcement: ³ / ₈ " diameter bars at 6" pitch parallel to "T"; ¹ / ₄ " diameter bars perpendicular to "T"; Span: 11' restricted.	10 tons	4 hrs.			7	1, 2, 12	4

(Continued)

**TABLE 4.1.1—REINFORCED CONCRETE BEAMS
DEPTH 10" TO LESS THAN 12"—(Continued)**

11.

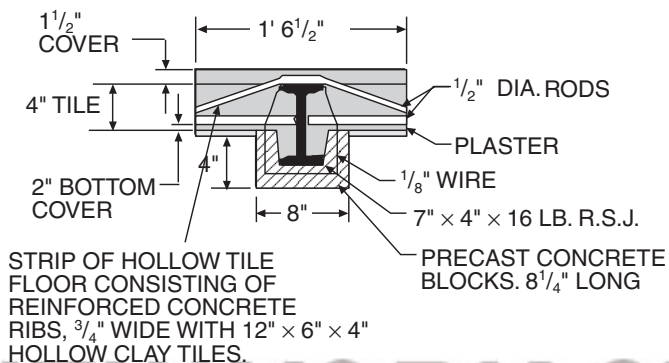

SPAN AND END CONDITIONS: -10'-3" (CLEAR).
SIMPLY SUPPORTED.

12.

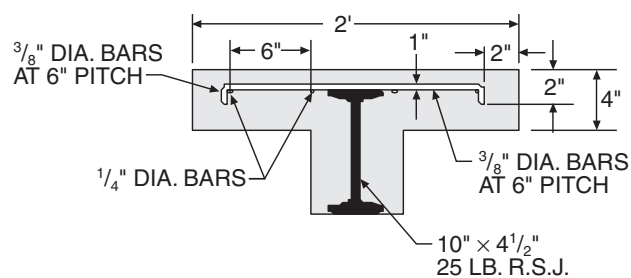

13.

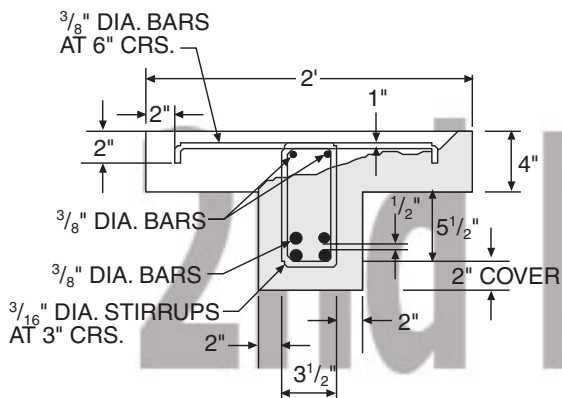

14. The different performances achieved by B-11-RC-1, B-11-RC-4 and B-11-RC-5 are attributable to differences in concrete aggregate compositions reported in the source document but unreported in this table. This demonstrates the significance of material composition in addition to other details.

COPYRIGHT® ICC 2005

**TABLE 4.1.2—REINFORCED CONCRETE BEAMS
DEPTH 12" TO LESS THAN 14"**

ITEM CODE	DEPTH	CONSTRUCTION DETAILS	PERFORMANCE		REFERENCE NUMBER			NOTES	REC. HOURS
			LOAD	TIME	PRE-BMS-92	BMS-92	POST-BMS-92		
B-12-RC-1	12"	12" × 8" section; 4160 psi aggregate concrete; Reinforcement: 4- ⁷ / ₈ " rebars at corners; 1" below each surface; ¹ / ₄ " stirrups 10" o.c.	5.5 tons	2 hrs.			7	1	2
B-12-RC-2	12"	Concrete flange: 4" deep × 2' wide (3045 psi) concrete at 35 days; Concrete beam: 8" deep; "I" beam reinforcement: 10" × 4 ¹ / ₂ " × 25 lbs. R.S.J.; 1" cover on flanges; Flange reinforcement: ³ / ₈ " diameter bars at 6" pitch parallel to "T"; ¹ / ₄ " diameter bars perpendicular to "T"; Beam reinforcement: 4" × 6" wire mesh No. 13 SWG; Span: 10' 3" simply supported.	10 tons	4 hrs.			7	2, 3, 5	4
B-13-RC-3	13"	Concrete flange: 4" deep × 2' wide (3825 psi) concrete at 46 days; Concrete beam: 9" deep × 8 ¹ / ₂ " wide; (scaled from drawing); "I" beam reinforcement: 10" × 4 ¹ / ₂ " × 25 lbs. R.S.J.; 3" cover on bottom flange; 1" cover on top flange; Flange reinforcement: ³ / ₈ " diameter bars at 6" pitch parallel to "T"; ¹ / ₄ " diameter bars perpendicular to "T"; Beam reinforcement: 4" × 6" wire mesh No. 13 SWG; Span: 11' restrained.	10 tons	6 hrs.			7	2, 3, 6, 8, 9	4
B-12-RC-4	12"	Concrete flange: 4" deep × 2' wide (3720 psi) concrete at 42 days; Concrete beam: 8" deep × 8 ¹ / ₂ " wide; (scaled from drawing); "I" beam reinforcement: 10" × 4 ¹ / ₂ " × 25 lbs. R.S.J.; 2" cover bottom flange; 1" cover top flange; Flange reinforcement: ³ / ₈ " diameter bars at 6" pitch parallel to "T"; ¹ / ₄ " diameter bars perpendicular to "T"; Beam reinforcement: 4" × 6" wire mesh No. 13 SWG; Span: 11' restrained.	10 tons	6 hrs.			7	1, 3, 4, 7, 8, 9	4

Notes:

1. Qualified for 2 hour use. (Grade "C," British) Test included hose stream and reload at 48 hours.
2. Load concentrated at mid span.
3. British test.
4. British test - qualified for 6 hour use (Grade "A").

(Continued)

**TABLE 4.1.2—REINFORCED CONCRETE BEAMS
DEPTH 12" TO LESS THAN 14"—(Continued)**

5.

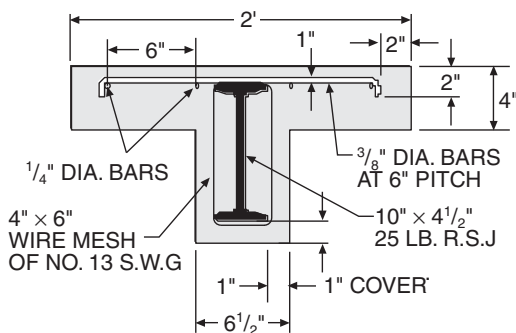

6.

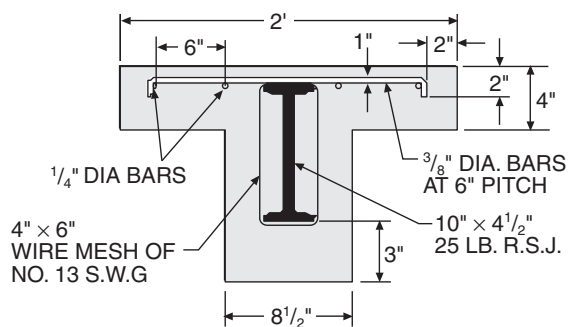

7.

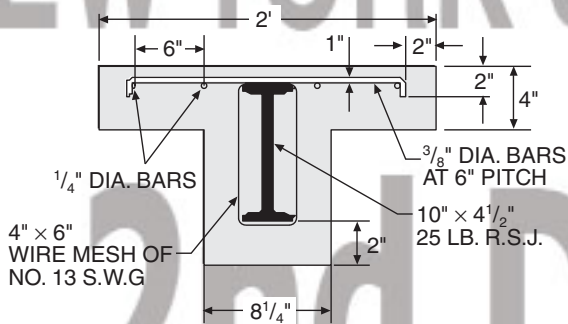

8. See Table 4.1.3, Note 5.

9. Hourly rating based upon B-12-RC-2 above.

NEW YORK STATE CODE

2nd DRAFT

COPYRIGHT® ICC 2005

**TABLE 4.1.3—REINFORCED CONCRETE BEAMS
DEPTH 14" TO LESS THAN 16"**

ITEM CODE	DEPTH	CONSTRUCTION DETAILS	PERFORMANCE		REFERENCE NUMBER			NOTES	REC. HOURS
			LOAD	TIME	PRE-BMS-92	BMS-92	POST-BMS-92		
B-15-RC-1	15"	Concrete flange: 4" deep × 2' wide (3290 psi) concrete; Concrete beam: 10" deep × 8½" wide; "T" beam reinforcement: 10" × 4½" × 25 lbs. R.S.J.; 4" cover on bottom flange; 1" cover on top flange; Flange reinforcement: ¾" diameter bars at 6" pitch parallel to "T"; ¼" diameter bars perpendicular to "T"; Beam reinforcement: 4" × 6" wire mesh No. 13 SWG; Span: 11' restrained.	10 tons	6 hrs.			7	1, 2, 3 5, 6	4
B-15-RC-2	15"	Concrete flange: 4" deep × 2' wide (4820 psi) concrete; Concrete beam: 10" deep × 8½" wide; "T" beam reinforcement: 10" × 4½" × 25 lbs. R.S.J.; 1" cover over wire mesh on bottom flange; 1" cover on top flange; Flange reinforcement: ¾" diameter bars at 6" pitch parallel to "T"; ¼" diameter bars perpendicular to "T"; Beam reinforcement: 4" × 6" wire mesh No. 13 SWG; Span: 11' restrained.	10 tons	6 hrs.			7	1, 2, 4, 5, 6	4

Notes:

1. Load concentrated at mid span.
2. Achieved 6 hour fire rating (Grade "A," British).
- 3.
- 4.

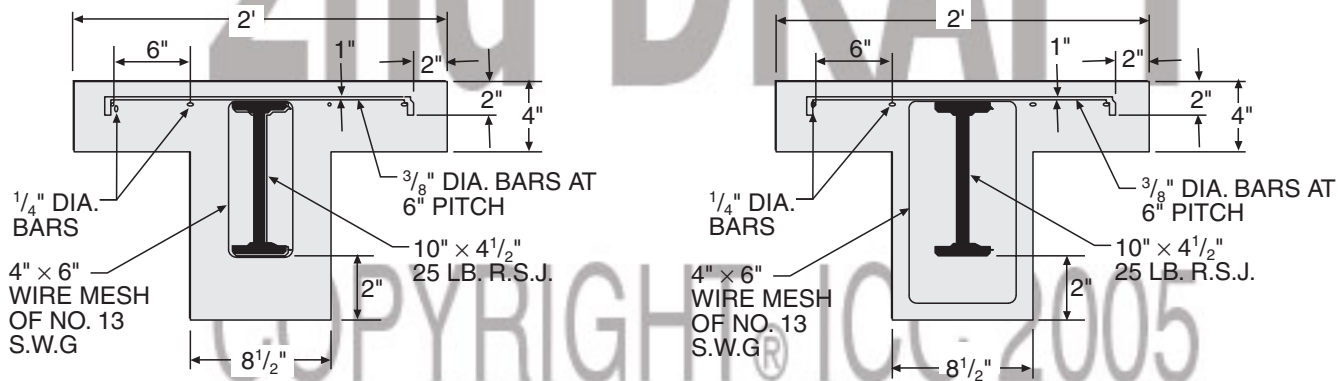

5. Section 43.147 of the 1979 edition of the *Uniform Building Code Standards* provides:

“A restrained condition in fire tests, as used in this standard, is one in which expansion at the supports of a load-carrying element resulting from the effects of the fire is resisted by forces external to the element. An unrestrained condition is one in which the load-carrying element is free to expand and rotate at its support.

“(R)estraint in buildings is defined as follows: Floor and roof assemblies and individual beams in buildings shall be considered restrained when the surrounding or supporting structure is capable of resisting the thermal expansion throughout the range of anticipated elevated temperatures. Construction not complying . . . is assumed to be free to rotate and expand and shall be considered as unrestrained.

“Restraint may be provided by the lateral stiffness of supports for floor and roof assemblies and intermediate beams forming part of the assembly. In order to develop restraint, connections must adequately transfer thermal thrusts to such supports. The rigidity of adjoining panels or structures shall be considered in assessing the capability of a structure to resist therm expansion.”

Because it is difficult to determine whether an existing building’s structural system is capable of providing the required restraint, the lower hourly ratings of a similar but unrestrained assembly have been recommended.
6. Hourly rating based upon Table 4.2.1, Item B-12-RC-2.

**TABLE 4.2.1—REINFORCED CONCRETE BEAMS—UNPROTECTED
DEPTH 10" TO LESS THAN 12"**

ITEM CODE	DEPTH	CONSTRUCTION DETAILS	PERFORMANCE		REFERENCE NUMBER			NOTES	REC. HOURS
			LOAD	TIME	PRE-BMS-92	BMS-92	POST-BMS-92		
B-SU-1	10"	10" × 4½" × 25 lbs. "I" beam.	10 tons	39 min.			7	1	1/3

Notes:

1. Concentrated at mid span.

**TABLE 4.2.2—STEEL BEAMS—CONCRETE PROTECTION
DEPTH 10" TO LESS THAN 12"**

ITEM CODE	DEPTH	CONSTRUCTION DETAILS	PERFORMANCE		REFERENCE NUMBER			NOTES	REC. HOURS
			LOAD	TIME	PRE-BMS-92	BMS-92	POST-BMS-92		
B-SC-1	10"	10" × 8" rectangle; aggregate concrete (4170 psi) with 1" top cover and 2" bottom cover; No. 13 SWG iron wire loosely wrapped at approximately 6" pitch about 7" × 4" × 16 lbs. "I" beam.	3.9 tons	3 hrs. 46 min.			7	1, 2, 3	3¾
B-SC-1	10"	10" × 8" rectangle; aggregate concrete (3630 psi) with 1" top cover and 2" bottom cover; No. 13 SWG iron wire loosely wrapped at approximately 6" pitch about 7" × 4" × 16 lbs. "I" beam.	5.5 tons	5 hrs. 26 min.			7	1, 4, 5, 6, 7	3¾

Notes:

1. Load concentrated at mid span.
2. Specimen 10-foot 3-inch clear span simply supported.
3. Passed Grade "C" fire resistance (British) including hose stream and reload.
4. Specimen 11-foot clear span - restrained.
5. Passed Grade "B" fire resistance (British) including hose stream and reload.
6. See Table 4.1.3, Note 5.
7. Hourly rating based upon B-SC-1 above.

COPYRIGHT® ICC 2005

SECTION V—DOORS

FIGURE 5.1—RESISTANCE OF DOORS TO FIRE EXPOSURE

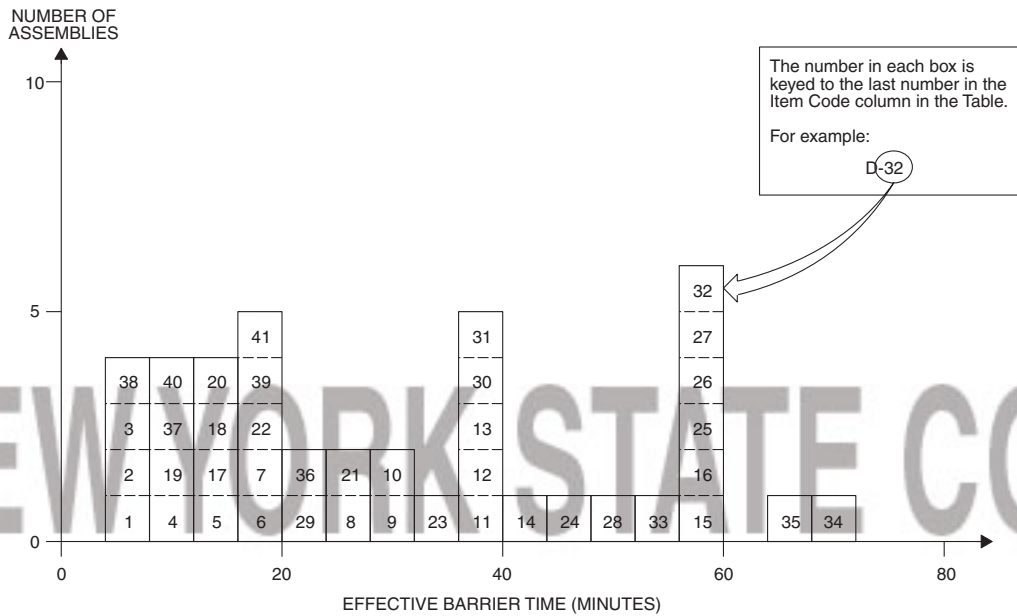

TABLE 5.1—RESISTANCE OF DOORS TO FIRE EXPOSURE

ITEM CODE	DOOR MINIMUM THICKNESS	CONSTRUCTION DETAILS	PERFORMANCE		REFERENCE NUMBER			NOTES	REC. (MIN.)
			EFFECTIVE BARRIER	EDGE FLAMING	PRE-BMS-92	BMS-92	POST-BMS-92		
D-1	3/8"	Panel door; pine perimeter (1 3/8"); painted (enamel).	5 min. 10 sec.	N/A			90	1, 2	5
D-2	3/8"	As above, with two coats U.L. listed intumescent coating.	5 min. 30 sec.	5 min.			90	1, 2, 7	5
D-3	3/8"	As D-1, with standard primer and flat interior paint.	5 min. 55 sec.	N/A			90	1, 3, 4	5
D-4	2 5/8"	As D-1, with panels covered each side with 1/2" plywood; edge grouted with sawdust filled plaster; door faced with 1/8" hardboard each side; paint see (5).	11 min. 15 sec.	3 min. 45 sec.			90	1, 2, 5, 7	10
D-5	3/8"	As D-1, except surface protected with glass fiber reinforced intumescent fire retardant coating.	16 min.	N/A			90	1, 3, 4, 7	15
D-6	1 5/8"	Door detail: As D-4, except with 1/8" cement asbestos board facings with aluminum foil; door edges protected by sheet metal.	17 min.	10 min. 15 sec.			90	1, 3, 4	15
D-7	1 5/8"	Door detail with 1/8" hardboard cover each side as facings; glass fiber reinforced intumescent coating applied.	20 min.	N/A			90	1, 3, 4, 7	20
D-8	1 5/8"	Door detail same as D-4; paint was glass reinforced epoxy intumescent.	26 min.	24 min. 45 sec.			90	1, 3, 4, 6, 7	25

(Continued)

TABLE 5.1—RESISTANCE OF DOORS TO FIRE EXPOSURE—(Continued)

ITEM CODE	DOOR MINIMUM THICKNESS	CONSTRUCTION DETAILS	PERFORMANCE		REFERENCE NUMBER			NOTES	REC. (MIN.)
			EFFECTIVE BARRIER	EDGE FLAMING	PRE-BMS-92	BMS-92	POST-BMS-92		
D-9	1 ⁵ / ₈ "	Door detail same as D-4 with facings of 1/8" cement asbestos board.	29 min.	3 min. 15 sec.			90	1, 2	5
D-10	1 ⁵ / ₈ "	As per D-9.	31 min. 30 sec.	7 min. 20 sec.			90	1, 3, 4	6
D-11	1 ⁵ / ₈ "	As per D-7; painted with epoxy intumescent coating including glass fiber roving.	36 min. 25 sec.	N/A			90	1, 3, 4	35
D-12	1 ⁵ / ₈ "	As per D-4 with intumescent fire retardant paint.	37 min. 30 sec.	24 min. 40 sec.			90	1, 3, 4	30
D-13	1 ¹ / ₂ " (nom.)	As per D-4, except with 24 ga. galvanized sheet metal facings.	39 min.	39 min.			90	1, 3, 4	39
D-14	1 ⁵ / ₈ "	As per D-9.	41 min. 30 sec.	17 min. 20 sec.			90	1, 3, 4, 6	20
D-15	—	Class C steel fire door.	60 min.	58 min.			90	7, 8	60
D-16	—	Class B steel fire door.	60 min.	57 min.			90	7, 8	60
D-17	1 ³ / ₄ "	Solid core flush door; core staves laminated to facings but not each other; Birch plywood facings 1/2" rebate in door frame for door; 3/32" clearance between door and wood frame.	15 min.	13 min.			37	11	13
D-18	1 ³ / ₄ "	As per D-17.	14 min.	13 min.			37	11	13
D-19	1 ³ / ₄ "	Door same as D-17, except with 16 ga. steel; 3/32" door frame clearance.	12 min.	—			37	9, 11	10
D-20	1 ³ / ₄ "	As per D-19.	16 min.	—			37	10, 11	10
D-21	1 ³ / ₄ "	Doors as per D-17; intumescent paint applied to top and side edges.	26 min.	—			37	11	25
D-22	1 ³ / ₄ "	Door as per D-17, except with 1/2" x 1/8" steel strip set into edges of door at top and side facing stops; matching strip on stop.	18 min.	6 min.			37	11	18
D-23	1 ³ / ₄ "	Solid oak door.	36 min.	22 min.			15	13	25
D-24	1 ⁷ / ₈ "	Solid oak door.	45 min.	35 min.			15	13	35
D-25	1 ⁷ / ₈ "	Solid teak door.	58 min.	34 min.			15	13	35
D-26	1 ⁷ / ₈ "	Solid (pitch) pine door.	57 min.	36 min.			15	13	35
D-27	1 ⁷ / ₈ "	Solid deal (pine) door.	57 min.	30 min.			15	13	30
D-28	1 ⁷ / ₈ "	Solid mahogany door.	49 min.	40 min.			15	13	45
D-29	1 ⁷ / ₈ "	Solid poplar door.	24 min.	3 min.			15	13, 14	5
D-30	1 ⁷ / ₈ "	Solid oak door.	40 min.	33 min.			15	13	35
D-31	1 ⁷ / ₈ "	Solid walnut door.	40 min.	15 min.			15	13	20
D-32	2 ⁵ / ₈ "	Solid Quebec pine.	60 min.	60 min.			15	13	60
D-33	2 ⁵ / ₈ "	Solid pine door.	55 min.	39 min.			15	13	40
D-34	2 ⁵ / ₈ "	Solid oak door.	69 min.	60 min.			15	13	60
D-35	2 ⁵ / ₈ "	Solid teak door.	65 min.	17 min.			15	13	60
D-36	1 ¹ / ₂ "	Solid softwood door.	23 min.	8.5 min.			15	13	10
D-37	3/4"	Panel door.	8 min.	7.5 min.			15	13	5
D-38	5/16"	Panel door.	5 min.	5 min.			15	13	5

(Continued)

TABLE 5.1—RESISTANCE OF DOORS TO FIRE EXPOSURE—(Continued)

ITEM CODE	DOOR MINIMUM THICKNESS	CONSTRUCTION DETAILS	PERFORMANCE		REFERENCE NUMBER			NOTES	REC. (MIN.)
			EFFECTIVE BARRIER	EDGE FLAMING	PRE-BMS-92	BMS-92	POST-BMS-92		
D-39	3/4"	Panel door, fire retardant treated.	17 1/2 min.	3 min.			15	13	8
D-40	3/4"	Panel door, fire retardant treated.	8 1/2 min.	8 1/2 min.			15	13	8
D-41	3/4"	Panel door, fire retardant treated.	16 3/4 min.	11 1/2 min.			15	13	8

Notes:

1. All door frames were of standard lumber construction.
2. Wood door stop protected by asbestos millboard.
3. Wood door stop protected by sheet metal.
4. Door frame protected with sheet metal and weather strip.
5. Surface painted with intumescent coating.
6. Door edge sheet metal protected.
7. Door edge intumescent paint protected.
8. Formal steel frame and door stop.
9. Door opened into furnace at 12 feet.
10. Similar door opened into furnace at 12 feet.
11. The doors reported in these tests represent the type contemporaries used as 20-minute solid-core wood doors. The test results demonstrate the necessity of having wall anchored metal frames, minimum clearances possible between door, frame and stops. They also indicate the utility of long throw latches and the possible use of intumescent paints to seal doors to frames in event of a fire.
12. Minimum working clearance and good latch closure are absolute necessities for effective containment for all such working door assemblies.
13. Based on British tests.
14. Failure at door - frame interface.

NEW YORK STATE CODE

2nd DRAFT

COPYRIGHT® ICC 2005