

APPENDIX E (IFGS)

STRUCTURAL SAFETY

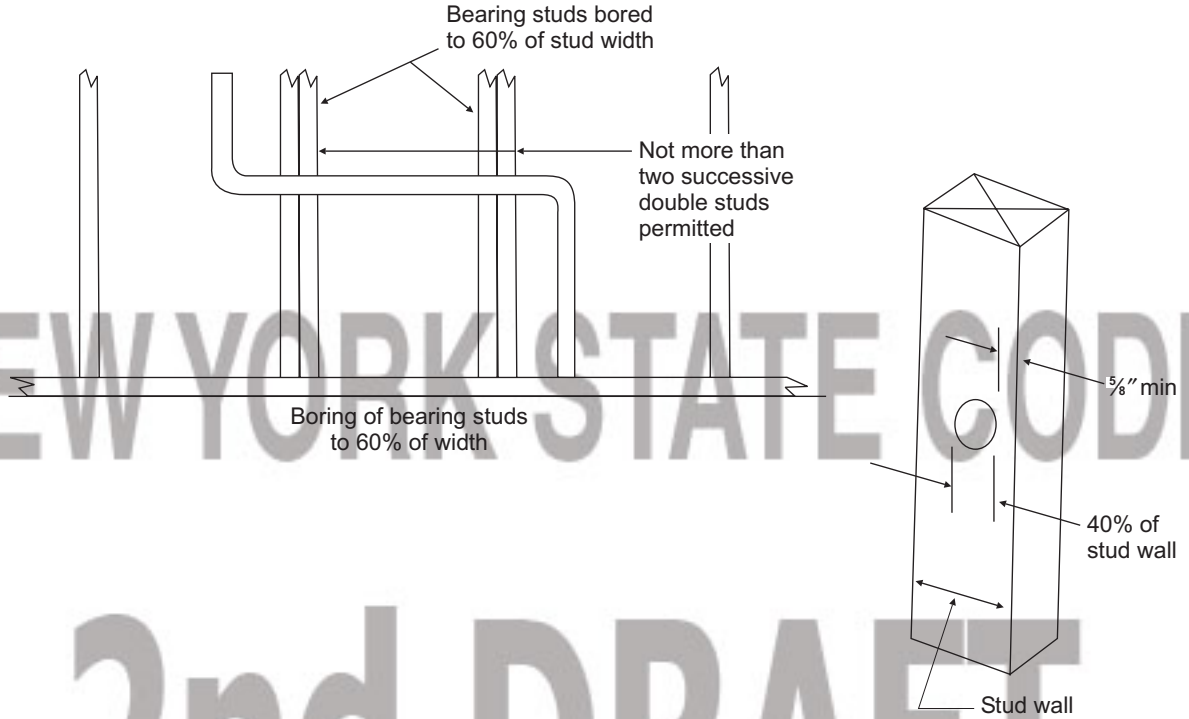

2nd DRAFT

COPYRIGHT © ICC 2005

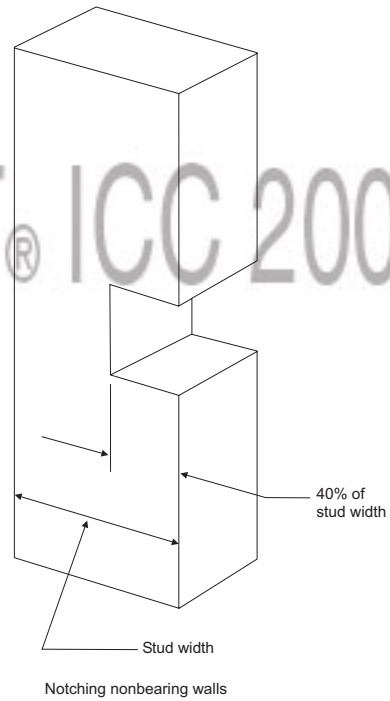
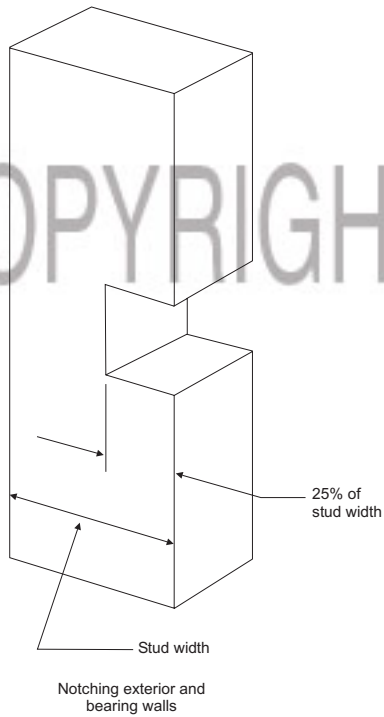

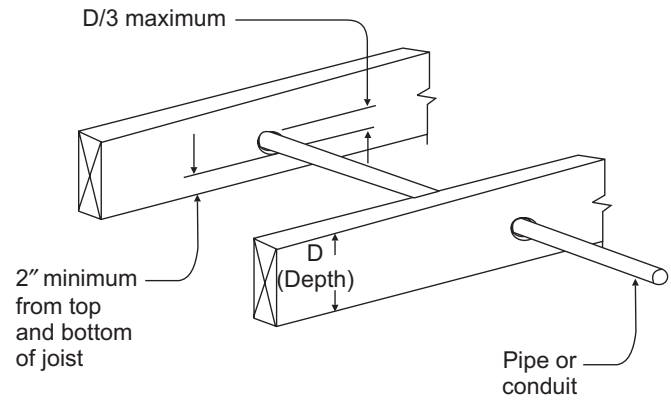

NEW YORK STATE CODE

BORED HOLES IN JOISTS

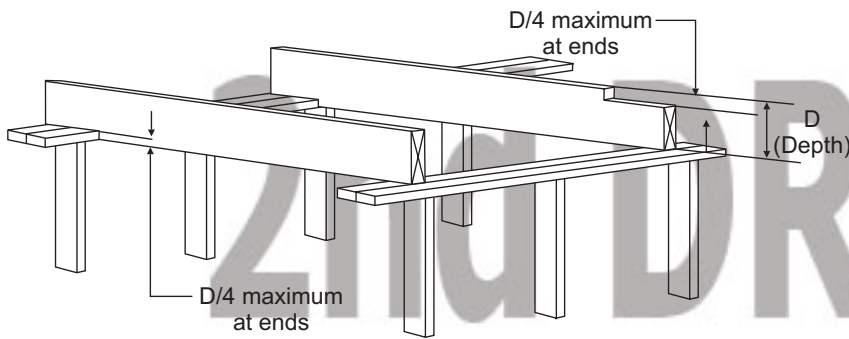

NOTCHES AT ENDS OF JOISTS

