

CHAPTER 31

VENTS

SECTION P3101 VENT SYSTEMS

P3101.1 General. This chapter shall govern the selection and installation of piping, tubing and fittings for vent systems. This chapter shall control the minimum diameter of vent pipes, circuit vents, branch vents and individual vents, and the size and length of vents and various aspects of vent stacks and stack vents. Additionally, this chapter regulates vent grades and connections, height above fixtures and relief vents for stacks and fixture traps, and the venting of sumps and sewers.

P3101.2 Trap seal protection. The plumbing system shall be provided with a system of vent piping that will permit the admission or emission of air so that the seal of any fixture trap shall not be subjected to a pneumatic pressure differential of more than 1 inch of water column (249 Pa).

P3101.2.1 Venting required. Every trap and trapped fixture shall be vented in accordance with one of the venting methods specified in this chapter.

P3101.3 Use limitations. The plumbing vent system shall not be utilized for purposes other than the venting of the plumbing system.

P3101.4 Flood resistance. In areas prone to flooding as established by Table R301.2(1), vents shall be located at or above the design flood elevation established in Section R323.1.

SECTION P3102 VENT STACKS AND STACK VENTS

P3102.1 Stack required. Every building shall have at least one vent stack or a stack vent which extends through roof. Such vent shall run undiminished in size and as directly as possible from the building drain through to the open air above the roof.

P3102.2 Vent connection to drainage system. Every vent stack shall connect to the base of the drainage stack. The vent stack shall connect at or below the lowest horizontal branch. Where the vent stack connects to the building drain, the connection shall be located within 10 pipe diameters downstream of the drainage stack. A stack vent shall be a vertical extension of the drainage stack.

P3102.3 Vent termination. Vent stacks or stack vents, other than required by Section P3102.1 may terminate to a stack-type air admittance valve.

SECTION P3103 VENT TERMINALS

P3103.1 Roof extension. At least one open vent pipe shall extend through a roof and shall be terminated at least 18 inches above the roof except that where a roof is to be used for any purpose other than weather protection, the vent extensions shall be run at least 7 feet (2134 mm) above the roof.

P3103.2 Frost closure. Every vent extension through a roof shall be a minimum of 3 inches (76 mm) in diameter. Any increase in the size of the vent shall be made inside the structure a minimum of 1 foot (305 mm) below the roof.

P3103.3 Flashings and sealing. The juncture of each vent pipe with the roof line shall be made water tight by an approved flashing. Vent extensions in walls and soffits shall be made weather tight by caulking.

P3103.4 Prohibited use. Vent terminals shall not be used as a flag pole or to support flag poles, TV aerials, or similar items, except when the piping has been anchored in an approved manner.

P3103.5 Location of vent terminal. An open vent terminal from a drainage system shall not be located less than 4 feet (1219 mm) directly beneath any door, openable window, or other air intake opening of the building or of an adjacent building, nor shall any such vent terminal be within 10 feet (3048 mm) horizontally of such an opening unless it is at least 2 feet (610 mm) above the top of such opening.

P3103.6 Extension through the wall. Vent terminals extending through the wall shall be prohibited including above grade penetrations, except for the fresh air inlet of the building trap, where provided.

SECTION P3104 VENT CONNECTIONS AND GRADES

3104.1 Connection. All individual branch and circuit vents shall connect to a vent stack, stack vent or extend to the open air.

Exception: Individual, branch and circuit vents shall be permitted to terminate at an air admittance valve in accordance with Section P3114.

P3104.2 Grade. All vent and branch vent pipes shall be so graded, connected and supported as to allow moisture and condensate to drain back to the soil or waste pipe by gravity.

P3104.3 Vent connection to drainage system. Every dry vent connecting to a horizontal drain shall connect above the centerline of the horizontal drain pipe.

P3104.4 Vertical rise of vent. Every dry vent shall rise vertically to a minimum of 6 inches (152 mm) above the flood level rim of the highest trap or trapped fixture being vented.

P3104.5 Height above fixtures. A connection between a vent pipe and a vent stack or stack vent shall be made at least 6 inches (152 mm) above the flood level rim of the highest fixture served by the vent. Horizontal vent pipes forming branch vents shall be at least 6 inches (152 mm) above the flood level rim of the highest fixture served.

P3104.6 Vent for future fixtures. Where the drainage piping has been roughed-in for future fixtures, a rough-in connection for a vent shall be installed a minimum of one-half the diameter

VENTS

of the drain. The vent rough-in shall connect to the vent system or shall be vented by other means as provided in this chapter. The connection shall be identified to indicate that the connection is a vent.

SECTION P3105 FIXTURE VENTS

P3105.1 Distance of trap from vent. Each fixture trap shall have a protecting vent located so that the slope and the developed length in the fixture drain from the trap weir to the vent fitting are within the requirements set forth in Table P3105.1.

Exception: The developed length of the fixture drain from the trap weir to the vent fitting for self-siphoning fixtures, such as water closets, shall not be limited.

TABLE P3105.1
MAXIMUM DISTANCE OF FIXTURE TRAP FROM VENT

SIZE OF TRAP (inches)	SLOPE (inch per foot)	DISTANCE FROM TRAP (feet)
1 $\frac{1}{4}$	$\frac{1}{4}$	5
1 $\frac{1}{2}$	$\frac{1}{4}$	6
2	$\frac{1}{4}$	8
3	$\frac{1}{8}$	12
4	$\frac{1}{8}$	16

For SI: 1 inch = 25.4 mm, 1 foot = 304.8 mm,
1 inch per foot = 83.3 mm/m.

P3105.2 Fixture drains. The total fall in a fixture drain due to pipe slope shall not exceed one pipe diameter, nor shall the vent pipe connection to a fixture drain, except for water closets, be below the weir of the trap, except as provided in Section P3105.3.

P3105.3 Vertical leg for waste fixture drains. A vertical leg (see Figure P3105.3) is permitted within a fixture drain of a waste fixture in accordance with the following criteria:

1. Minimum trap diameter shall be in accordance with Table P3201.7.
2. The diameter of Section A shall be equal to the diameter of the trap.
3. The length of Section A shall not be less than 8 inches (203 mm) and in accordance with Table P3105.1.
4. The diameter of Section B shall be one pipe size larger than the diameter of Section A.
5. The length of Section B shall not be more than 36 inches (914 mm).
6. The diameter of Section C shall be one pipe size larger than the diameter of Section B.
7. The total length of Section A and Section C shall not exceed the distance allowed in Table P3105.1.
8. Bends shall be the diameter of the largest connected section.

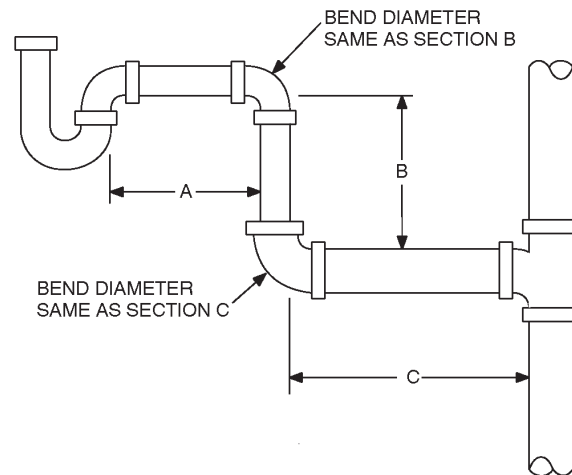

FIGURE P3105.3
VERTICAL LEG FIXTURE DRAIN SCHEMATIC

P3105.4 Crown vent. A vent shall not be installed within two pipe diameters of the trap weir.

SECTION P3106 INDIVIDUAL VENT

P3106.1 Individual vent permitted. Each trap and trapped fixture is permitted to be provided with an individual vent. The individual vent shall connect to the fixture drain of the trap or trapped fixture being vented.

SECTION P3107 COMMON VENT

P3107.1 Individual vent as common vent. An individual vent is permitted to vent two traps or trapped fixtures as a common vent. The traps or trapped fixtures being common vented shall be located on the same floor level.

P3107.2 Connection at the same level. Where the fixture drains being common vented connect at the same level, the vent connection shall be at the interconnection of the fixture drains or downstream of the interconnection.

P3107.3 Connection at different levels. Where the fixture drains connect at different levels, the vent shall connect as a vertical extension of the vertical drain. The vertical drain pipe connecting the two fixture drains shall be considered the vent for the lower fixture drain, and shall be sized in accordance with Table P3107.3. The upper fixture shall not be a water closet.

**TABLE P3107.3
COMMON VENT SIZES**

PIPE SIZE (inches)	MAXIMUM DISCHARGE FROM UPPER FIXTURE DRAIN (d.f.u.)
1½	1
2	4
2½ to 3	6

For SI: 1 inch = 25.4 mm.

SECTION P3108 WET VENTING

P3108.1 Wet vent permitted. Any combination of fixtures within two bathroom groups located on the same floor level are permitted to be vented by a wet vent. The wet vent shall be considered the vent for the fixtures and shall extend from the connection of the dry vent along the direction of the flow in the drain pipe to the most downstream fixture drain connection to the horizontal branch drain. Only the fixtures within the bathroom groups shall connect to the wet vented horizontal branch drain. Any additional fixtures shall discharge downstream of the wet vent. [See Figures P3108.1(1), P3108.1(2), P3108.1(3) and P3108.1(4) for typical wet vent configurations.]

P3108.2 Vent connections. The dry vent connection to the wet vent shall be an individual vent or common vent to the lavatory, bidet, shower or bathtub.

P3108.3 Size. Horizontal and vertical wet vents shall be of a minimum size as specified in Table P3108.3, based on the fixture unit discharge to the wet vent.

**TABLE P3108.3
WET VENT SIZE**

WET VENT PIPE SIZE (inches)	FIXTURE UNIT LOAD (d.f.u.)
1½	1
2	4
2½	6
3	12
4	32

For SI: 1 inch = 25.4 mm.

P3108.4 Vertical wet vent. A combination of fixtures located on the same floor level are permitted to be vented by a vertical wet vent. The vertical wet vent shall extend from the connection to the dry vent down to the lowest fixture drain connection. Each fixture shall connect independently to the vertical wet vent. All water closet drains shall connect at the same elevation. Other fixture drains shall connect above or at the same elevation as the water closet fixture drains. The dry vent connection to the vertical wet vent shall be an individual or common vent serving one or two fixtures. [See Figures P3108.1(4) and P3108.1(5) for typical vertical wet vent configurations.]

SECTION P3109 WASTE STACK VENT

P3109.1 Waste stack vent permitted. A waste stack shall be considered a vent for all of the fixtures discharging to the stack where installed in accordance with the requirements of this section.

P3109.2 Stack installation. The waste stack shall be vertical, and both horizontal and vertical offsets shall be prohibited. Every fixture drain shall connect separately to the waste stack. The stack shall not receive the discharge of water closets or urinals. (See Figure P3109.2 for typical waste stack venting.)

P3109.3 Stack vent. A stack vent shall be provided for the waste stack. The size of the stack vent shall be equal to the size of the waste stack.

P3109.4 Waste stack size. The waste stack shall be sized based on the total discharge to the stack and the discharge within a branch interval in accordance with Table P3109.4. The waste stack shall be the same size throughout the length of the waste stack.

**TABLE P3109.4
WASTE STACK VENT SIZE**

STACK SIZE (inches)	MAXIMUM NUMBER OF FIXTURE UNITS (d.f.u.)	
	Total discharge into one branch interval	Total discharge for stack
1½	1	2
2	2	4
2½	No limit	8
3	No limit	24
4	No limit	50

For SI: 1 inch = 25.4 mm.

SECTION P3110 CIRCUIT VENTING

P3110.1 Circuit vent permitted. A maximum of eight fixtures connected to a horizontal branch drain shall be permitted to be circuit vented. Each fixture drain shall connect horizontally to the horizontal branch being circuit vented. The horizontal branch drain shall be classified as a vent from the most downstream fixture drain connection to the most upstream fixture drain connection to the horizontal branch.

P3110.2 Vent connection. The circuit vent connection shall be located between the two most upstream fixture drains. The vent shall connect to the horizontal branch and shall be installed in accordance with Section P3104. The circuit vent pipe shall not receive the discharge of any soil or waste.

P3110.3 Slope and size of horizontal branch. The maximum slope of the vent section of the horizontal branch drain shall be one unit vertical in 12 units horizontal (8-percent slope). The entire length of the vent section of the horizontal branch drain shall be sized for the total drainage discharge to the branch in accordance with Table P3005.4.1.

VENTS

P3110.4 Additional fixtures. Fixtures, other than the circuit-vented fixtures, are permitted to discharge to the horizontal branch drain. Such fixtures shall be located on the same floor as the circuit-vented fixtures and shall be either individually or common vented. (See Figure P3110.4 for a typical circuit vent with additional noncircuit vented fixtures.)

**SECTION P3111
COMBINATION WASTE AND VENT SYSTEM**

P3111.1 Type of fixtures. A combination waste and vent system shall not serve fixtures other than floor drains, standpipes, sinks, lavatories and drinking fountains. A combination waste and vent system shall not receive the discharge of a food waste grinder.

P3111.2 Installation. The only vertical pipe of a combination drain and vent system shall be the connection between the fixture drain of a sink, lavatory, standpipe or drinking fountain, and the horizontal combination waste and vent pipe. The maximum vertical distance shall be 8 feet (2438 mm).

P3111.2.1 Slope. The horizontal combination waste and vent pipe shall have a maximum slope of one-half unit vertical in 12 units horizontal (4-percent slope). The minimum slope shall be in accordance with Section P3005.3.

P3111.2.2 Connection. The combination waste and vent pipe shall connect to a horizontal drain that is vented or a vent shall connect to the combination waste and vent. The vent connecting to the combination waste and vent pipe shall extend vertically a minimum of 6 inches (152 mm) above the flood level rim of the highest fixture being vented before offsetting horizontally.

P3111.2.3 Vent size. The vent shall be sized for the total fixture unit load in accordance with Section P3113.1.

P3111.2.4 Fixture branch or drain. The fixture branch or fixture drain shall connect to the combination waste and vent within a distance specified in Table P3105.1. The combination waste and vent pipe shall be considered the vent for the fixture.

P3111.3 Size. The minimum size of a combination waste and vent pipe shall be in accordance with Table P3111.3.

**TABLE P3111.3
SIZE OF COMBINATION WASTE AND VENT PIPE**

DIAMETER PIPE (inches)	MAXIMUM NUMBER OF FIXTURE UNITS (d.f.u.)	
	Connecting to a horizontal branch or stack	Connecting to a building drain or building subdrain
2	3	4
2½	6	26
3	12	31
4	20	50

For SI: 1 inch = 25.4 mm.

**SECTION P3112
ISLAND FIXTURE VENTING**

P3112.1 Limitation. Island fixture venting shall not be permitted for fixtures other than sinks and lavatories. Kitchen sinks with a dishwasher waste connection, a food waste grinder, or both, in combination with the kitchen sink waste, shall be permitted to be vented in accordance with this section.

P3112.2 Vent connection. The island fixture vent shall connect to the fixture drain as required for an individual or common vent. The vent shall rise vertically to above the drainage outlet of the fixture being vented before offsetting horizontally or vertically downward. The vent or branch vent for multiple island fixture vents shall extend to a minimum of 6 inches (152 mm) above the highest island fixture being vented before connecting to the outside vent terminal.

P3112.3 Vent installation below the fixture flood level rim. The vent located below the flood level rim of the fixture being vented shall be installed as required for drainage piping in accordance with Chapter 30, except for sizing. The vent shall be sized in accordance with Section P3113.1. The lowest point of the island fixture vent shall connect full size to the drainage system. The connection shall be to a vertical drain pipe or to the top half of a horizontal drain pipe. Cleanouts shall be provided in the island fixture vent to permit rodding of all vent piping located below the flood level rim of the fixtures. Rodding in both directions shall be permitted through a cleanout.

**SECTION P3113
VENT PIPE SIZING**

P3113.1 Size of vents. The minimum required diameter of individual vents, branch vents, circuit vents, vent stacks and stack vents shall be at least one-half the required diameter of the drain served. The required size of the drain shall be determined in accordance with Chapter 30. Vent pipes shall be not less than 1¼ inch (32 mm) in diameter. Vents exceeding 40 feet (12 192 mm) in developed length shall be increased by one nominal pipe size for the entire developed length of the vent pipe.

P3113.2 Developed length. The developed length of individual, branch, and circuit vents shall be measured from the farthest point of vent connection to the drainage system, to the point of connection to the vent stack, stack vent or termination outside of the building.

P3113.3 Branch vents. Where branch vents are connected to a common branch vent, the common branch vent shall be sized in accordance with this section, based on the size of the common horizontal drainage branch that is or would be required to serve the total drainage fixture unit (dfu) load being vented.

P3113.4 Sump vents. Sump vent sizes shall be determined in accordance with Sections P3113.4.1 and P3113.4.2.

P3113.4.1 Sewage pumps and sewage ejectors other than pneumatic. Drainage piping below sewer level shall be vented independently in a similar manner to that of a gravity system. Building sump vent sizes for sumps with sewage pumps or sewage ejectors, other than pneumatic, shall be determined in accordance with Table P3113.4.1.

**TABLE P3113.4.1
SIZE AND LENGTH OF SUMP VENTS**

DISCHARGE CAPACITY OF PUMP (gpm)	MAXIMUM DEVELOPED LENGTH OF VENT (feet) ^a				
	Diameter of vent (inches)				
	1 ¹ / ₄	1 ¹ / ₂	2	2 ¹ / ₂	3
10	No limit ^b	No limit	No limit	No limit	No limit
20	270	No limit	No limit	No limit	No limit
40	72	160	No limit	No limit	No limit
60	31	75	270	No limit	No limit

For SI: 1 inch = 25.4 mm, 1 foot = 304.8 mm, 1 gallon-per-minute (gpm) = 3.785 L/m.

- a. Developed length plus an appropriate allowance for entrance losses and friction due to fittings, changes in direction and diameter. Suggested allowances shall be obtained from NBS Monograph 31. An allowance of 50 percent of the developed length shall be assumed if a more precise value is not available.
- b. Actual values greater than 500 feet.

P3113.4.2 Pneumatic sewage ejectors. The air pressure relief pipe from a pneumatic sewage ejector shall be connected to an independent vent stack terminating as required for vent extensions through the roof. The relief pipe shall be sized to relieve air pressure inside the ejector to atmospheric pressure, but shall not be less than 1¹/₄ inches (32 mm) in size.

SECTION P3114 AIR ADMITTANCE VALVES

P3114.1 General. Vent systems utilizing air admittance valves shall comply with this section. Individual- and branch-type air admittance valves shall conform to ASSE 1051. Stack type air admittance valves shall conform to ASSE 1050.

P3114.2 Installation. The valves shall be installed in accordance with the requirements of this section and the manufacturer's installation instructions. Air admittance valves shall be installed after the DWV testing required by Section P2503.5.1 or P2503.5.2 has been performed.

P3114.3 Where permitted. Individual vents, branch vents, circuit vents and stack vents shall be permitted to terminate with a connection to an air admittance valve, except as prohibited by Section P3102.1.

P3114.4 Location. Individual and branch air admittance valves shall be located a minimum of 4 inches (102 mm) above the horizontal branch drain or fixture drain being vented. Stack-type air admittance valves shall be located a minimum of 6 inches (152 mm) above the flood level rim of the highest fixture being vented. The air admittance valve shall be located within the maximum developed length permitted for the vent. The air admittance valve shall be installed a minimum of 6 inches (152 mm) above insulation materials where installed in attics.

P3114.5 Access and ventilation. Access shall be provided to all air admittance valves. The valve shall be located within a ventilated space that allows air to enter the valve.

P3114.6 Size. The air admittance valve shall be rated for the size of the vent to which the valve is connected.

P3114.7 Vent required. Within each plumbing system, a minimum of one stack vent or a vent stack shall extend outdoors to the open air.

VENTS

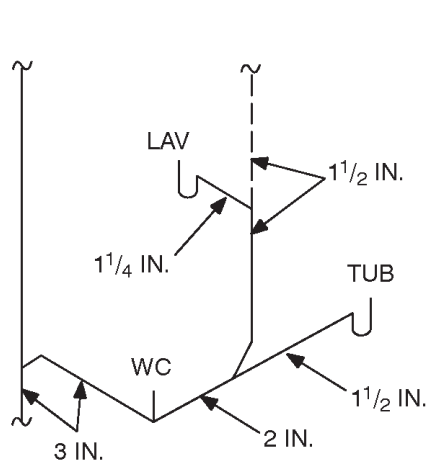

A. TYPICAL SINGLE-BATH ARRANGEMENT

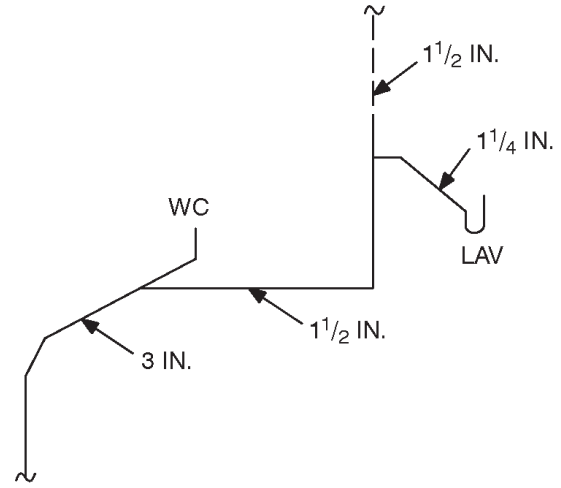

B. TYPICAL POWDER ROOM

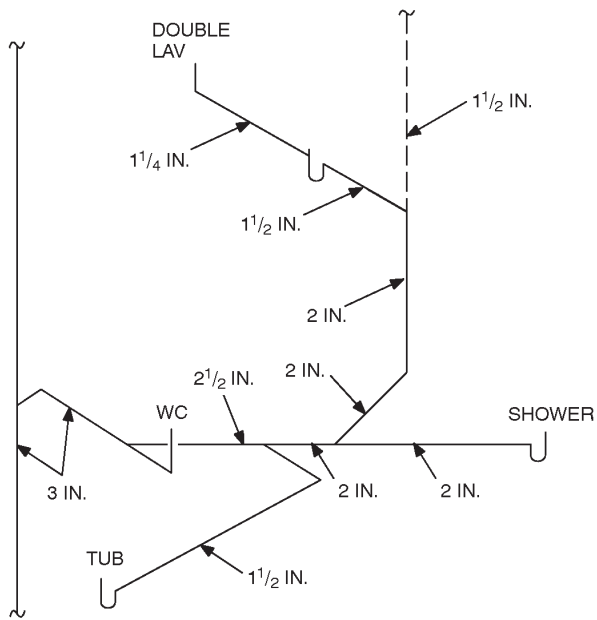

C. MORE ELABORATE SINGLE-BATH ARRANGEMENT

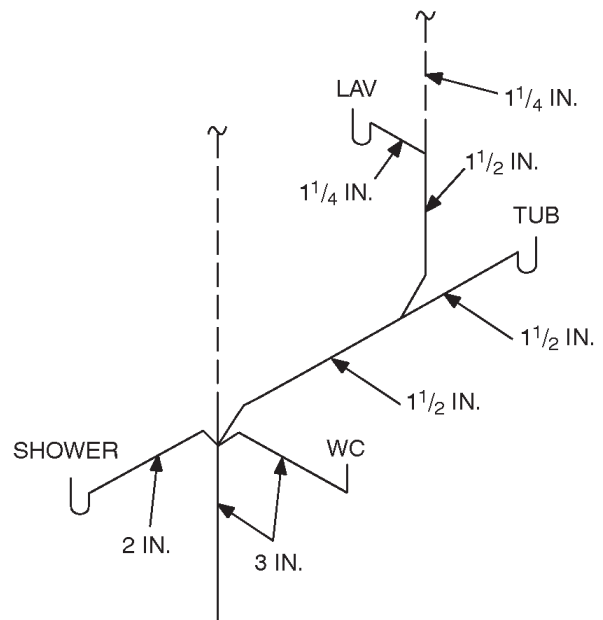

D. COMBINATION WET- AND STACK-VENTING WITH STACK FITTING

For SI: 1 inch = 25.4 mm.

NOTE: This figure is for illustration purposes only and the written text shall apply.

FIGURE P3108.1(1)
TYPICAL SINGLE-BATH WET-VENT ARRANGEMENTS

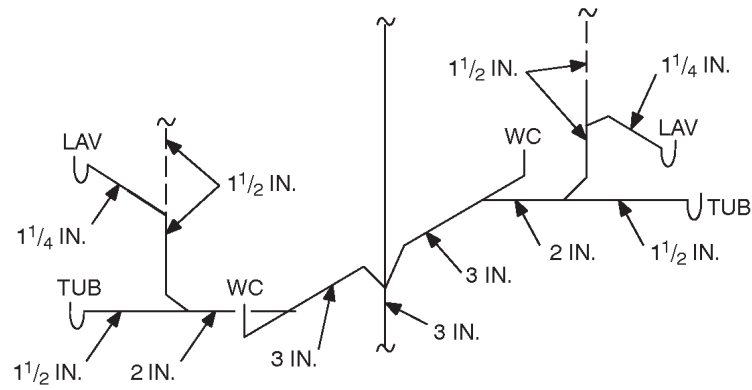

A. TYPICAL BACK-TO-BACK BATHS

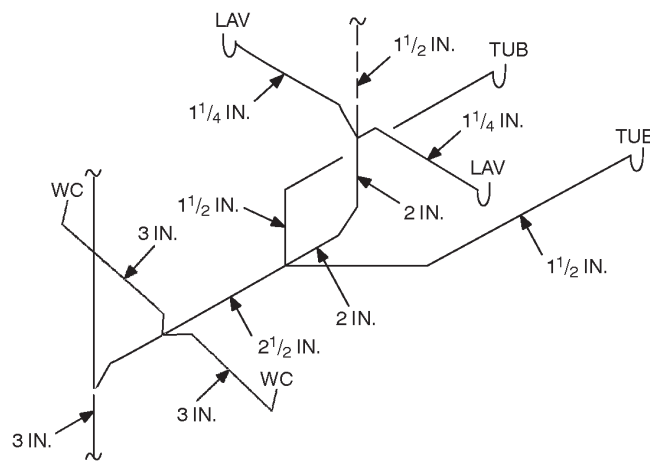

B. DOUBLE BATHS WITH FIXTURES ON COMMON HORIZONTAL BRANCH, COMMON WET VENT

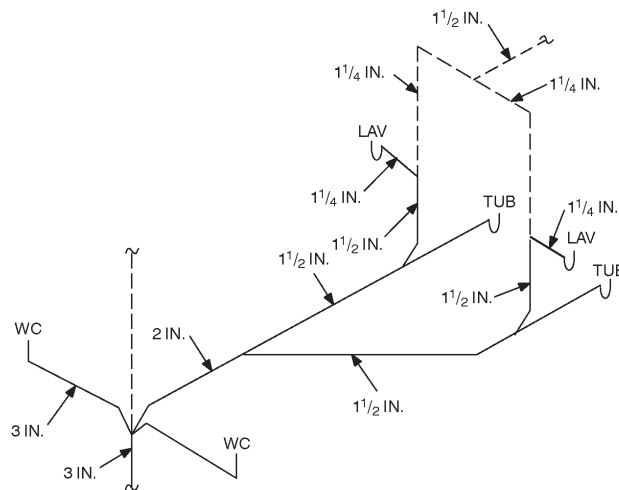

C. DOUBLE BATHS WITH WASTE FIXTURES ON COMMON HORIZONTAL BRANCH, INDIVIDUAL WET VENTS

For SI: 1 inch = 25.4 mm.

NOTE: This figure is for illustration purposes only and the written text shall apply.

FIGURE P3108.1(2)
TYPICAL DOUBLE-BATH WET-VENT ARRANGEMENTS

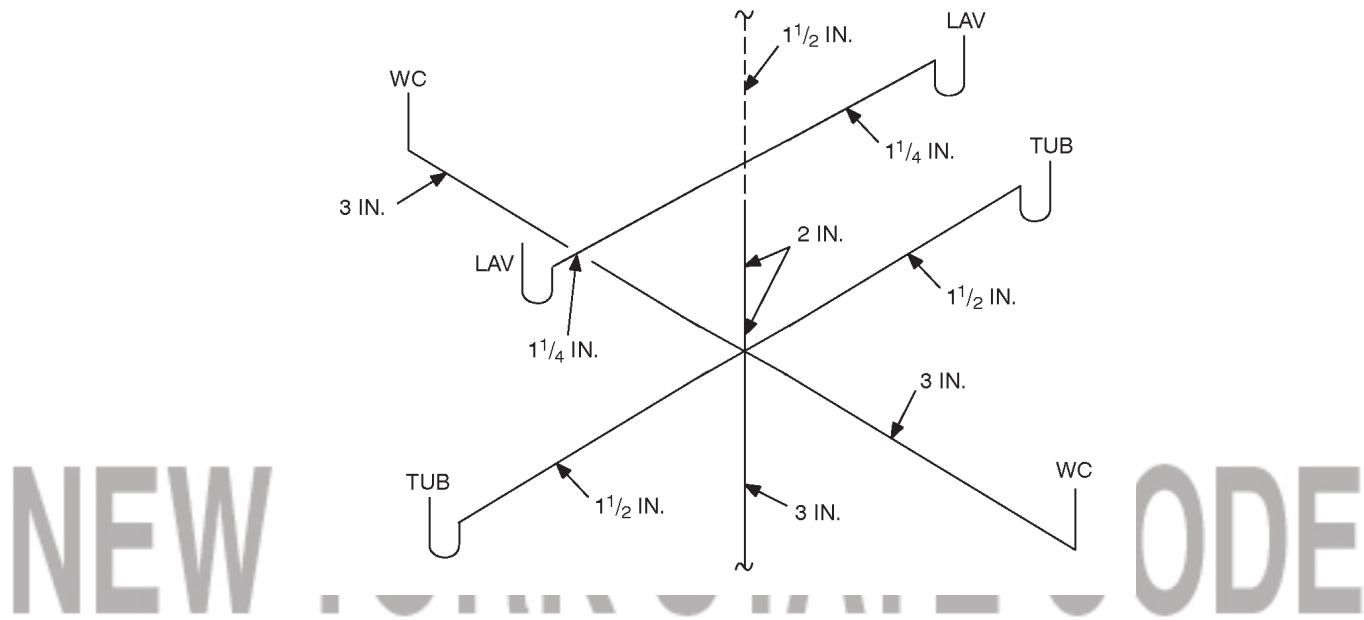

A. VERTICAL WET VENTING

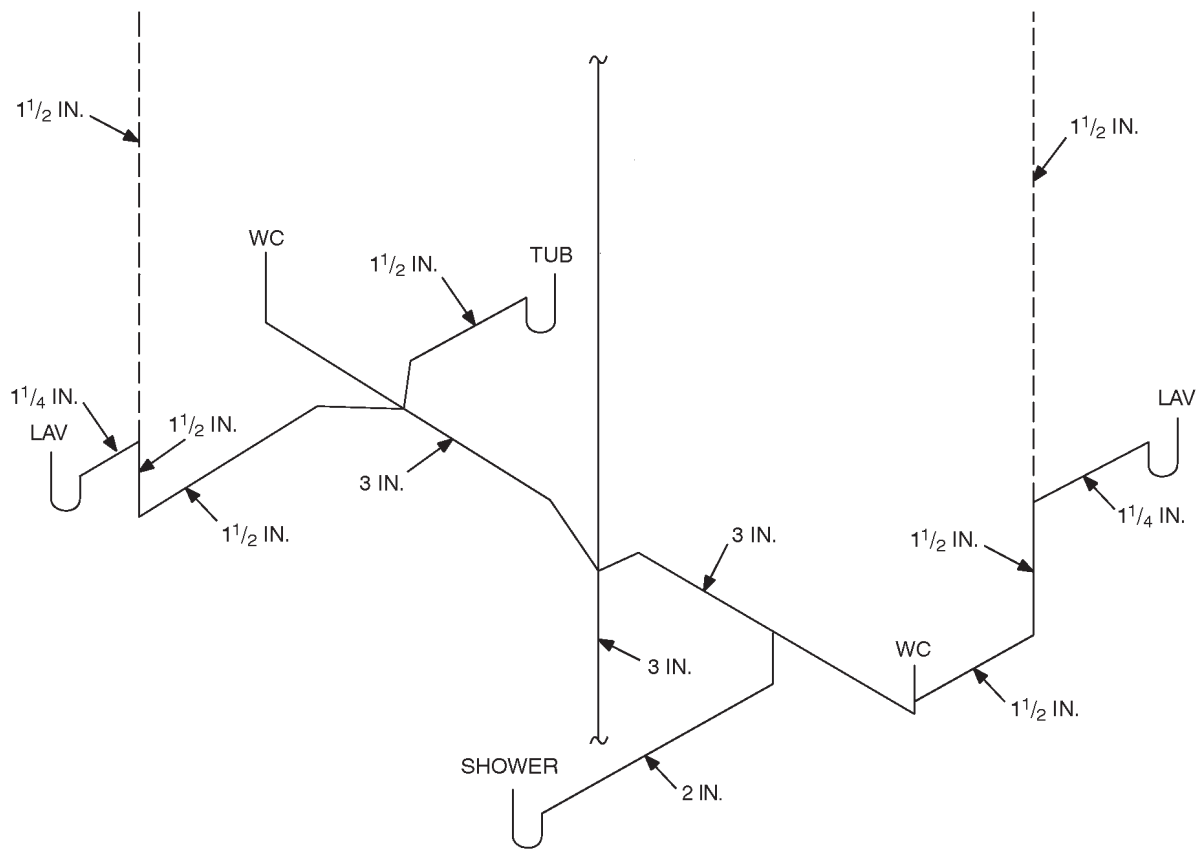

B. HORIZONTAL WET VENTING

For SI: 1 inch = 25.4 mm.

NOTE: This figure is for illustration purposes only and the written text shall apply.

FIGURE P3108.1(4)
TYPICAL METHODS OF WET VENTING

VENTS

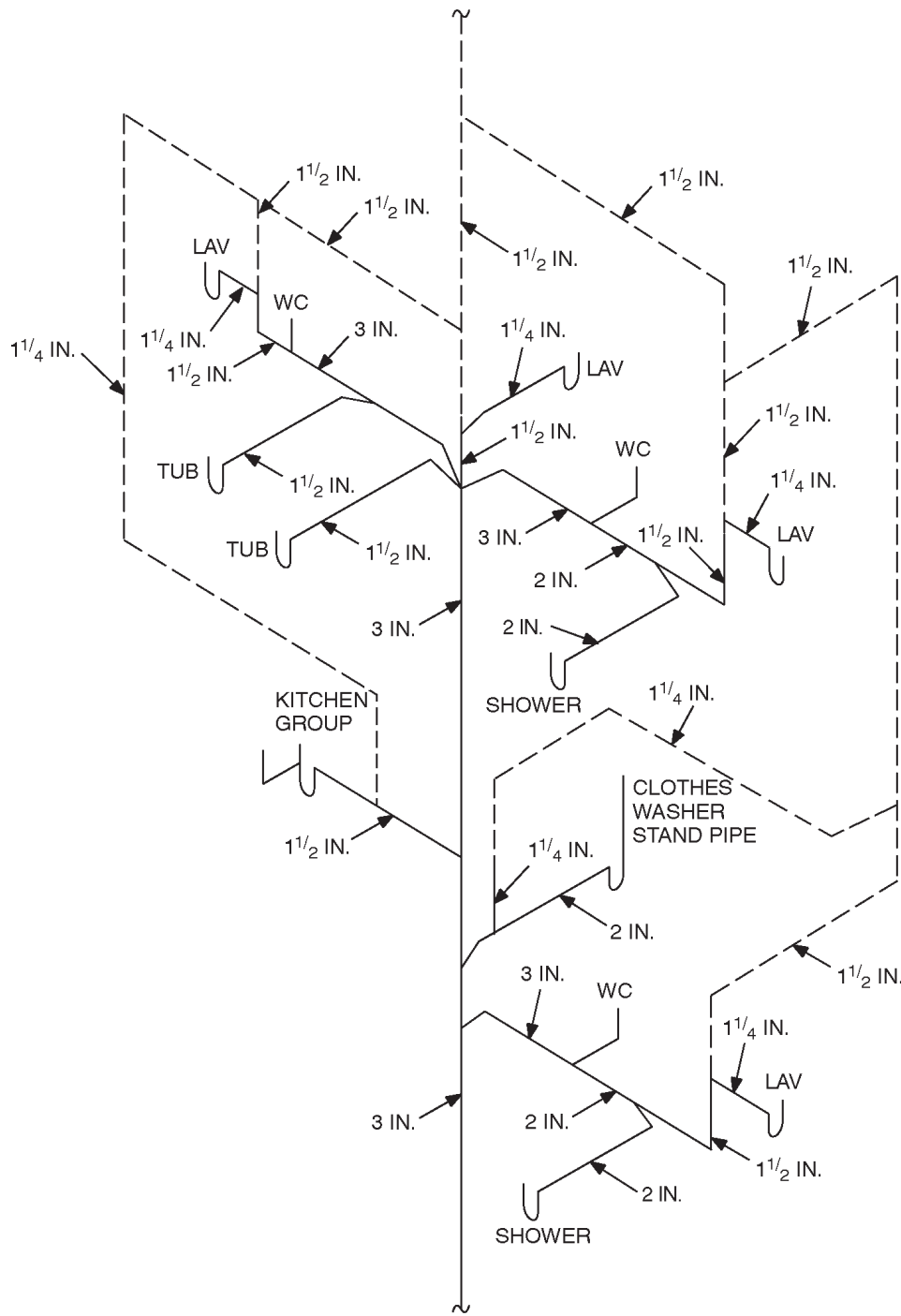

For SI: 1 inch = 25.4 mm.

NOTE: This figure is for illustration purposes only and the written text shall apply.

FIGURE P3108.1(5)
SINGLE-STACK SYSTEM FOR A TWO-STORY DWELLING

NEW YORK
31

CODE
T

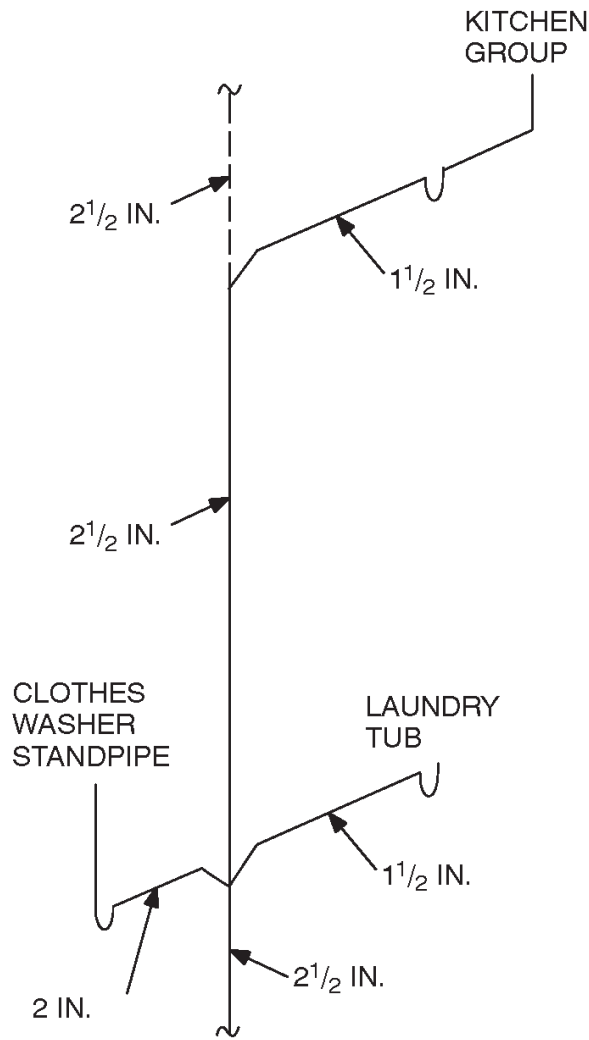

For SI: 1 inch = 25.4 mm.

NOTE: This figure is for illustration purposes only and the written text shall apply.

COPYRIGHT © ICC 2005

**FIGURE P3109.2
WET STACK VENTING**

VENTS

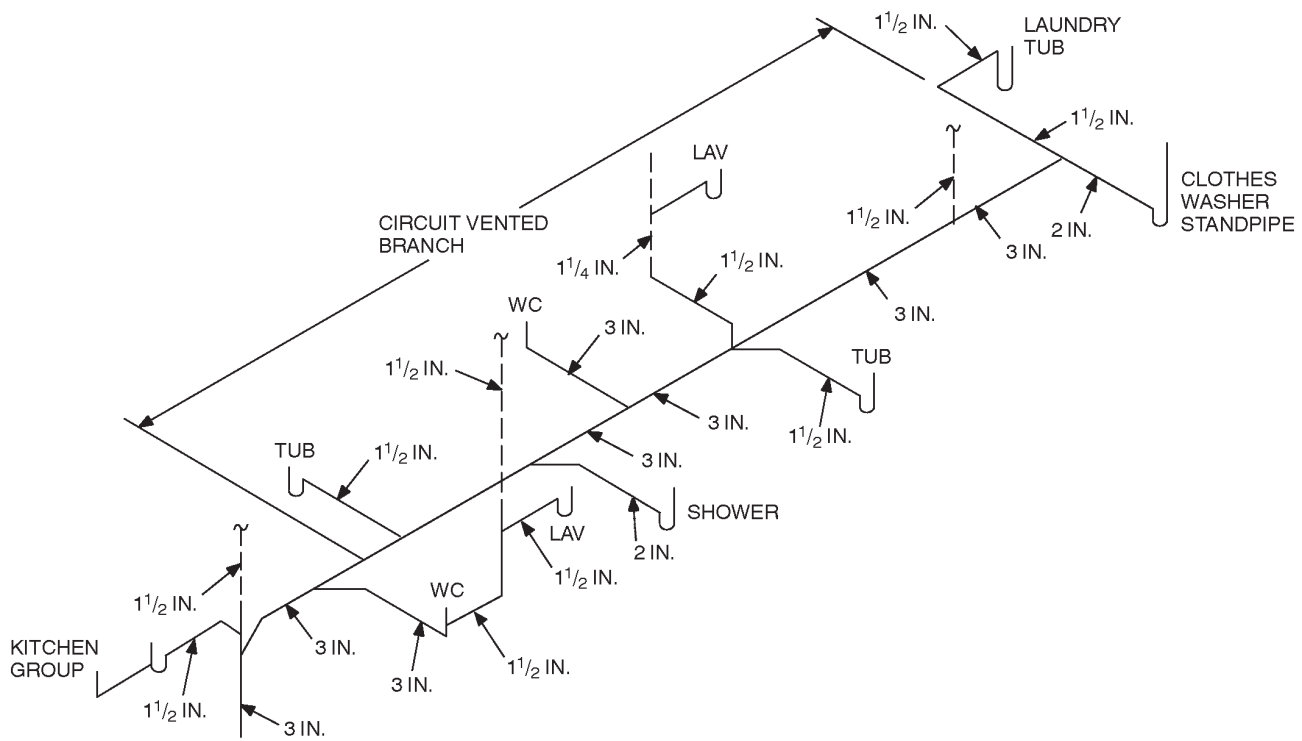

For SI: 1 inch = 25.4 mm.

NOTE: This figure is for illustration purposes only and the written text shall apply.

FIGURE P3110.4
CIRCUIT VENT WITH ADDITIONAL NONCIRCUIT VENTED BRANCHES