

CHAPTER 7 WALL COVERING

SECTION R701 GENERAL

R701.1 Application. The provisions of this chapter shall control the design and construction of the interior and exterior wall covering for all buildings.

R701.2 Installation. Products sensitive to adverse weather shall not be installed until adequate weather protection for the installation is provided. Exterior sheathing shall be dry before applying exterior cover.

SECTION R702 INTERIOR COVERING

R702.1 General. Interior coverings or wall finishes shall be installed in accordance with this chapter and Tables R702.1(1), Table R702.1(2), Table R702.1(3) and Table R702.3.5. Interior masonry veneer shall comply with the requirements of Section R703.7.1 for support and Section R703.7.4 for anchorage, except an air space is not required. Interior finishes and materials shall conform to the flame spread and smoke-density requirements of Section R315.

**TABLE R702.1(1)
THICKNESS OF PLASTER**

PLASTER BASE	FINISHED THICKNESS OF PLASTER FROM FACE OF LATH, MASONRY, CONCRETE (inches)	
	Gypsum plaster	Portland cement mortar
Expanded metal lath	$\frac{5}{8}$, minimum ^a	$\frac{5}{8}$, minimum ^a
Wire lath	$\frac{5}{8}$, minimum ^a	$\frac{3}{4}$, minimum (interior) ^b $\frac{7}{8}$, minimum (exterior) ^b
Gypsum lath ^g	$\frac{1}{2}$, minimum	$\frac{3}{4}$, minimum (interior) ^b
Masonry walls ^c	$\frac{1}{2}$, minimum	$\frac{1}{2}$, minimum
Monolithic concrete walls ^{c,d}	$\frac{5}{8}$, maximum	$\frac{7}{8}$, maximum
Monolithic concrete ceilings ^{c,d}	$\frac{3}{8}$, maximum ^e	$\frac{1}{2}$, maximum
Gypsum veneer base ^{f,g}	$\frac{1}{16}$, minimum	$\frac{3}{4}$, minimum (interior) ^b
Gypsum sheathing ^g	—	$\frac{3}{4}$, minimum (interior) ^b $\frac{7}{8}$, minimum (exterior) ^b

For SI: 1 inch = 25.4 mm.

- a. When measured from back plane of expanded metal lath, exclusive of ribs, or self-furring lath, plaster thickness shall be $\frac{3}{4}$ inch minimum.
- b. When measured from face of support or backing.
- c. Because masonry and concrete surfaces may vary in plane, thickness of plaster need not be uniform.
- d. When applied over a liquid bonding agent, finish coat may be applied directly to concrete surface.
- e. Approved acoustical plaster may be applied directly to concrete or over base coat plaster, beyond the maximum plaster thickness shown.
- f. Attachment shall be in accordance with Table R702.3.5.
- g. Where gypsum board is used as a base for portland cement plaster, weather-resistant sheathing paper complying with Section R703.2 shall be provided.

**TABLE R702.1(2)
GYPSUM PLASTER PROPORTIONS^a**

NUMBER	COAT	PLASTER BASE OR LATH	MAXIMUM VOLUME AGGREGATE PER 100 POUNDS NEAT PLASTER ^b (cubic feet)	
			Damp loose sand ^c	Perlite or vermiculite ^c
Two-coat work	Base coat	Gypsum lath	2.5	2
	Base coat	Masonry	3	3
Three-coat work	First coat	Lath	2 ^d	2
	Second coat	Lath	3 ^d	2 ^e
	First and second coats	Masonry	3	3

For SI: 1 inch = 25.4 mm, 1 cubic foot = 0.0283 m³, 1 pound = 0.454 kg.

- a. Wood-fibered gypsum plaster may be mixed in the proportions of 100 pounds of gypsum to not more than 1 cubic foot of sand where applied on masonry or concrete.
- b. When determining the amount of aggregate in set plaster, a tolerance of 10 percent shall be allowed.
- c. Combinations of sand and lightweight aggregate may be used, provided the volume and weight relationship of the combined aggregate to gypsum plaster is maintained.
- d. If used for both first and second coats, the volume of aggregate may be 2.5 cubic feet.
- e. Where plaster is 1 inch or more in total thickness, the proportions for the second coat may be increased to 3 cubic feet.

TABLE R702.1(3)
PORTLAND CEMENT PLASTER

Coat	MAXIMUM VOLUME AGGREGATE PER VOLUME CEMENTITIOUS MATERIAL ^a				MINIMUM PERIOD MOIST COATS	MINIMUM INTERVAL BETWEEN
	Portland cement plaster ^b maximum volume aggregate per volume cement	Portland cement-lime plaster ^c				
		Maximum volume lime per volume cement	Maximum volume sand per volume cement and lime	Approximate minimum thickness ^d curing (inches)		
First	4	$\frac{3}{4}$	4	$\frac{3}{8}$ ^e	48 Hours ^f	48 Hours ^g
Second	5	$\frac{3}{4}$	5	First and second coats	48 Hours	7 Days ^h
Finished	3 ⁱ	—	3 ⁱ	$\frac{1}{8}$	—	Note ^h

For SI: 1 inch = 25.4 mm, 1 pound = 0.454 kg.

- When determining the amount of aggregate in set plaster, a tolerance of 10 percent may be allowed.
- From 10 to 20 pounds of dry hydrated lime (or an equivalent amount of lime putty) may be added as a plasticizing agent to each sack of Type I and Type II standard portland cement in base coat plaster.
- No additions of plasticizing agents shall be made.
- See Table R702.1(1).
- Measured from face of support or backing to crest of scored plaster.
- Twenty-four-hour minimum period for moist curing of interior portland cement plaster.
- Twenty-four hour minimum interval between coats of interior portland cement plaster.
- Finish coat plaster may be applied to interior portland cement base coats after a 48-hour period.
- For finish coat, plaster up to an equal part of dry hydrated lime by weight (or an equivalent volume of lime putty) may be added to Type I, Type II and Type III standard portland cement.

R702.2 Interior plaster. Gypsum plaster or portland cement plastering materials shall conform to ASTM C 5, C 28, C 35, C 37, C 59, C 61, C 587, C 588, C 631, C 847, C 897, C 933, C 1032 and C 1047, and shall be installed or applied in conformance with ASTM C 843, C 844 and C 1063. Plaster shall not be less than three coats when applied over metal lath and not less than two coats when applied over other bases permitted by this section, except that veneer plaster may be applied in one coat not to exceed $\frac{3}{16}$ inch (4.76 mm) thickness, provided the total thickness is as set forth in Table R702.1(1).

R702.2.1 Support. Support spacing for gypsum or metal lath on walls or ceilings shall not exceed 16 inches (406 mm) for $\frac{3}{8}$ inch thick (9.5 mm) or 24 inches (610 mm) for $\frac{1}{2}$ -inch-thick (12.7 mm) plain gypsum lath. Gypsum lath shall be installed at right angles to support framing with end joints in adjacent courses staggered by at least one framing space.

R702.3 Gypsum board.

R702.3.1 Materials. All gypsum board materials and accessories shall conform to ASTM C 36, C 79, C 475, C 514, C 630, C 931, C 960, C 1002, C 1047, C 1177, C 1178, C 1278, C 1395 or C 1396 and shall be installed in accordance with the provisions of this section. Adhesives for the installation of gypsum board shall conform to ASTM C 557.

R702.3.2 Wood framing. Wood framing supporting gypsum board shall not be less than 2 inches (51 mm) nominal thickness in the least dimension except that wood furring strips not less than 1-inch-by-2 inch (25.4 mm by 51 mm) nominal dimension may be used over solid backing or framing spaced not more than 24 inches (610 mm) on center.

R702.3.3 Steel framing. Steel framing supporting gypsum board shall not be less than 1.25 inches (32 mm) wide in the least dimension. Light-gage nonload-bearing steel framing shall comply with ASTM C 645. Load-bearing steel framing and steel framing from 0.033 inch to 0.112 inch (0.838 mm to 2.84 mm) thick shall comply with ASTM C 955.

R702.3.4 Insulating concrete form walls. Foam plastics for insulating concrete form walls constructed in accordance with Sections R404.4 and R611 on the interior of habitable spaces shall be covered in accordance with Section R314.1.2. Adhesives are permitted to be used in conjunction with mechanical fasteners. Adhesives used for interior and exterior finishes shall be compatible with the insulating form materials.

R702.3.5 Application. Maximum spacing of supports and the size and spacing of fasteners used to attach gypsum board shall comply with Table R702.3.5. Gypsum sheathing shall be attached to exterior walls in accordance with Table R602.3(1). Gypsum board shall be applied at right angles or parallel to framing members. All edges and ends of gypsum board shall occur on the framing members, except those edges and ends that are perpendicular to the framing members. Interior gypsum board shall not be installed where it is directly exposed to the weather or to water.

R702.3.6 Fastening. Screws for attaching gypsum board to wood framing shall be Type W or Type S in accordance with ASTM C 1002 and shall penetrate the wood not less than $\frac{5}{8}$ inch (15.9 mm). Screws for attaching gypsum board to light-gage steel framing shall be Type S in accordance with ASTM C 1002 and shall penetrate the steel not less than $\frac{3}{8}$ inch (9.5 mm). Screws for attaching gypsum board to steel framing 0.033 inch to 0.112 inch (0.838 mm to 2.84 mm) thick shall comply with ASTM C 954.

TABLE R702.3.5
MINIMUM THICKNESS AND APPLICATION OF GYPSUM BOARD

THICKNESS OF GYPSUM BOARD (inches)	APPLICATION	ORIENTATION OF GYPSUM BOARD TO FRAMING	MAXIMUM SPACING OF FRAMING MEMBERS (inches o.c.)	MAXIMUM SPACING OF FASTENERS (inches)		SIZE OF NAILS FOR APPLICATION TO WOOD FRAMING ^c
				Nails ^a	Screws ^b	
Application without adhesive						
3/8	Ceiling ^d	Perpendicular	16	7	12	13 gage, 1 1/4" long, 19/64" head; 0.098" diameter, 1 1/4" long, annular-ringed; or 4d cooler nail, 0.080" diameter, 1 3/8" long, 7/32" head.
	Wall	Either direction	16	8	16	
1/2	Ceiling	Either direction	16	7	12	13 gage, 1 3/8" long, 19/64" head; 0.098" diameter, 1 1/4" long, annular-ringed; 5d cooler nail, 0.086" diameter, 1 5/8" long, 15/64" head; or gypsum board nail, 0.086" diameter, 1 3/8" long, 9/32" head.
	Ceiling ^d	Perpendicular	24	7	12	
	Wall	Either direction	24	8	12	
	Wall	Either direction	16	8	16	
5/8	Ceiling	Either direction	16	7	12	13 gage, 1 5/8" long, 19/64" head; 0.098" diameter, 1 3/8" long, annular-ringed; 6d cooler nail, 0.092" diameter, 1 7/8" long, 1/4" head; or gypsum board nail, 0.0915" diameter, 1 7/8" long, 19/64" head.
	Ceiling ^e	Perpendicular	24	7	12	
	Wall	Either direction	24	8	12	
	Wall	Either direction	16	8	16	
Application with adhesive						
3/8	Ceiling ^d	Perpendicular	16	16	16	Same as above for 3/8" gypsum board
	Wall	Either direction	16	16	24	
1/2 or 5/8	Ceiling	Either direction	16	16	16	Same as above for 1/2" and 5/8" gypsum board, respectively
	Ceiling ^d	Perpendicular	24	12	16	
	Wall	Either direction	24	16	24	
Two 3/8 layers	Ceiling	Perpendicular	16	16	16	Base ply nailed as above for 1/2" gypsum board; face ply installed with adhesive
	Wall	Either direction	24	24	24	

For SI: 1 inch = 25.4 mm.

- a. For application without adhesive, a pair of nails spaced not less than 2 inches apart or more than 2 1/2 inches apart may be used with the pair of nails spaced 12 inches on center.
- b. Screws shall be Type S or W per ASTM C 1002 and shall be sufficiently long to penetrate wood framing not less than 5/8 inch and metal framing not less than 3/8 inch.
- c. Where metal framing is used with a clinching design to receive nails by two edges of metal, the nails shall be not less than 5/8 inch longer than the gypsum board thickness and shall have ringed shanks. Where the metal framing has a nailing groove formed to receive the nails, the nails shall have barbed shanks or be 5d, 13 1/2 gage, 1 5/8 inches long, 1 5/64-inch head for 1/2-inch gypsum board; and 6d, 13 gage, 1 1/8 inches long, 1 5/64-inch head for 3/8-inch gypsum board.
- d. Three-eighths-inch-thick single-ply gypsum board shall not be used on a ceiling where a water-based textured finish is to be applied, or where it will be required to support insulation above a ceiling. On ceiling applications to receive a water-based texture material, either hand or spray applied, the gypsum board shall be applied perpendicular to framing. When applying a water-based texture material, the minimum gypsum board thickness shall be increased from 3/8 inch to 1/2 inch for 16-inch on center framing, and from 1/2 inch to 5/8 inch for 24-inch on center framing or 1/2-inch sag-resistant gypsum ceiling board shall be used.
- e. Type X gypsum board for garage ceilings beneath habitable rooms shall be installed perpendicular to the ceiling framing and shall be fastened at maximum 6 inches o.c. by minimum 1 7/8 inches 6d coated nails or equivalent drywall screws.

R702.4 Ceramic tile.

R702.4.1 General. Ceramic tile surfaces shall be installed in accordance with ANSI A108.1, A108.4, A108.5, A108.6, A108.11, A118.1, A118.3, A136.1 and A137.1.

R702.4.2 Gypsum backer. Gypsum board utilized as the base or backer for adhesive application of ceramic tile or other nonabsorbent finish material shall conform with ASTM C630 or C1178. Water-resistant gypsum backing board shall be permitted to be used on ceilings where framing spacing does not exceed 12 inches (305 mm) on center for 1/2-inch-thick (12.7 mm) or 16 inches (406 mm) for 5/8 inch-thick (15.9 mm) gypsum board. Water-resistant gypsum board shall not be installed over a vapor retarder in a shower or tub compartment. All cut or exposed edges, in-

cluding those at wall intersections, shall be sealed as recommended by the manufacturer.

R702.4.3 Limitations. Water-resistant gypsum backing board shall not be used in the following locations:

1. Over a vapor retarder in a shower or bathtub compartment.
2. Where there will be direct exposure to water, or in areas subject to continuous high humidity.

R702.5 Other finishes. Wood veneer paneling and hardboard paneling shall be placed on wood or cold-formed steel framing spaced not more than 16 inches (406 mm) on center. Wood veneer and hard board paneling less than 1/4 inch (6.4 mm) nominal thickness shall not have less than a 3/8-inch (9.5 mm) gypsum board backer. Wood veneer paneling not less than 1/4-inch (6.4 mm) nominal thickness shall conform to

WALL COVERING

ANSI/HPVA HP-1. Hardboard paneling shall conform to ANSI/AHA A135.5.

R702.6 Wood shakes and shingles. Wood shakes and shingles shall conform to CSSB *Grading Rules for Wood Shakes and Shingles* and shall be permitted to be installed directly to the studs with maximum 24 inches (610 mm) on center spacing.

R702.6.1 Attachment. Nails, staples or glue are permitted for use in attaching shakes or shingles to the wall, and the shakes or shingles shall be permitted to be attached directly to the surface provided the fasteners are appropriate for the type of wall surface material. When nails or staples are used, two fasteners shall be provided and shall be placed so that they are covered by the course above.

R702.6.2 Furring strips. Where furring strips are used, they shall be 1 inch by 2 inches or 1 inch by 3 inches (25.4 mm by 51 mm or 25.4 mm by 76 mm), spaced a distance on center equal to the desired exposure, and shall be attached to the wall by nailing through other wall material into the studs.

SECTION R703 EXTERIOR COVERING

R703.1 General. Exterior walls shall provide the building with a weather-resistant exterior wall envelope. The exterior wall envelope shall include flashing as described in Section R703.8. The exterior wall envelope shall be designed and constructed in such a manner as to prevent the accumulation of water within the wall assembly by providing a water-resistive barrier behind the exterior veneer as required by Section R703.2.

R703.2 Weather-resistant sheathing paper. Asphalt-saturated felt free from holes and breaks, weighing not less than 14 pounds per 100 square feet (0.683 kg/m²) and complying with ASTM D 226 or other approved weather-resistant material shall be applied over studs or sheathing of all exterior walls as required by Table R703.4. Such felt or material shall be applied horizontally, with the upper layer lapped over the lower layer not less than 2 inches (51 mm). Where joints occur, felt shall be lapped not less than 6 inches (152 mm).

Exception: Such felt or material is permitted to be omitted in the following situations:

1. In detached accessory buildings.
2. Under panel siding with shiplap joints or battens.
3. Under exterior wall finish materials as permitted in Table R703.4.
4. Under paperbacked stucco lath.

R703.3 Wood, hardboard and wood structural panel siding.

R703.3.1 Panel siding. Joints in wood, hardboard or wood structural panel siding shall be made as follows unless otherwise approved. Vertical joints in panel siding shall occur over framing members, unless wood or wood structural panel sheathing is used, and shall be shiplapped or covered with a batten. Horizontal joints in panel siding shall be lapped a minimum of 1 inch (25.4 mm) or shall be shiplapped or shall be flashed with Z-flashing and occur

over solid blocking, wood or wood structural panel sheathing.

R703.3.2 Horizontal siding. Horizontal lap siding shall be lapped a minimum of 1 inch (25.4 mm), or 0.5 inch (12.7 mm) if rabbeted, and shall have the ends caulked, covered with a batten, or sealed and installed over a strip of flashing.

R703.4 Attachments. Unless specified otherwise, all wall coverings shall be securely fastened in accordance with Table R703.4 or with other approved aluminum, stainless steel, zinc-coated or other approved corrosion-resistive fasteners.

R703.5 Wood shakes and shingles. Wood shakes and shingles shall conform to CSSB *Grading Rules for Wood Shakes and Shingles*.

R703.5.1 Application. Wood shakes or shingles shall be applied either single-course or double-course over nominal 1/2-inch (12.7 mm) wood-based sheathing or to furring strips over 1/2-inch (12.7 mm) nominal nonwood sheathing. A weather-resistant permeable membrane shall be provided over all sheathing, with horizontal overlaps in the membrane of not less than 2 inches (51 mm) and vertical overlaps of not less than 6 inches (152 mm). Where furring strips are used, they shall be 1 inch by 3 inches or 1 inch by 4 inches (25.4 mm by 76 mm or 25.4 mm by 102 mm) and shall be fastened horizontally to the studs with 7d or 8d box nails and shall be spaced a distance on center equal to the actual weather exposure of the shakes or shingles, not to exceed the maximum exposure specified in Table R703.5.2. The spacing between adjacent shingles to allow for expansion shall not exceed 1/4 inch (6.4 mm), and between adjacent shakes, it shall not exceed 1/2 inch (12.7 mm). The offset spacing between joints in adjacent courses shall be a minimum of 1 1/2 inches (38 mm).

R703.5.2 Weather exposure. The maximum weather exposure for shakes and shingles shall not exceed that specified in Table R703.5.2.

R703.5.3 Attachment. Each shake or shingle shall be held in place by two hot-dipped zinc-coated, stainless steel, or aluminum nails or staples. The fasteners shall be long enough to penetrate the sheathing or furring strips by a minimum of 1/2 inch (12.7 mm) and shall not be overdriven.

R703.5.3.1 Staple attachment. Staples shall not be less than 16 gage and shall have a crown width of not less than 7/16 inch (11.1 mm), and the crown of the staples shall be parallel with the butt of the shake or shingle. In single-course application, the fasteners shall be concealed by the course above and shall be driven approximately 1 inch (25.4 mm) above the butt line of the succeeding course and 3/4 inch (19.1 mm) from the edge. In double-course applications, the exposed shake or shingle shall be face-nailed with two casing nails, driven approximately 2 inches (51 mm) above the butt line and 3/4 inch (19.1 mm) from each edge. In all applications, staples shall be concealed by the course above. With shingles wider than 8 inches (203 mm) two additional nails shall be required and shall be nailed approximately 1 inch (25.4 mm) apart near the center of the shingle.

**TABLE R703.4
WEATHER-RESISTANT SIDING ATTACHMENT AND MINIMUM THICKNESS**

SIDING MATERIAL		NOMINAL THICKNESS ^a (inches)	JOINT TREATMENT	SHEATHING PAPER REQUIRED	TYPE OF SUPPORTS FOR THE SIDING MATERIAL AND FASTENERS ^{b,c,d}					
					Wood or wood structural panel sheathing	Fiberboard sheathing into stud	Gypsum sheathing into stud	Foam plastic sheathing into stud	Direct to studs	Number or spacing of fasteners
Horizontal aluminum ^c	Without insulation	0.019 ^f	Lap	No	0.120 nail 1 1/2" long	0.120 nail 2" long	0.120 nail 2" long	0.120 nail ^z	Not allowed	Same as stud spacing
		0.024	Lap	No	0.120 nail 1 1/2" long	0.120 nail 2" long	0.120 nail 2" long	0.120 nail ^z	Not allowed	
	With insulation	0.019	Lap	No	0.120 nail 1 1/2" long	0.120 nail 2 1/2" long	0.120 nail 2 1/2" long	0.120 nail ^z	0.120 nail 1 1/2" long	
Brick veneer Concrete masonry veneer		2 2	Section R703	Yes (Note m)	See Section R703 and Figure R703.7 ^h					
Hardboard ^l Panel siding-vertical		7/16	Note g	See R703.2	Note o	Note o	Note o	Note o	Note o	6" panel edges 12" inter. sup. ^p
Hardboard ^l Siding vertical		7/16	Note g	See R703.2	Note q	Note q	Note q	Note q	Note q	Same as stud spacing 2 per bearing
Hardboard ^l Lap-siding-horizontal		7/16	Note r	Yes	Note q	Note q	Note q	Note q	Note q	
Steel ^l		29 ga.	Lap	No	0.113 nail 1 3/4" Staple-1 3/4"	0.113 nail 2 3/4" Staple-2 1/2"	0.113 nail 2 1/2" Staple-2 1/4"	0.113 nail ^z Staple ^z	Not allowed	Same as stud spacing
Stone veneer		2	Section R703	Yes (Note m)	See Section R703 and Figure R703.7 ^h					
Particleboard panels		3/8 - 1/2	Note g	Note g	6d box nail	6d box nail	6d box nail	box nail ^z	6d box nail, 3/8 not allowed	6" panel edge 12" inter. sup.
		5/8	Note g	Note g	6d box nail	8d box nail	8d box nail	box nail ^z	6d box nail	
Plywood panel ^l (exterior grade)		3/8	Note g	Note g	0.099 nail-2"	0.113 nail-2 1/2"	0.099 nail-2"	0.113 nail ^z	0.099 nail-2"	6" on edges
Vinyl siding ^q		0.035	Lap	No	0.120 nail 1 1/2" Staple-1 3/4"	0.120 nail 2" Staple-2 1/2"	0.120 nail 2" Staple-2 1/2"	0.120 nail ^z Staple ^z	Not allowed	Same as stud spacing
Wood ^k Rustic, drop		3/8 Min	Lap	No	Fastener penetration into stud-1"				0.113 nail-2 1/2" Staple-2"	Face nailing up to 6" widths, 1 nail per bearing; 8" widths and over, 2 nails per bearing
Shiplap		19/32 Average	Lap	No						
Bevel		7/16	Lap	No						
Butt tip		3/16	Lap	No						
Fiber cement panel siding ^s		5/16	Note t	Yes Note y	6d corrosion resistant nail ^u	6d corrosion resistant nail ^u	6d corrosion resistant nail ^u	—	4d corrosion resistant nail ^v	6" oc on edges, 12" oc on intermed. studs
Fiber cement lap siding ^s		5/16	Note w	Yes Note y	6d corrosion resistant nail ^u	6d corrosion resistant nail ^u	6d corrosion resistant nail ^u	—	6d corrosion resistant nail ^x	Note x

For SI: 1 inch = 25.4 mm.

- a. Based on stud spacing of 16 inches on center. Where studs are spaced 24 inches, siding shall be applied to sheathing approved for that spacing.
- b. Nail is a general description and shall be T-head, modified round head, or round head with smooth or deformed shanks.
- c. Staples shall have a minimum crown width of 7/16-inch outside diameter and be manufactured of minimum No. 16 gage wire.
- d. Nails or staples shall be aluminum, galvanized, or rust-preventive coated and shall be driven into the studs for fiberboard or gypsum backing.
- e. Aluminum nails shall be used to attach aluminum siding.
- f. Aluminum (0.019 inch) shall be unbacked only when the maximum panel width is 10 inches and the maximum flat area is 8 inches. The tolerance for aluminum siding shall be +0.002 inch of the nominal dimension.
- g. If boards or panels are applied over sheathing or a weather-resistant membrane, joints need not be treated. Otherwise, vertical joints shall occur at studs and be covered with battens or be lapped.
- h. All attachments shall be coated with a corrosion-resistant coating.
- i. Shall be of approved type.

(continued)

WALL COVERING

Footnotes to Table R703.4—continued

- j. Three-eighths-inch plywood shall not be applied directly to studs spaced greater than 16 inches on center when long dimension is parallel to studs. One-half-inch plywood shall not be applied directly to studs spaced greater than 24 inches on center. The stud spacing shall not exceed the panel span rating provided by the manufacturer unless the panels are installed with the face grain perpendicular to studs or over sheathing approved for that stud spacing.
- k. Woodboard sidings applied vertically shall be nailed to horizontal nailing strips or blocking set 24 inches on center. Nails shall penetrate 1.5 inches into studs, studs and wood sheathing combined, or blocking. A weather-resistant membrane shall be installed weatherboard fashion under the vertical siding unless the siding boards are lapped or battens are used.
- l. Hardboard siding shall comply with AHA A135.6.
- m. For masonry veneer, a weather-resistant membrane or building paper is not required over water-repellent sheathing materials when a 1-inch air space is provided between the veneer and the sheathing. When the 1-inch space is filled with mortar, a weather-resistant membrane or building paper is required over studs or sheathing.
- n. Vinyl siding shall comply with ASTM D 3679.
- o. Minimum shank diameter of 0.092 inch, minimum head diameter of 0.225 inch, and nail length must accommodate sheathing and penetrate framing 1.5 inches.
- p. When used to resist shear forces, the spacing must be 4 inches at panel edges and 8 inches on interior supports.
- q. Minimum shank diameter of 0.099 inch, minimum head diameter of 0.240 inch, and nail length must accommodate sheathing and penetrate framing 1.5 inches.
- r. Vertical end joints shall occur at studs and shall be covered with a joint cover or shall be caulked.
- s. Fiber cement siding shall comply with the requirements of ASTM C 1186.
- t. See Section R703.10.1.
- u. Minimum 0.102 inch smooth shank, 0.255 inch round head.
- v. Minimum 0.099 inch smooth shank, 0.250 inch round head.
- w. See Section R703.10.2.
- x. Face nailing: 2 nails at each stud. Concealed nailing: one 11 gage 1½ galv. roofing nail (0.371 inch head diameter, 0.120 inch shank) or 6d galv. box nail at each stud.
- y. See Section R703.2, Exceptions.
- z. Minimum nail length must accommodate sheathing and penetrate framing 1.5 inches.

TABLE R703.5.2
MAXIMUM WEATHER EXPOSURE FOR WOOD SHAKES AND SHINGLES ON EXTERIOR WALLS^{a,b,c}
 (Dimensions are in inches)

LENGTH	EXPOSURE FOR SINGLE COURSE	EXPOSURE FOR DOUBLE COURSE
Shingles ^a		
16	7½	12 ^b
18	8½	14 ^c
24	11½	16
Shakes ^a		
18	8½	14
24	11½	18

For SI: 1 inch = 25.4 mm.

- a. Dimensions given are for No. 1 grade.
- b. A maximum 10-inch exposure is permitted for No. 2 grade.
- c. A maximum 11-inch exposure is permitted for No. 2 grade.

R703.5.4 Bottom courses. The bottom courses shall be doubled.

R703.6 Exterior plaster.

R703.6.1 Lath. All lath and lath attachments shall be of corrosion-resistant materials. Expanded metal or woven wire lath shall be attached with 1½-inch-long (38 mm), 11 gage nails having a 7/16-inch (11.1 mm) head, or 7/8-inch-long (22.2 mm), 16 gage staples, spaced at no more than 6 inches (152 mm), or as otherwise approved.

R703.6.2 Plaster. Plastering with portland cement plaster shall be not less than three coats when applied over metal lath or wire lath and shall be not less than two coats when applied over masonry, concrete or gypsum backing. If the plaster surface is completely covered by veneer or other facing material or is completely concealed, plaster application need be only two coats, provided the total thickness is as set forth in Table R702.1(1).

On wood-frame construction with an on-grade floor slab system, exterior plaster shall be applied in such a manner as to cover, but not extend below, lath, paper and screed.

The proportion of aggregate to cementitious materials shall be as set forth in Table R702.1(3).

R703.6.2.1 Weep screeds. A minimum 0.019-inch (0.48 mm) (No. 26 galvanized sheet gage), corrosion-resistant weep screed or plastic weep screed, with a minimum vertical attachment flange of 3½ inches (89 mm) shall be provided at or below the foundation plate line on exterior stud walls in accordance with ASTM C 926. The weep screed shall be placed a minimum of 4 inches (102 mm) above the earth or 2 inches (51 mm) above paved areas and shall be of a type that will allow trapped water to drain to the exterior of the building. The weather-resistant barrier shall lap the attachment flange. The exterior lath shall cover and terminate on the attachment flange of the weep screed.

R703.7 Stone and masonry veneer, general. All stone and masonry veneer shall be installed in accordance with this chapter, Table R703.4 and Figure R703.7. Such veneers installed over a backing of wood or cold-formed steel shall be limited to the first story above grade and shall not exceed 5 inches (127 mm) in thickness.

Exceptions:

1. In Seismic Design Categories A and B, exterior masonry veneer with a backing of wood or cold-formed steel framing shall not exceed 30 feet (9144 mm) in height above the noncombustible foundation, with an additional 8 feet (2348 mm) permitted for ends.
2. In Seismic Design Category C, exterior masonry veneer with a backing of wood or cold-formed steel framing shall not exceed 30 feet (9144 mm) in height above the noncombustible foundation, with an additional 8 feet (2348 mm) permitted for gabled ends. In other than the topmost story, the length of bracing shall be 1.5 times the length otherwise required in Chapter 6.
3. For detached one- or two-family dwellings with a maximum nominal thickness of 4 inches (102 mm) of exterior masonry veneer with a backing of wood frame located in Seismic Design Category D₁, the masonry veneer shall not exceed 20 feet (6096 mm) in height above a noncombustible foundation, with an additional 8 feet (2438 mm) permitted for gabled ends, or 30 feet (9144 mm) in height with an additional 8 feet (2438 mm) permitted for gabled ends where the lower 10 feet (3048 mm) has a backing of concrete or masonry wall, provided the following criteria are met:
 - 3.1. Braced wall panels shall be constructed with a minimum of $\frac{7}{16}$ inch (11.1 mm) thick sheathing fastened with 8d common nails at 4 inches (102 mm) on center on panel edges and at 12 inches (305 mm) on center on intermediate supports.
 - 3.2. The bracing of the top story shall be located at each end and at least every 25 feet (7620 mm) on center but not less than 45% of the braced wall line. The bracing of the first story shall be as provided in Table R602.10.1.
 - 3.3. Hold down connectors shall be provided at the ends of braced walls for the second floor to first floor wall assembly with an allowable design of 2100 lbs. (952.5 kg). Hold down connectors shall be provided at the ends of each wall segment of the braced walls for the first floor to foundation assembly with an allowable design of 3700 lbs. (1678 kg). In all cases, the hold down connector force shall be transferred to the foundation.
 - 3.4. Cripple walls shall not be permitted.

4. For detached one- and two-family dwellings with a maximum actual thickness of 3 inches (76 mm) of exterior masonry veneer with a backing of wood frame located in Seismic Design Category D₂, the masonry veneer shall not exceed 20 feet (6096 mm) in height above a noncombustible foundation, with an additional 8 feet (2438 mm) permitted for gabled ends, or 30 feet (9144 mm) in height with an additional 8 feet (2438 mm) permitted for gabled ends where the lower 10 feet (3048 mm) has a backing of concrete or masonry wall, provided the following criteria are met:
 - 4.1. Braced wall panels shall be constructed with a minimum of $\frac{7}{16}$ inch (11.1 mm) thick sheathing fastened with 8d common nails at 4 inches (102 mm) on center on panel edges and at 12 inches (305 mm) on center on intermediate supports.
 - 4.2. The bracing of the top story shall be located at each end and at least every 25 feet (7620 mm) on center but not less than 55% of the braced wall line. The bracing of the first story shall be as provided in Table R602.10.1.
 - 4.3. Hold down connectors shall be provided at the ends of braced walls for the second floor to first floor wall assembly with an allowable design of 2300 lbs. (1043 kg). Hold down connectors shall be provided at the ends of each wall segment of the braced walls for the first floor to foundation assembly with an allowable design of 3900 lbs. (1769 kg). In all cases, the hold down connector force shall be transferred to the foundation.
 - 4.4. Cripple walls shall not be permitted.

R703.7.1 Interior veneer support. Veneers used as interior wall finishes shall be permitted to be supported on wood or cold-formed steel floors that are designed to support the loads imposed.

R703.7.2 Exterior veneer support. Except in Seismic Design Categories D₁ and D₂, exterior masonry veneers having an installed weight of 40 pounds per square foot (195 kg/m²) or less shall be permitted to be supported on wood or cold-formed steel construction. When masonry veneer supported by wood or cold-formed steel construction adjoins masonry veneer supported by the foundation, there shall be a movement joint between the veneer supported by the wood or cold-formed steel construction and the veneer supported by the foundation. The wood or cold-formed steel construction supporting the masonry veneer shall be designed to limit the deflection to $\frac{1}{600}$ of the span for the supporting members. The design of the wood or cold-formed steel construction shall consider the weight of the veneer and any other loads.

WALL COVERING

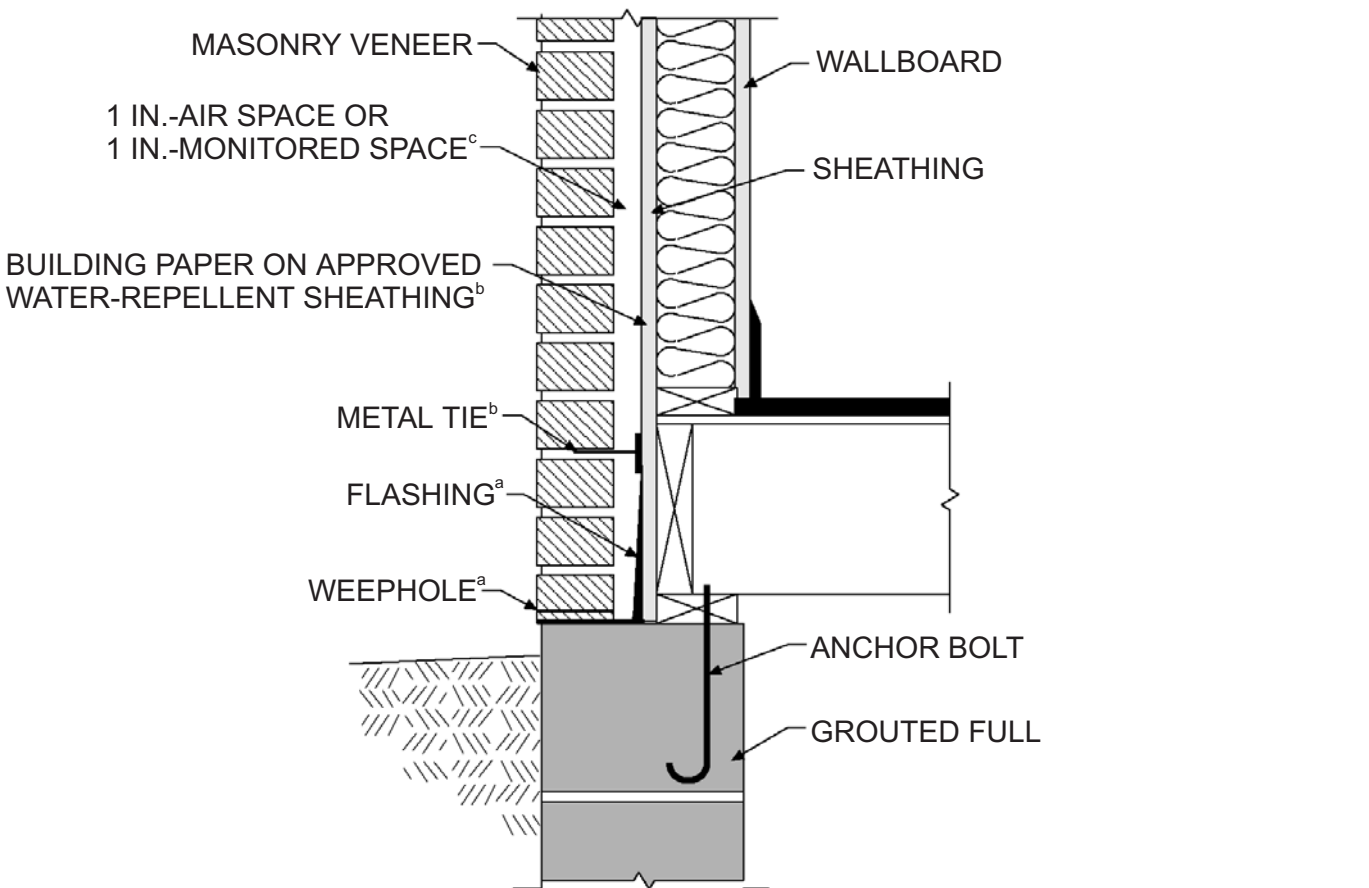
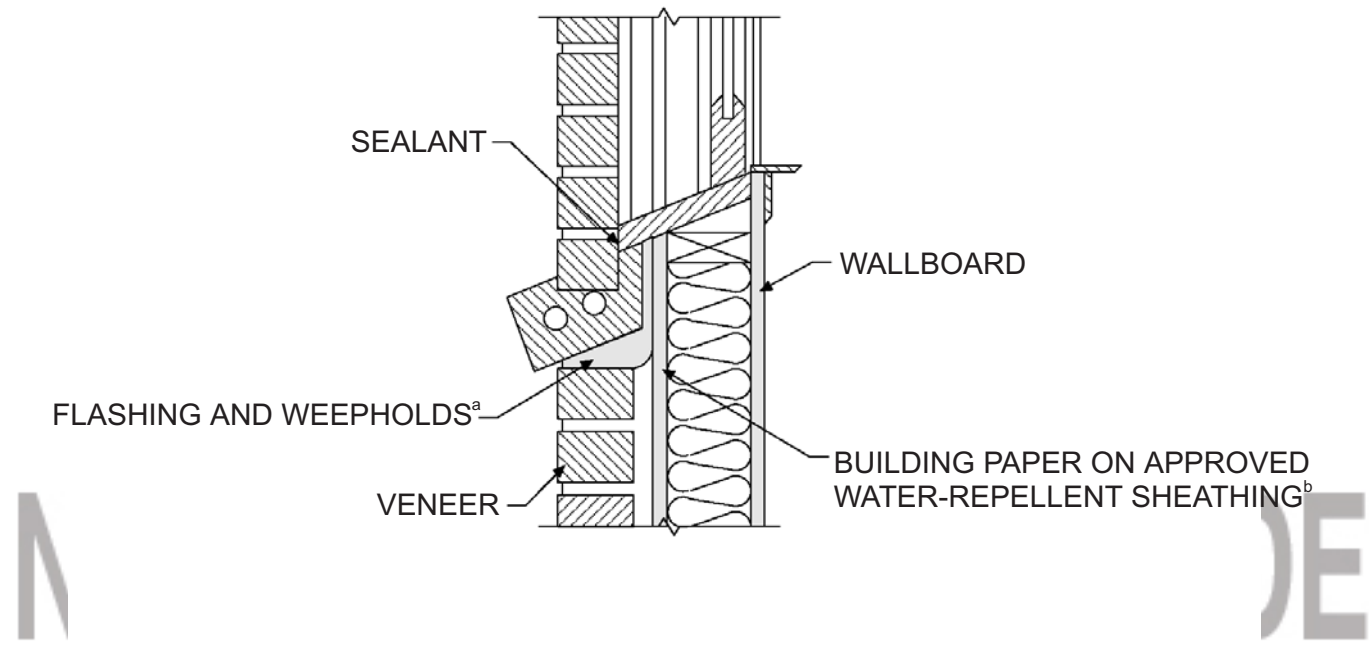

For SI: 1 inch = 25.4 mm.

FIGURE R703.7
MASONRY VENEER WALL DETAILS
(continued)

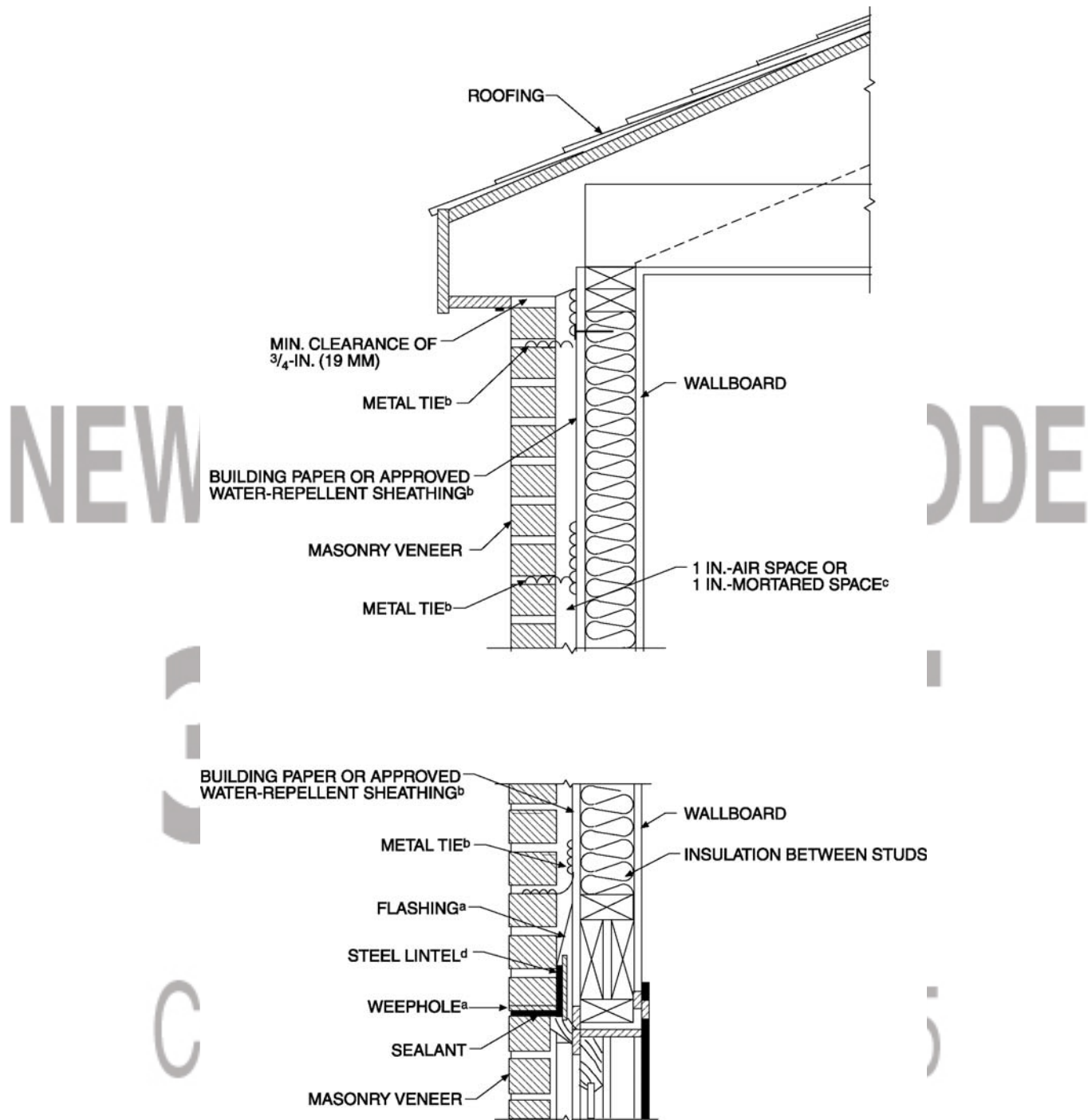

For SI: 1 inch = 25.4 mm.

a. See Sections R703.7.5, R703.7.6 and R703.8.

b. See Sections R703.2 and R703.7.4.

c. See Sections R703.7.4.2 and R703.7.4.3.

d. See Section R703.7.2.1.

**FIGURE R703.7—continued
MASONRY VENEER WALL DETAILS**

R703.7.2.1 Support by steel angle. A minimum 6 inches by 4 inches by $\frac{5}{16}$ inch (152 mm by 102 mm by 8 mm) steel angle, with the long leg placed vertically, shall be anchored to double 2 inches by 4 inches (51 mm by 102 mm) wood studs at a maximum on center spacing of 16 inches (406 mm). Anchorage of the steel angle at every double stud spacing shall be a minimum of two $\frac{7}{16}$ inch (11.1 mm) diameter by 4 inches (102 mm) lag screws. The steel angle shall have a minimum clearance to underlying construction of $\frac{1}{16}$ inch (1.6 mm). A minimum of two-thirds the width of the masonry veneer thickness shall bear on the steel angle. Flashing and weep holes shall be located in the masonry veneer wythe in accordance with Figure R703.7.1. The maximum height of masonry veneer above the steel angle support shall be 12 feet, 8 inches (3861 mm). The air space separating the masonry veneer from the wood backing shall be in accordance with R703.7.4 and R703.7.4.2. The method of support for the masonry veneer on wood construction shall be constructed in accordance with Figure R703.7.2.1.

The maximum slope of the roof construction without stops shall be 7:12. Roof construction with slopes greater than 7:12 but not more than 12:12 shall have stops of a minimum 3 inches \times 3 inches \times $\frac{1}{4}$ inch (76 mm \times 76 mm \times 6 mm) steel plate welded to the angle at 24 inches (610 mm) on center along the angle or as approved by the code enforcement official.

R703.7.2.2 Support by roof construction. A steel angle shall be placed directly on top of the roof construction. The roof supporting construction for the steel angle shall consist of a minimum of three 2-inch by 6-inch (51

mm by 152 mm) wood members. The wood member abutting the vertical wall stud construction shall be anchored with a minimum of three $\frac{5}{8}$ -inch (15.9 mm) diameter by 5-inch (127 mm) lag screws to every wood stud spacing. Each additional roof member shall be anchored by the use of two 10d nails at every wood stud spacing. A minimum of two-thirds the width of the masonry veneer thickness shall bear on the steel angle. Flashing and weep holes shall be located in the masonry veneer wythe in accordance with Figure R703.7.1. The maximum height of the masonry veneer above the steel angle support shall be 12 feet, 8 inches (3861 mm). The air space separating the masonry veneer from the wood backing shall be in accordance with R703.7.4 and R703.7.4.2. The method of support for the masonry veneer on wood construction shall be constructed in accordance with Figure R703.7.2.2.

The maximum slope of the roof construction without stops shall be 7:12. Roof construction with slopes greater than 7:12 but not more than 12:12 shall have stops of a minimum 3 inches \times 3 inches \times $\frac{1}{4}$ inch (76 mm \times 76 mm \times 6 mm) steel plate welded to the angle at 24 inches (610 mm) on center along the angle or as approved by the code enforcement official.

R703.7.3 Lintels. Masonry veneer shall not support any vertical load other than the dead load of the veneer above. Veneer above openings shall be supported on lintels of non-combustible materials and the allowable span shall not exceed the values set forth in Table R703.7.3. The lintels shall have a length of bearing of not less than 4 inches (102 mm).

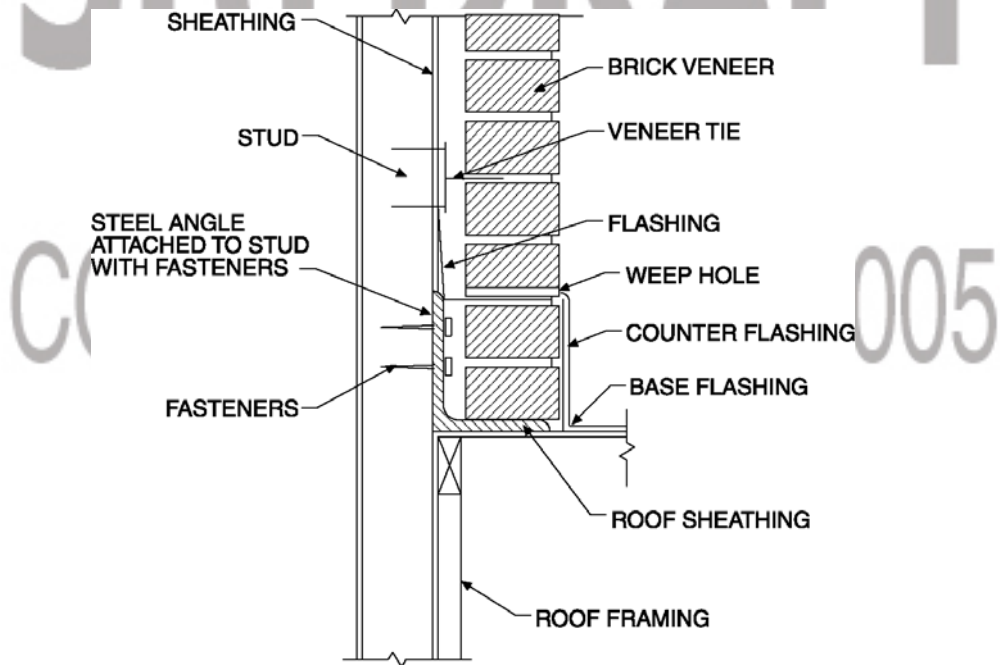

SUPPORT BY STEEL ANGLE

FIGURE R703.7.2.1
EXTERIOR MASONRY VENEER SUPPORT BY STEEL ANGLES

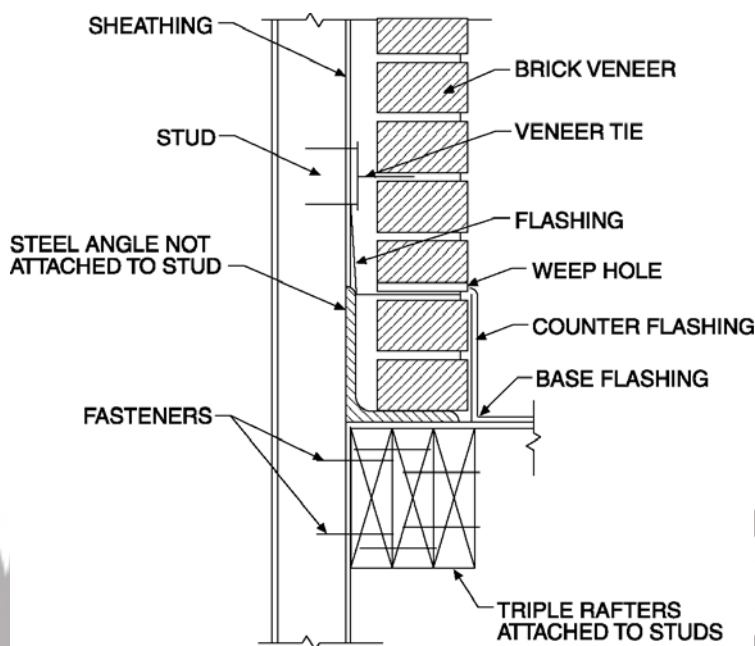

SUPPORT BY ROOF MEMBERS

FIGURE R703.7.2.2
EXTERIOR MASONRY VENEER SUPPORT BY ROOF MEMBERS

TABLE R703.7.3
ALLOWABLE SPANS FOR LINTELS SUPPORTING MASONRY VENEER^{a,b,c}

SIZE OF STEEL ANGLE ^{a,c} (inches)	NO STORY ABOVE	ONE STORY ABOVE	TWO STORIES ABOVE	NO. OF 1/2" OR EQUIVALENT REINFORCING BARS ^c
3 × 3 × 1/4	6'-0"	4'-6"	3'-0"	1
4 × 3 × 1/4	8'-0"	6'-0"	4'-6"	1
5 × 3 1/2 × 5/16	10'-0"	8'-0"	6'-0"	2
6 × 3 1/2 × 5/16	14'-0"	9'-6"	7'-0"	2
2-6 × 3 1/2 × 5/16	20'-0"	12'-0"	9'-6"	4

For SI: 1 inch = 25.4 mm, 1 foot = 304.8 mm.

- a. Long leg of the angle shall be placed in a vertical position.
 b. Depth of reinforced lintels shall not be less than 8 inches and all cells of hollow masonry lintels shall be grouted solid. Reinforcing bars shall extend not less than 8 inches into the support.
 c. Steel members indicated are adequate typical examples; other steel members meeting structural design requirements may be used.

R703.7.4 Anchorage. Masonry veneer shall be anchored to the supporting wall with corrosion-resistant metal ties. Where veneer is anchored to wood backings through the use of corrugated sheet metal ties, the distance separating the veneer from the sheathing material shall be a maximum of 1 inch (25.4 mm). Where the veneer is anchored to wood backings through the use of metal strand wire ties, the distance separating the veneer from the sheathing material shall be a maximum of 4 1/2 inches (114 mm). Where the veneer is anchored to cold-formed steel backings, adjustable metal strand wire ties shall be used. Where veneer is anchored to cold-formed steel backings, the distance separating the veneer from the sheathing material shall be a maximum of 4.5 inches (114 mm).

R703.7.4.1 Size and spacing. Veneer ties, if strand wire, shall not be less in thickness than No. 9 U.S. gage wire and shall have a hood embedded in the mortar joint, or if sheet metal, shall be not less than No. 22 U.S. gage by 7/8 inch (22.3 mm) corrugated. Each tie shall be spaced not more than 24 inches (610 mm) on center horizontally and vertically and shall support not more than 2.67 square feet (0.248 m²) of wall area.

Exception: In Seismic Design Category D₁ or D₂ and townhouses in Seismic Design Category C and in wind areas of more than 30 pounds per square foot pressure (1.44 kN/m²), each tie shall support not more than 2 square feet (0.186 m²) of wall area.

WALL COVERING

R703.7.4.1.1 Veneer ties around wall openings. Veneer ties around wall openings. Additional metal ties shall be provided around all wall openings greater than 16 inches (406 mm) in either dimension. Metal ties around the perimeter of openings shall be spaced not more than 3 feet (9144 mm) on center and placed within 12 inches (305 mm) of the wall opening.

R703.7.4.2 Air space. The veneer shall be separated from the sheathing by an air space of a minimum of 1 inch (25.4 mm) but not more than 4.5 inches (114 mm). The weather-resistant membrane or asphalt-saturated felt required by Section R703.2 is not required over water-repellent sheathing materials.

R703.7.4.3 Mortar or grout fill. As an alternate to the air space required by Section R703.7.4.2, mortar or grout shall be permitted to fill the air space. When the 1-inch (25.4 mm) space is filled with mortar, a weather-resistant membrane or building paper is required over studs or sheathing. When filling the air space, it is permitted to replace the sheathing and weather-resistant membrane or asphalt-saturated felt paper with a wire mesh and approved paper or an approved paper-backed reinforcement attached directly to the studs.

R703.7.5 Flashing. Flashing shall be located beneath the first course of masonry above finished ground level above the foundation wall or slab and at other points of support, including structural floors, shelf angles and lintels when masonry veneers are designed in accordance with Section R703.7. See Section R703.8 for additional requirements.

R703.7.6 Weepholes. Weepholes shall be provided in the outside wythe of masonry walls at a maximum spacing of 33 inches (838 mm) on center. Weepholes shall not be less than $\frac{3}{16}$ inch (4.8 mm) in diameter. Weepholes shall be located immediately above the flashing.

R703.8 Flashing. Approved corrosion-resistive flashing shall be provided in the exterior wall envelope in such a manner as to prevent entry of water into the wall cavity or penetration of water to the building structural framing components. The flashing shall extend to the surface of the exterior wall finish and shall be installed to prevent water from reentering the exterior wall envelope. Approved corrosion-resistant flashings shall be installed at all of the following locations:

1. At top of all exterior window and door openings in such a manner as to be leakproof, except that self-flashing windows having a continuous lap of not less than $1\frac{1}{8}$ inches (28 mm) over the sheathing material around the perimeter of the opening, including corners, do not require additional flashing and jamb flashing may also be omitted.
2. At the intersection of chimneys or other masonry construction with frame or stucco walls, with projecting lips on both sides under stucco copings.
3. Under and at the ends of masonry, wood or metal copings and sills.
4. Continuously above all projecting wood trim.
5. Where exterior porches, decks or stairs attach to a wall or floor assembly of wood-frame construction.
6. At wall and roof intersections.

7. At built-in gutters.

R703.9 Exterior insulation finish systems, general. All Exterior Insulation Finish Systems (EIFS) shall be installed in accordance with the manufacturer's installation instructions and the requirements of this section. Decorative trim shall not be face nailed through the EIFS. The EIFS shall terminate not less than 6 inches (152 mm) above the finished ground level.

R703.9.1 Weather-resistive barrier. All EIFS shall have a weather-resistive barrier applied between the underlying water-sensitive building components and the exterior insulation, and a means of draining water to the exterior of the veneer. A weather-resistive barrier shall be compliant with ASTM D 226 Type I asphalt saturated felt or equivalent, shall be applied horizontally with the upper layer lapped over the lower layer not less than 2 inches (51 mm), and shall have all vertical joints lapped not less than 6 inches (152 mm).

R703.9.2 Flashing, general. Flashing of EIFS shall be provided in accordance with the requirements of Section R703.8.

R703.10 Fiber cement siding.

R703.10.1 Panel siding. Panels shall be installed with the long dimension parallel to framing. Vertical joints shall occur over framing members and shall be sealed with caulking or covered with battens. Horizontal joints shall be flashed with Z-flashing and blocked with solid wood framing.

R703.10.2 Horizontal lap siding. Lap siding shall be lapped a minimum of $1\frac{1}{4}$ inches (32 mm) and shall have the ends sealed with caulking, covered with an H-section joint cover, or located over a strip of flashing. Lap siding courses may be installed with the fastener heads exposed or concealed, according to approved manufacturers' installation instructions.