

APPENDIX R

ACOUSTICAL TILE AND LAY-IN PANEL CEILING SUSPENSION SYSTEMS

SECTION BC R101 GENERAL

R101.1 General. Where required by Section 803.9 of this code, the provisions of ASTM C 635 and ASTM C 636, as modified by this appendix, shall govern the design and installation of ceiling suspension systems used to support acoustical tiles, or acoustical lay-in panels weighing less than 4 pounds per square foot (191.5 Pa), not contributing to the fire-resistance rating of a floor or roof assembly and not used for meeting the noise control requirements of the building code. Refer to the rules of the department for any subsequent additions, modifications or deletions that may have been made to this standard in accordance with Section 28-103.19 of the *Administrative Code*.

SECTION BC R102 MODIFICATIONS TO ASTM C 635 – STANDARD SPECIFICATION FOR THE MANUFACTURE, PERFORMANCE, AND TESTING OF METAL SUSPENSION SYSTEMS FOR ACOUSTICAL TILE AND LAY-IN PANEL CEILINGS

R102.1 ASTM C 635, Figure 1. Delete Figure 1 and replace as follows:

R102.2 ASTM C 635, Section 3.1. Modify section 3.1 as follows:

3.1.1.4 carrying channel – The term “carrying channel” shall mean the three sided or “U” shaped-metal sections that support the entire structural grid network (Figure 1A, 1B, and 1C). The carrying channels are suspended by hangers from the existing structure and main runners are then attached to the channels.

3.1.1.6 cross runner – The term “cross runner” shall mean the secondary or cross beams of a mechanical ceiling suspension (Figure 1A). The cross runners normally support only the acoustical tile. In some forms of suspension systems, the cross runners also provide support for other cross runners.

3.1.1.7 hanger – The term “hanger” shall mean the member employed to suspend the acoustical ceiling from the existing structure (wood joists, steel bar joists, steel beams, concrete slabs, etc.) (Figure 1A, 1B, and 1C).

3.1.1.10 main runner – The term “main runner” shall mean the primary or main beams of the type of ceiling suspension system in Figure 1A and Figure 1B. The main runners provide direct support for cross runners, and they may support lighting fixtures and air diffusers. In addition, the acoustical tile may also be directly supported by the main runners. The main runners are installed perpendicular to the carrying channels and are

supported by specially designed sheet metal or wire clips attached to the carrying channels (Figure 1A, 1B).

R102.3 ASTM C 635, Section 4.5. Add section 4.5 as follows:

4.5 Splines shall not be considered as providing nor shall be used for providing structural support for the ceiling material.

SECTION BC R103 MODIFICATIONS TO ASTM C 636 – STANDARD PRACTICE FOR INSTALLATION OF METAL CEILING SUSPENSION SYSTEMS FOR ACOUSTICAL TILE AND LAY-IN PANELS

R103.1 ASTM C 636, Section 2.1.3. Delete Section 2.1.3 and replace as follows:

2.1.3 Hangers shall be spaced a maximum of 4' 6" (1372 mm) on center. Each hanger shall be capable of supporting the suspended load in accordance with the provisions of this code. If local situations require greater center distances between hangers, the load-carrying capacity of the ceiling suspension system shall be reduced commensurate with the actual center-to-center hanger distances used.

R103.2 ASTM C 636, Section 2.1.4. Delete Section 2.1.4 and replace as follows:

2.1.4 Hangers shall be designed to support the suspended loads and shall be a minimum 1/4" (6.4 mm) diameter galvanized steel rods or 1' x 1/8" thick (25 mm x 3.2 mm) flat steel bars. The use of steel wire as a hanger shall not be permitted.

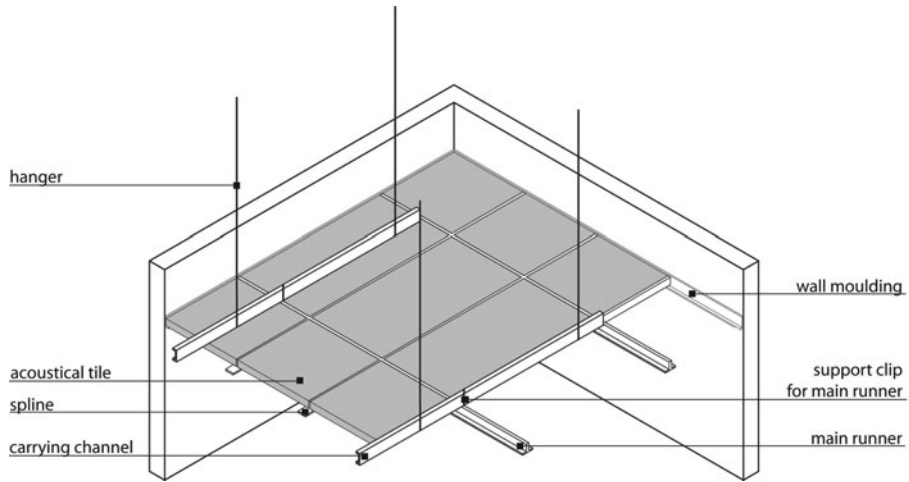
R103.3 ASTM C 636, Figure 1. Delete Figure 1 and replace as follows:

R103.4 ASTM C 636, Section 2.1.5. Delete Section 2.1.5 and replace as follows:

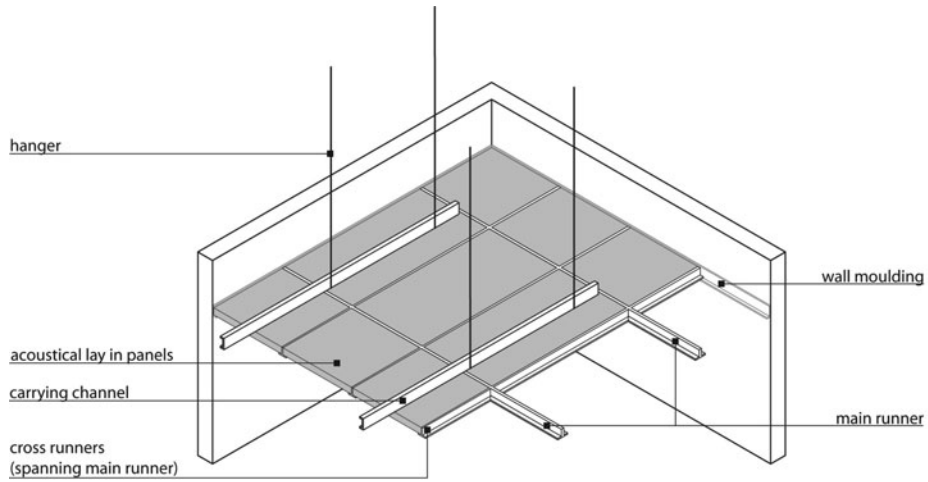
2.1.5 Each connection of a hanger to a structural member of the building shall be in accordance with Sections 2.1.5.1 or 2.1.5.2 as applicable.

2.1.5.1 Construction types I and II. In buildings of Types I and II construction, hangers shall be attached to the structure of the building in accordance with the applicable structural systems indicated in Figures 1A and 1B.

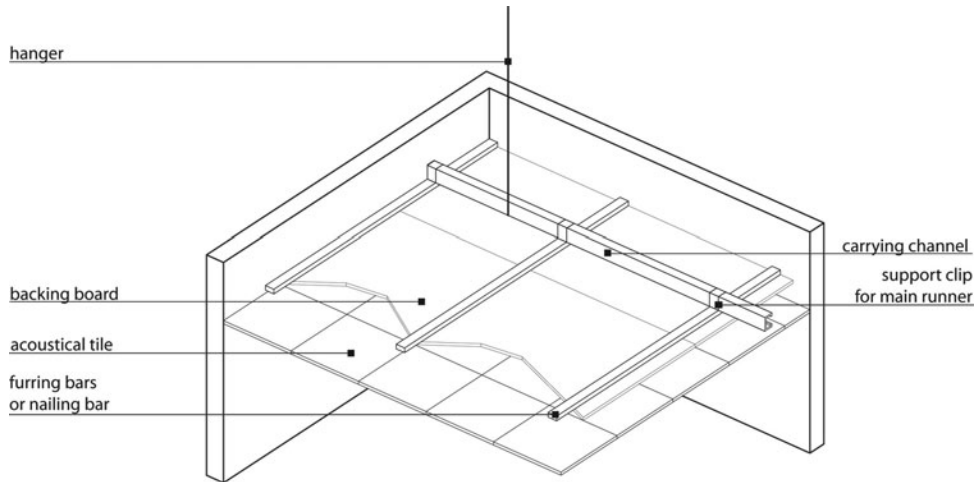
2.1.5.2 Construction types III, IV, and V. Every other hanger supported from wood structural members of the building shall be attached by two 1/4" (6.4 mm) diameter through bolts or clinched nails. However, every other hanger shall be permitted to be attached by two 1/4" (6.4 mm) diameter barbed anchor nails 2 1/4" (57 mm) long with oval heads. All bolts and nails shall be inserted at least 2 inches (51 mm) above the bottom of the wood members.



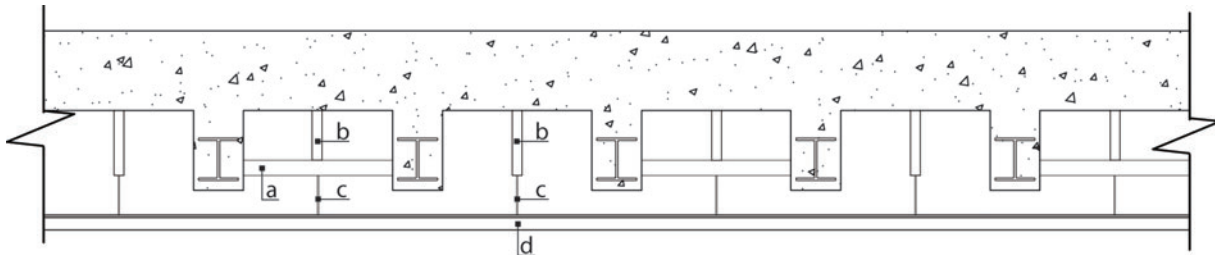
**FIGURE 1A
INDIRECT HUNG SUSPENSION SYSTEM**



**FIGURE 1B
INDIRECT HUNG SUSPENSION SYSTEM**

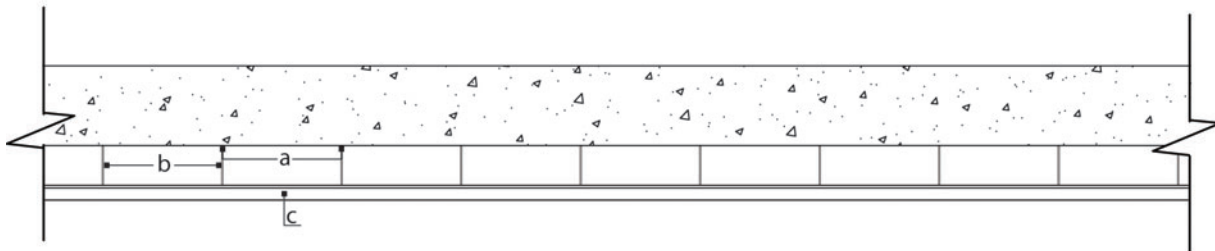


**FIGURE 1C
FURRING BAR SUSPENSION SYSTEM**



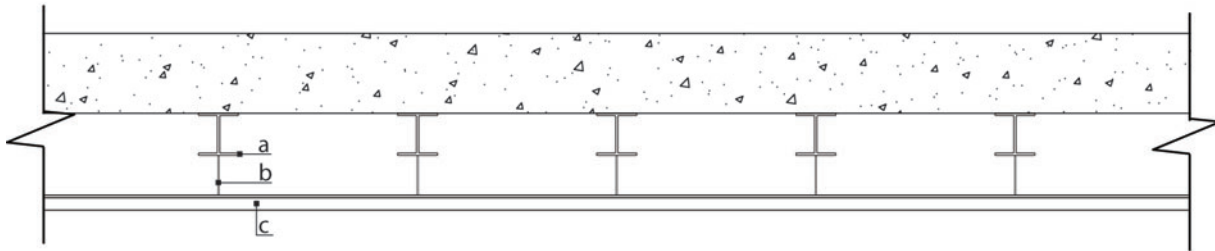
'cinder concrete arch'

- (a) 1-1/2" C bridging 85# hot rolled or 1-1/2" .803# cold formed furring channels not to exceed 4'-6" o.c.
- (b) hook over reinforcing 1" x 15" flat iron bolted to 'a' or punched to receive rod hanger.
- (c) 1/4" ϕ or 1" x 1/8" hanger not to exceed 4'-6" o.c.
- (d) 1-1/2" C cold rolled .475# carrying C not to exceed 4'-6" o.c.



'stone concrete arch'

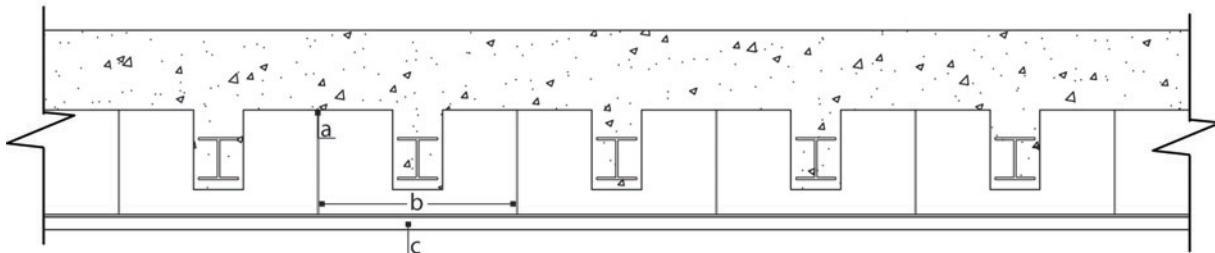
- (a) expansion shields or other approved fastening not to exceed 4'-6" o.c.
- (b) 1/4" ϕ or 1" x 1/8" hanger not to exceed 4'-6" o.c.
- (c) 1-1/2" C cold rolled .475# carrying C not to exceed 4'-6" o.c.



'exposed steel construction'

- (a) beam clamp or approved fastening device not to exceed 4'-6" o.c.
- (b) 1/4" ϕ or 1" x 1/8" hanger not to exceed 4'-6" o.c.
- (c) 1-1/2" C cold rolled .475# carrying C not to exceed 4'-6" o.c.

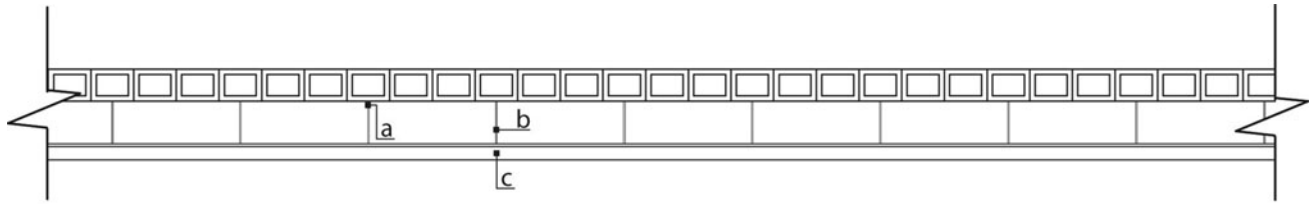
note
 construction similar to:
 (1) open steel joist
 (2) concrete plank
 (3) bulb tee



'new concrete arch'

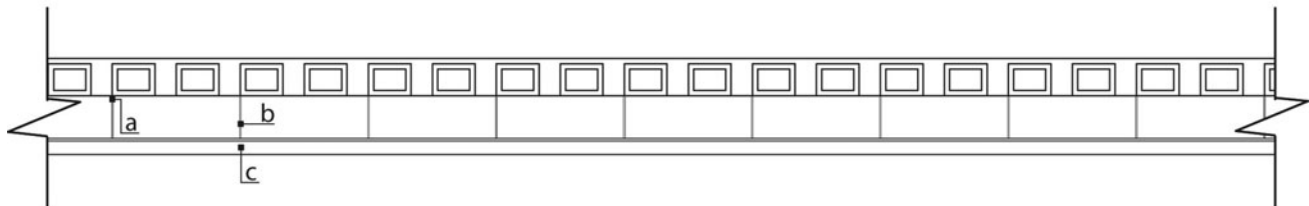
- (a) insert or approved fastening cast in slab not to exceed 4'-6" o.c.
- (b) 1/4" ϕ or 1" x 1/8" hanger not to exceed 4'-6" o.c.
- (c) 1-1/2" C cold rolled .475# carrying C not to exceed 4'-6" o.c.

**FIGURE 1A
 HANGER CONNECTION DETAILS FOR CONSTRUCTION GROUPS I AND II**



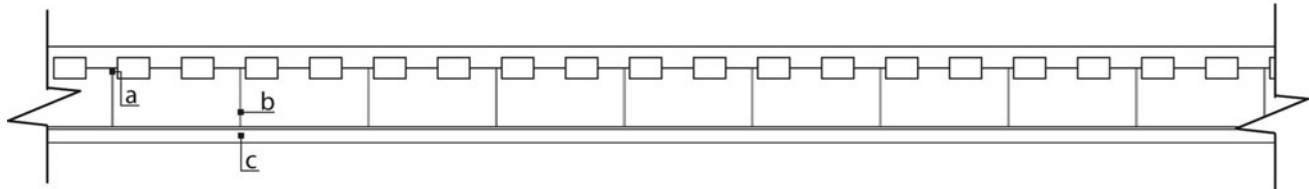
'terra cotta arch'

- (a) terra cotta insert 4'-0" x 3'-0" o.c.
- (b) 1/4" ϕ or 1" x 1/8" hangers 4'-0" x 3'-0" o.c.
- (c) 1-1/2" C cold rolled .475# carrying C not to exceed 4'-0" o.c.



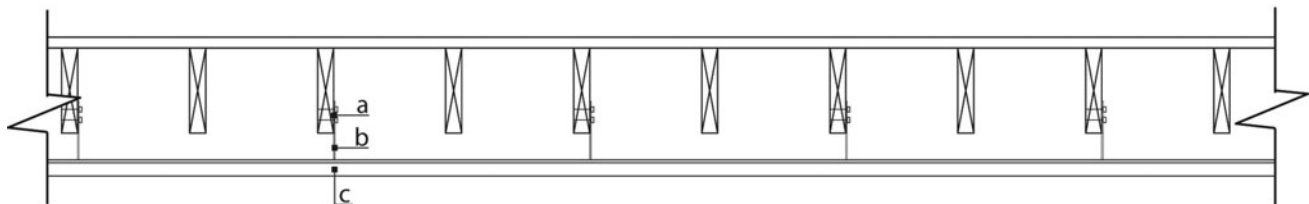
'republic arch'

- (a) expansion shields or other approved fastening not to exceed 4'-6" o.c.
- (b) 1/4" ϕ or 1" x 1/8" hanger not to exceed 4'-6" o.c.
- (c) 1-1/2" C cold rolled .475# carrying C not to exceed 4'-6" o.c.



'metal deck'

- (a) slot tab or other approved fastening not to exceed 4'-6" o.c.
- (b) 1/4" ϕ or 1" x 1/8" hanger not to exceed 4'-6" o.c.
- (c) 1-1/2" C cold rolled .475# carrying C not to exceed 4'-6" o.c.



'wood joist construction'

- (a) 1/8" strap secured to wood joist with two (2) 2" anchor nails not to exceed 4'-6" o.c.
- (b) 1/4" ϕ or 1" x 1/8" hanger not to exceed 4'-6" o.c.
- (c) 1-1/2" C cold rolled .475# carrying C not to exceed 4'-6" o.c.

**FIGURE 1B
HANGER CONNECTION DETAILS FOR CONSTRUCTION GROUPS I AND II**

R103.5 ASTM C 636, Section 2.1.6. Delete Section 2.1.6 and replace as follows:

2.1.6 Existing hangers shall not be used unless they comply, or are made to comply, with all of the provisions of this code relating to hangers.

R103.6 ASTM C 636, Section 2.1.7. Delete Section 2.1.7 and replace as follows:

2.1.7 Carrying channels shall be attached to hangers in a manner that will prevent any vertical movement or rotation. If hangers are secured to special attachment devices that support the carrying channels, such devices shall have certified load test data from an approved testing agency and shall be capable of carrying four times the design load.

R103.7 ASTM C 636, Section 2.2.3. Delete Section 2.2.3 and replace as follows:

2.2.3 Local kinks or bends shall not be made in hangers as a means of leveling the carrying channels.

R103.8 ASTM C 636, Section 2.2.4. Delete Section 2.2.4 and replace as follows:

2.2.4 Carrying channels shall be designed to support the suspended loads, and shall be a minimum 1½" deep (38 mm) cold-rolled steel channel weighing 0.457 pounds per linear foot (0.707 kg/m) and shall be given an electro-galvanized, hot-dipped galvanized cadmium coating, or zinc coating.

R103.9 ASTM C 636, Section 2.3.1. Delete Section 2.3.1 and replace as follows:

2.3.1 Main runners shall be installed such that they are level within ⅛" vertical in 12 feet horizontal (1-percent slope) when the main runner is in firm contact with the carrying channel.

R103.10 ASTM C 636, Section 2.3.2. Delete Section 2.3.2 and replace as follows:

2.3.2 Main runners shall be supported from the carrying channels. Direct hung suspension systems where the main runners are supported directly to the existing structure shall not be permitted indirect hung or furring bar suspension systems designed and installed in accordance with this code and utilizing carrying channels shall be permitted.

R103.11 ASTM C 636, Section 2.3.3. Delete Section 2.3.3 and replace as follows:

2.3.3 Main runners shall be attached to the carrying channels in a manner that will prevent any vertical movement or rotation.

R103.12 ASTM C 636, Section 2.3.4. Delete Section 2.3.4 and Figure 2 and replace as follows:

2.3.4 If the main runners are supported from the carrying channels by special devices, such devices shall be capable of carrying four times the design load. The devices shall be load tested by an approved testing agency that shall certify the devices are in compliance with this code. Such certifications shall be made available to the department and the applicant of record upon request.

R103.13 ASTM C 636, Section 2.7.2. Modify Section 2.7.2 to read as follows:

2.7.2 Fixtures shall not be supported from main runners if the weight of the fixture causes the total dead load to exceed the deflection capability of the ceiling suspension system. Fixtures exceeding 80 lbs (36 kg) in weight shall be supported independent of the ceiling suspension system. Fixtures weighing 80 lbs (36 kg) or less may be supported from the carrying channels. Fixtures weighing 50 lbs (23 kg) or less may be supported from the main runners. Cross runners shall not be used to support fixtures.

R103.14 ASTM C 636, Section 2.7.5. Add Section 2.7.5 to read as follows:

2.7.5 The construction documents shall show the necessary details of the acoustical ceiling to identify the number, size, spacing, location, weights, and types of fixtures and means employed to comply with these requirements.

