

# Part VI — Fuel Gas

## CHAPTER 24 FUEL GAS

### SECTION G2401 GENERAL

**G2401.1 Application.** This chapter covers those fuel- gas piping systems, fuel-gas utilization equipment and related accessories, venting systems and combustion air configurations most commonly encountered in the construction of one- and two-family dwellings and structures regulated by this code.

Coverage of piping systems shall extend from the point of delivery to the outlet of the equipment shutoff valves (see “Point of delivery”). Piping systems requirements shall include design, materials, components, fabrication, assembly, installation, testing, and inspection. Requirements for gas utilization equipment and related accessories shall include installation, combustion air and venting and connections to piping systems.

The omission from this chapter of any material or method of installation shall not be construed as prohibiting the use of such material or method of installation. Fuel-gas piping systems, fuel-gas utilization equipment and related accessories, venting systems and combustion air configurations not specifically covered in these chapters shall comply with the applicable provisions of the *Oregon Mechanical Specialty Code*.

Gaseous hydrogen systems shall be regulated by Appendix C of the *Oregon Mechanical Specialty Code*.

This chapter shall not apply to the following:

1. Liquefied natural gas (LNG) installations.
2. Temporary fuel-gas piping for buildings under construction or renovation that is not to become part of the permanent piping system.
3. Except as provided in Section G2412.1.1, gas piping, meters, gas pressure regulators, and other appurtenances used by the serving gas supplier in the distribution of gas, other than undiluted LP-gas.
4. Portable fuel-gas equipment of all types that is not connected to a fixed fuel piping system.
5. Portable fuel cell appliances that are neither connected to a fixed piping system nor interconnected to a power grid.
6. Installation of hydrogen gas, LP-gas and compressed natural gas (CNG) systems on vehicles.

### SECTION G2402 AUTHORITY TO RENDER GAS SERVICE

**G2402.1 Turn on authority.** A serving gas supplier, or person furnishing gas shall not turn on, or cause to be turned on, fuel gas or gas meters, until approval of rough piping inspection, in compliance with Section G2417.1.1.1.

**G2402.2 Temporary gas service.** Temporary fuel gas service shall be permitted upon approval of authority having jurisdiction.

### SECTION G2403 GENERAL DEFINITIONS

**G2403.1 Scope.** Unless otherwise expressly stated, the following words and terms shall, for the purposes of this code and standard, have the meanings indicated in this chapter.

**G2403.2 Interchangeability.** Words used in the present tense include the future; words in the masculine gender include the feminine and neuter; the singular number includes the plural and the plural, the singular.

**G2403.3 Terms defined in other codes.** Where terms are not defined in this code and are defined in the *Electrical Code*, *Building Code*, *Fire Code*, *Mechanical Code* or *Plumbing Code*, such terms shall have meanings ascribed to them as in those codes.

**ACCESS (TO).** That which enables a device, appliance or equipment to be reached by ready access or by a means that first requires the removal or movement of a panel, door or similar obstruction (see also “Ready access”).

**AIR CONDITIONING, GAS FIRED.** A gas-burning, automatically operated appliance for supplying cooled and/or dehumidified air or chilled liquid.

**AIR-HANDLING UNIT.** A blower or fan used for the purpose of distributing supply air to a room, space or area.

**ANODELESS RISER.** A transition assembly in which plastic piping is installed and terminated above ground outside of a building.

**APPLIANCE (EQUIPMENT).** Any apparatus or equipment that utilizes gas as a fuel or raw material to produce light, heat, power, refrigeration or air conditioning.

**APPLIANCE, FAN-ASSISTED COMBUSTION.** An appliance equipped with an integral mechanical means to either draw or force products of combustion through the combustion chamber or heat exchanger.

**APPLIANCE, AUTOMATICALLY CONTROLLED.** Appliances equipped with an automatic burner ignition and safety shut-off device and other automatic devices, which accomplish complete turn-on and shut-off of the gas to the main burner or burners, and graduate the gas supply to the burner or burners, but do not affect complete shut-off of the gas.

**APPLIANCE, UNVENTED.** An appliance designed or installed in such a manner that the products of combustion are not

## FUEL GAS

conveyed by a vent or chimney directly to the outside atmosphere.

**APPLIANCE, VENTED.** An appliance designed and installed in such a manner that all of the products of combustion are conveyed directly from the appliance to the outside atmosphere through an approved chimney or vent system.

**ATMOSPHERIC PRESSURE.** The pressure of the weight of air and water vapor on the surface of the earth, approximately 14.7 pounds per square inch (psia) (101 kPa absolute) at sea level.

**AUTOMATIC IGNITION.** Ignition of gas at the burner(s) when the gas controlling device is turned on, including reignition if the flames on the burner(s) have been extinguished by means other than by the closing of the gas controlling device.

**BAROMETRIC DRAFT REGULATOR.** A balanced damper device attached to a chimney, vent connector, breeching or flue gas manifold to protect combustion equipment by controlling chimney draft. A double-acting barometric draft regulator is one whose balancing damper is free to move in either direction to protect combustion equipment from both excessive draft and backdraft.

**BTU.** Abbreviation for British thermal unit, which is the quantity of heat required to raise the temperature of 1 pound (454 g) of water 1°F (0.56°C) (1 Btu = 1055 J).

**BURNER.** A device for the final conveyance of the gas, or a mixture of gas and air, to the combustion zone.

**Induced-draft.** A burner that depends on draft induced by a fan that is an integral part of the appliance and is located downstream from the burner.

**Power.** A burner in which gas, air or both are supplied at pressures exceeding, for gas, the line pressure, and for air, atmospheric pressure, with this added pressure being applied at the burner.

**CHIMNEY.** A primarily vertical structure containing one or more flues, for the purpose of carrying gaseous products of combustion and air from an appliance to the outside atmosphere.

**Factory-built chimney.** A listed and labeled chimney composed of factory-made components, assembled in the field in accordance with manufacturer's instructions and the conditions of the listing.

**Masonry chimney.** A field-constructed chimney composed of solid masonry units, bricks, stones or concrete.

**CLEARANCE.** The minimum distance through air measured between the heat-producing surface of the mechanical appliance, device or equipment and the surface of the combustible material or assembly.

**COMBUSTION.** In the context of this code, refers to the rapid oxidation of fuel accompanied by the production of heat or heat and light.

**COMBUSTION AIR.** Air necessary for complete combustion of a fuel, including theoretical air and excess air.

**COMBUSTION CHAMBER.** The portion of an appliance within which combustion occurs.

**COMBUSTION PRODUCTS.** Constituents resulting from the combustion of a fuel with the oxygen of the air, including the inert gases, but excluding excess air.

**CONCEALED LOCATION.** A location that cannot be accessed without damaging permanent parts of the building structure or finish surface. Spaces above, below or behind readily removable panels or doors shall not be considered as concealed.

**CONCEALED PIPING.** Piping that is located in a concealed location (see "Concealed location").

**CONDENSATE.** The liquid that condenses from a gas (including flue gas) caused by a reduction in temperature or increase in pressure.

**CONNECTOR.** The pipe that connects an approved appliance to a chimney, flue or vent.

**CONTROL.** A manual or automatic device designed to regulate the gas, air, water or electrical supply to, or operation of, a mechanical system.

**CONVERSION BURNER.** A unit consisting of a burner and its controls for installation in an appliance originally utilizing another fuel.

**CUBIC FOOT.** The amount of gas that occupies 1 cubic foot (0.02832 m<sup>3</sup>) when at a temperature of 60°F (16°C), saturated with water vapor and under a pressure equivalent to that of 30 inches of mercury (101 kPa).

**DAMPER.** A manually or automatically controlled device to regulate draft or the rate of flow of air or combustion gases.

**DECORATIVE GAS APPLIANCE, VENTED.** A vented appliance wherein the primary function lies in the aesthetic effect of the flames.

**DECORATIVE GAS APPLIANCES FOR INSTALLATION IN VENTED FIREPLACES.** A vented appliance designed for installation within the fire chamber of a vented fireplace, wherein the primary function lies in the aesthetic effect of the flames.

**DEMAND.** The maximum amount of gas input required per unit of time, usually expressed in cubic feet per hour, or Btu/h (1 Btu/h = 0.2931 W).

**DESIGN FLOOD ELEVATION.** The elevation of the "design flood," including wave height, relative to the datum specified on the community's legally designated flood hazard map.

**DILUTION AIR.** Air that is introduced into a draft hood and is mixed with the flue gases.

**DIRECT-VENT APPLIANCES.** Appliances that are constructed and installed so that all air for combustion is derived directly from the outside atmosphere and all flue gases are discharged directly to the outside atmosphere.

**DRAFT.** The pressure difference existing between the equipment or any component part and the atmosphere, that causes a continuous flow of air and products of combustion through the gas passages of the appliance to the atmosphere.

**Mechanical or induced draft.** The pressure difference created by the action of a fan, blower or ejector that is located between the appliance and the chimney or vent termination.

**Natural draft.** The pressure difference created by a vent or chimney because of its height, and the temperature difference between the flue gases and the atmosphere.

**DRAFT HOOD.** A nonadjustable device built into an appliance, or made as part of the vent connector from an appliance, that is designed to (1) provide for ready escape of the flue gases from the appliance in the event of no draft, backdraft, or stoppage beyond the draft hood, (2) prevent a backdraft from entering the appliance, and (3) neutralize the effect of stack action of the chimney or gas vent upon operation of the appliance.

**DRAFT REGULATOR.** A device that functions to maintain a desired draft in the appliance by automatically reducing the draft to the desired value.

**DRIP.** The container placed at a low point in a system of piping to collect condensate and from which the condensate is removable.

**DUCT FURNACE.** A warm-air furnace normally installed in an air-distribution duct to supply warm air for heating. This definition shall apply only to a warm-air heating appliance that depends for air circulation on a blower not furnished as part of the furnace.

**EQUIPMENT.** See "Appliance."

> **FLAME SAFEGUARD.** A device that will automatically shut off the fuel supply to a main burner or group of burners when the means of ignition of such burners becomes inoperative, and when flame failure occurs on the burner or group of burners.

**FLOOD HAZARD AREA.** The greater of the following two areas:

1. The area within a floodplain subject to a 1 percent or greater chance of flooding in any given year.
2. This area designated as a flood hazard area on a community's flood hazard map, or otherwise legally designated.

**FLOOR FURNACE.** A completely self-contained furnace suspended from the floor of the space being heated, taking air for combustion from outside such space and with means for observing flames and lighting the appliance from such space.

**FLUE, APPLIANCE.** The passage(s) within an appliance through which combustion products pass from the combustion chamber of the appliance to the draft hood inlet opening on an appliance equipped with a draft hood or to the outlet of the appliance on an appliance not equipped with a draft hood.

**FLUE COLLAR.** That portion of an appliance designed for the attachment of a draft hood, vent connector or venting system.

**FLUE GASES.** Products of combustion plus excess air in appliance flues or heat exchangers.

**FLUE LINER (LINING).** A system or material used to form the inside surface of a flue in a chimney or vent, for the purpose of protecting the surrounding structure from the effects of combustion products and for conveying combustion products without leakage to the atmosphere.

**FUEL GAS.** Fuel gases include: a natural gas, manufactured gas, liquefied petroleum gas, hydrogen gas and mixtures of these gases.

**FUEL GAS UTILIZATION EQUIPMENT.** See "Appliance."

**FURNACE.** A completely self-contained heating unit that is designed to supply heated air to spaces remote from or adjacent to the appliance location.

**FURNACE, CENTRAL FURNACE.** A self-contained appliance for heating air by transfer of heat of combustion through metal to the air, and designed to supply heated air through ducts to spaces remote from or adjacent to the appliance location.

**FURNACE PLENUM.** An air compartment or chamber to which one or more ducts are connected and which forms part of an air distribution system.

**GAS CONVENIENCE OUTLET.** A permanently mounted, manually operated device that provides the means for connecting an appliance to, and disconnecting an appliance from, the gas supply piping. The device includes an integral, manually operated valve with a nondisplaceable valve member and is designed so that disconnection of an appliance only occurs when the manually operated valve is in the closed position.

**GAS PIPING.** An installation of pipe, valves or fittings installed on a premises or in a building and utilized to convey fuel gas.

**GAS UTILIZATION EQUIPMENT.** An appliance that utilizes gas as a fuel or raw material or both.

**HAZARDOUS LOCATION.** Any location considered to be a fire hazard for flammable vapors, dust, combustible fibers or other highly combustible substances. The location is not necessarily categorized in the *International Building Code* as a high-hazard use group classification.

**HOUSE PIPING.** See "Piping system."

**IGNITION PILOT.** A pilot that operates during the lighting cycle and discontinues during main burner operation.

**IGNITION SOURCE.** A flame spark or hot surface capable of igniting flammable vapors or fumes. Such sources include appliance burners, burner ignitors and electrical switching devices.

**INFRARED RADIANT HEATER.** A heater which directs a substantial amount of its energy output in the form of infrared radiant energy into the area to be heated. Such heaters are of either the vented or unvented type.

**JOINT, FLARED.** A metal-to-metal compression joint in which a conical spread is made on the end of a tube that is compressed by a flare nut against a mating flare.

**JOINT, MECHANICAL.** A general form of gas-tight joints obtained by the joining of metal parts through a positive-holding mechanical construction, such as flanged joint, threaded joint, flared joint or compression joint.

**JOINT, PLASTIC ADHESIVE.** A joint made in thermoset plastic piping by the use of an adhesive substance which forms a continuous bond between the mating surfaces without dissolving either one of them.

**LIQUEFIED PETROLEUM GAS or LPG (LP-GAS).** Liquefied petroleum gas composed predominately of propane, propylene, butanes or butylenes, or mixtures thereof that is gaseous under normal atmospheric conditions, but is capable of being liquefied under moderate pressure at normal temperatures.

## FUEL GAS

**LOG LIGHTER, GAS-FIRED.** A manually operated solid-fuel ignition appliance for installation in a vented solid-fuel-burning fireplace.

**MAIN BURNER.** A device or group of devices essentially forming an integral unit for the final conveyance of gas or a mixture of gas and air to the combustion zone, and on which combustion takes place to accomplish the function for which the appliance is designed.

**MECHANICAL EXHAUST SYSTEM.** Equipment installed in and made a part of the vent, which will provide a positive induced draft.

**METER.** The instrument installed to measure the volume of gas delivered through it.

**MODULATING.** Modulating or throttling is the action of a control from its maximum to minimum position in either predetermined steps or increments of movement as caused by its actuating medium.

**OFFSET (VENT).** A combination of approved bends that make two changes in direction bringing one section of the vent out of line, but into a line parallel with the other section.

**OUTLET.** A threaded connection or bolted flange in a pipe system to which a gas-burning appliance is attached.

**OXYGEN DEPLETION SAFETY SHUTOFF SYSTEM (ODS).** A system designed to act to shut off the gas supply to the main and pilot burners if the oxygen in the surrounding atmosphere is reduced below a predetermined level.

**PILOT.** A small flame that is utilized to ignite the gas at the main burner or burners.

**PIPING.** Where used in this code, "piping" refers to either pipe or tubing, or both.

**Pipe.** A rigid conduit of iron, steel, copper, brass or plastic.

**Tubing.** Semirigid conduit of copper, aluminum, plastic or steel.

**PIPING SYSTEM.** All fuel piping, valves, and fittings from the outlet of the point of delivery to the outlets of the equipment shutoff valves.

**PLASTIC, THERMOPLASTIC.** A plastic that is capable of being repeatedly softened by increase of temperature and hardened by decrease of temperature.

**POINT OF DELIVERY.** For natural gas systems, the point of delivery is the outlet of the service meter assembly, or the outlet of the service regulator or service shutoff valve where a meter is not provided. Where a valve is provided at the outlet of the service meter assembly, such valve shall be considered to be downstream of the point of delivery. For undiluted liquefied petroleum gas systems, the point of delivery shall be considered the outlet of the first-stage pressure regulator that provides utilization pressure, exclusive of line gas regulators, in the system.

**PRESSURE DROP.** The loss in pressure due to friction or obstruction in pipes, valves, fittings, regulators and burners.

**PRESSURE TEST.** An operation performed to verify the gas-tight integrity of gas piping following its installation or modification.

**READY ACCESS (TO).** That which enables a device, appliance or equipment to be directly reached, without requiring the removal or movement of any panel, door or similar obstruction. (See "Access.")

**REGULATOR.** A device for controlling and maintaining a uniform gas supply pressure, either pounds-to-inches water column (MP regulator) or inches-to-inches water column (appliance regulator).

**REGULATOR, GAS APPLIANCE.** A pressure regulator for controlling pressure to the manifold of gas equipment.

**REGULATOR, LINE GAS PRESSURE.** A device placed in a gas line between the service pressure regulator and the equipment for controlling, maintaining or reducing the pressure in that portion of the piping system downstream of the device.

**REGULATOR, PRESSURE.** A device placed in a gas line for reducing, controlling and maintaining the pressure in that portion of the piping system downstream of the device.

**REGULATOR, SERVICE PRESSURE.** A device installed by the serving gas supplier to reduce and limit the service line gas pressure to delivery pressure.

**RELIEF OPENING.** The opening provided in a draft hood to permit the ready escape to the atmosphere of the flue products from the draft hood in the event of no draft, backdraft or stoppage beyond the draft hood, and to permit air into the draft hood in the event of a strong chimney updraft.

**RISER, GAS.** A vertical pipe supplying fuel gas.

**ROOM HEATER, UNVENTED.** See "Unvented room heater."

**ROOM HEATER, VENTED.** A free-standing gas-fired heating unit used for direct heating of the space in and adjacent to that in which the unit is located. [See also "Vented room heater."]

**SAFETY SHUTOFF DEVICE.** See "Flame safeguard."

**SPECIFIC GRAVITY.** As applied to gas, specific gravity is the ratio of the weight of a given volume to that of the same volume of air, both measured under the same condition.

## THERMOSTAT

**Electric switch type.** A device that senses changes in temperature and controls electrically, by means of separate components, the flow of gas to the burner(s) to maintain selected temperatures.

**Integral gas valve type.** An automatic device, actuated by temperature changes, designed to control the gas supply to the burner(s) in order to maintain temperatures between predetermined limits, and in which the thermal actuating element is an integral part of the device.

1. Graduating thermostat. A thermostat in which the motion of the valve is approximately in direct proportion to the effective motion of the thermal element induced by temperature change.
2. Snap-acting thermostat. A thermostat in which the thermostatic valve travels instantly from the closed to the open position, and vice versa.

**TRANSITION FITTINGS, PLASTIC TO STEEL.** An adapter for joining plastic pipe to steel pipe. The purpose of this fitting is to provide a permanent, pressure-tight connection between two materials that cannot be joined directly one to another.

#### UNIT HEATER

**High-static pressure type.** A self-contained, automatically controlled, vented appliance having integral means for circulation of air against 0.2 inch (15 mm H<sub>2</sub>O) or greater static pressure. Such appliance is equipped with provisions for attaching an outlet air duct and, where the appliance is for indoor installation remote from the space to be heated, is also equipped with provisions for attaching an inlet air duct.

**Low-static pressure type.** A self-contained, automatically controlled, vented appliance, intended for installation in the space to be heated without the use of ducts, having integral means for circulation of air. Such units are allowed to be equipped with louvers or face extensions made in accordance with the manufacturer's specifications.

**UNVENTED ROOM HEATER.** An unvented heating appliance designed for stationary installation and utilized to provide comfort heating. Such appliances provide radiant heat or convection heat by gravity or fan circulation directly from the heater and do not utilize ducts.

**VALVE.** A device used in piping to control the gas supply to any section of a system of piping or to an appliance.

**Automatic.** An automatic or semiautomatic device consisting essentially of a valve and operator that control the gas supply to the burner(s) during operation of an appliance. The operator shall be actuated by application of gas pressure on a flexible diaphragm, by electrical means, by mechanical means or by other approved means.

**Automatic gas shutoff.** A valve used in conjunction with an automatic gas shutoff device to shut off the gas supply to a water heating system. It shall be constructed integrally with the gas shutoff device or shall be a separate assembly.

**Equipment shutoff.** A valve located in the piping system, used to isolate individual equipment for purposes such as service or replacement.

**Individual main burner.** A valve that controls the gas supply to an individual main burner.

**Main burner control.** A valve that controls the gas supply to the main burner manifold.

**Manual main gas-control.** A manually operated valve in the gas line for the purpose of completely turning on or shutting off the gas supply to the appliance, except to pilot or pilots that are provided with independent shutoff.

**Manual reset.** An automatic shutoff valve installed in the gas supply piping and set to shut off when unsafe conditions occur. The device remains closed until manually reopened.

**Service shutoff.** A valve, installed by the serving gas supplier between the service meter or source of supply and the customer piping system, to shut off the entire piping system.

**VENT.** A pipe or other conduit composed of factory-made components, containing a passageway for conveying combus-

tion products and air to the atmosphere, listed and labeled for use with a specific type or class of appliance.

**Special gas vent.** A vent listed and labeled for use with listed Category II, III and IV gas appliances.

**Type B vent.** A vent listed and labeled for use with appliances with draft hoods and other Category I appliances that are listed for use with Type B vents.

**Type BW vent.** A vent listed and labeled for use with wall furnaces.

**Type L vent.** A vent listed and labeled for use with appliances that are listed for use with Type L or Type B vents.

**VENT CONNECTOR.** (See "Connector.")

**VENTED GAS APPLIANCE CATEGORIES.** Appliances that are categorized for the purpose of vent selection are classified into the following four categories:

**Category I.** An appliance that operates with a nonpositive vent static pressure and with a vent gas temperature that avoids excessive condensate production in the vent.

**Category II.** An appliance that operates with a nonpositive vent static pressure and with a vent gas temperature that is capable of causing excessive condensate production in the vent.

**Category III.** An appliance that operates with a positive vent static pressure and with a vent gas temperature that avoids excessive condensate production in the vent.

**Category IV.** An appliance that operates with a positive vent static pressure and with a vent gas temperature that is capable of causing excessive condensate production in the vent.

**VENTED ROOM HEATER.** A vented self-contained, free-standing, nonrecessed appliance for furnishing warm air to the space in which it is installed, directly from the heater without duct connections.

**VENTED WALL FURNACE.** A self-contained vented appliance complete with grilles or equivalent, designed for incorporation in or permanent attachment to the structure of a building, mobile home or travel trailer, and furnishing heated air circulated by gravity or by a fan directly into the space to be heated through openings in the casing. This definition shall exclude floor furnaces, unit heaters and central furnaces as herein defined.

**VENTING SYSTEM.** A continuous open passageway from the flue collar or draft hood of an appliance to the outside atmosphere for the purpose of removing flue or vent gases. A venting system is usually composed of a vent or a chimney and vent connector, if used, assembled to form the open passageway.

**WALL HEATER, UNVENTED TYPE.** A room heater of the type designed for insertion in or attachment to a wall or partition. Such heater does not incorporate concealed venting arrangements in its construction and discharges all products of combustion through the front into the room being heated.

FUEL GAS

**SECTION G2404  
GENERAL**

**G2404.1 Scope.** This section shall govern the approval and installation of all equipment and appliances that comprise parts of the installations regulated by this code in accordance with Section G2401. Gas equipment listed to and installed in accordance with the standards specified in ANSI Z23.1, as listed in Chapter 43, shall be permitted.

**G2404.2 Other fuels.** The requirements for combustion and dilution air for gas-fired appliances shall be governed by Section G2407. The requirements for combustion and dilution air for appliances operating with fuels other than fuel gas shall be regulated by Chapters 12 through 23.

**G2404.3 Listed and labeled.** Appliances regulated by this code shall be listed and labeled unless otherwise approved in accordance with Section R104.11.

**G2404.4 Vibration isolation.** Shall be installed in accordance with Section M1601.2.2.

**G2404.5 Repair.** Defective material or parts shall be replaced or repaired in such a manner so as to preserve the original approval or listing.

**G2404.6 Flood hazard.** For structures located in flood hazard areas, as established by the local jurisdiction, the appliance, equipment and system installations regulated by this code shall be located at or above the design flood elevation and shall comply with the flood-resistant construction requirements of Section R323.

**Exception:** The appliance, equipment and system installations regulated by this code are permitted to be located below the design flood elevation provided that they are designed and installed to prevent water from entering or accumulating within the components and to resist hydrostatic and hydrodynamic loads and stresses, including the effects of buoyancy, during the occurrence of flooding to the design flood elevation and shall comply with the flood-resistant construction requirements of Section R323.

**G2404.7 Rodent proofing.** Buildings or structures and the walls enclosing habitable or occupiable rooms and spaces in which persons live, sleep or work, or in which feed, food or foodstuffs are stored, prepared, processed, served or sold, shall be constructed to protect against the entry of rodents.

**SECTION G2405  
STRUCTURAL SAFETY**

**G2405.1 Structural safety.** The building shall not be weakened by the installation of any gas piping. In the process of installing or repairing any gas piping, the finished floors, walls, ceilings, tile work or any other part of the building or premises which are required to be changed or replaced shall be left in a safe structural condition.

**G2405.2 Alterations to trusses.** Truss members and components shall not be cut, drilled, notched, spliced or otherwise altered in any way without the written concurrence and approval of a registered design professional. Alterations resulting in the addition of loads to any member (e.g., HVAC equipment, water

heaters) shall not be permitted without verification that the truss is capable of supporting such additional loading.

**SECTION G2406  
APPLIANCE LOCATION**

**G2406.1 General.** Appliances shall be located as required by this section, specific requirements elsewhere in this code and the conditions of the equipment and appliance listing.

**G2406.2 Prohibited locations.** Appliances shall not be located in, or obtain combustion air from, any of the following rooms or spaces:

1. Sleeping rooms.
2. Bathrooms.
3. Toilet rooms.
4. Storage closets.

**Exceptions:**

1. Direct-vent appliances that obtain all combustion air directly from the outdoors.
2. Vented room heaters, wall furnaces, vented decorative appliances and decorative appliances for installation in vented solid fuel-burning fireplaces, provided that the room meets the required volume criteria of Section G2407.5.
3. A single wall-mounted unvented room heater equipped with an oxygen depletion safety shutoff system and installed in a bathroom, provided that the input rating does not exceed 6,000 Btu/h (1.76kW) and the bathroom meets the required volume criteria of Section G2407.5.
4. A single wall-mounted unvented room heater equipped with an oxygen depletion safety shutoff system and installed in a bedroom, provided that the input rating does not exceed 10,000 Btu/h (2.93 kW) and the bedroom meets the required volume criteria of Section G2407.5.
5. Appliances installed in an enclosure in which all combustion air is taken from the outdoors, in accordance with Section G2407.6. Access to such enclosure shall be through a solid weather-stripped door, equipped with an approved self-closing device.

**G2406.3 Outdoor locations.** Equipment installed in outdoor locations shall be listed for outdoor installation.

**SECTION G2407  
COMBUSTION AND DILUTION AIR**

**G2407.1 General.** Air for combustion and dilution of flue gases for gas utilization equipment installed in buildings shall be provided by application of one of the methods prescribed in Sections G2407.5 through G2407.9. Where the requirements of Section G2407.5 are not met, outdoor air shall be introduced in accordance with one of the methods prescribed in Sections G2407.6 through G2407.9. Direct-vent appliances, gas appliances of other than natural draft design and vented gas appliances other than Category I shall be provided with combustion

> and dilution air in accordance with the equipment manufacturer's instructions.

**Exception:** Type 1 clothes dryers that are provided with makeup air in accordance with Section G2439.4.

**G2407.2 Appliance/equipment location.** Equipment shall be located so as not to interfere with proper circulation of combustion and dilution air.

**G2407.3 Draft hood/regulator location.** Where used, a draft hood or a barometric draft regulator shall be installed in the same room or enclosure as the equipment served so as to prevent any difference in pressure between the hood or regulator and the combustion air supply.

**G2407.4 Makeup air provisions.** Makeup air requirements for the operation of exhaust fans, kitchen ventilation systems, clothes dryers and fireplaces shall be considered in determining the adequacy of a space to provide combustion air requirements.

**G2407.4.1 Special conditions.** In buildings containing combustion appliances, equipment or fireplaces not equipped with forced or induced draft or separated from the habitable area, where an individual exhaust appliance exceeds 350 cfm (165.2L/s), make-up air of sufficient quantity to equal that being exhausted shall be supplied to the area being ventilated. In such cases, the minimum size make-up air duct shall be 6 inches (152 mm) in diameter or equivalent area.

**G2407.5 Indoor combustion air.** The required volume of indoor air shall be determined in accordance with Section G2407.5.1 or G2407.5.2, except that where the air infiltration rate is known to be less than 0.40 air changes per hour (ACH), Section G2407.5.2 shall be used. The total required volume shall be the sum of the required volume calculated for all appliances located within the space. Rooms communicating directly with the space in which the appliances are installed through openings not furnished with doors, and through combustion air openings sized and located in accordance with Section G2407.5.3, are considered to be part of the required volume.

**G2407.5.1 Standard method.** The minimum required volume shall be 50 cubic feet per 1,000 Btu/h (4.8 m<sup>3</sup>/kW).

**G2407.5.2 Known air-infiltration-rate method.** Where the air infiltration rate of a structure is known, the minimum required volume shall be determined as follows:

For appliances other than fan assisted, calculate volume using Equation 24-1.

$$\text{Required Volume}_{\text{other}} \geq \frac{21 \text{ ft}^3}{ACH} \left( \frac{I_{\text{other}}}{1,000 \text{ Btu/hr}} \right) \quad \text{(Equation 24-1)}$$

For fan-assisted appliances, calculate volume using Equation 24-2.

$$\text{Required Volume}_{\text{fan}} \geq \frac{15 \text{ ft}^3}{ACH} \left( \frac{I_{\text{fan}}}{1,000 \text{ Btu/hr}} \right) \quad \text{(Equation 24-2)}$$

where:

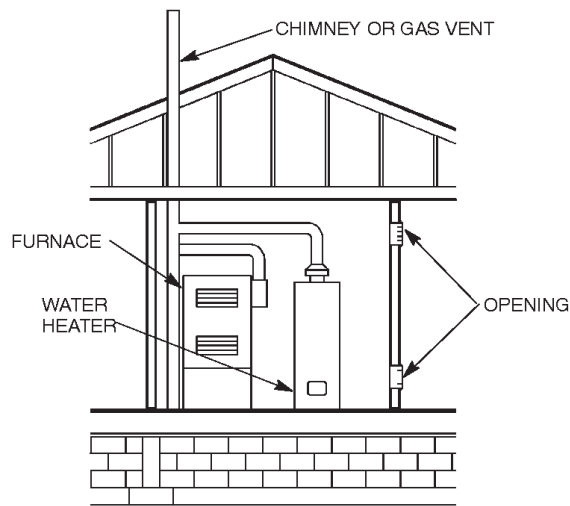
$I_{\text{other}}$  = All appliances other than fan assisted (input in Btu/h).

$I_{\text{fan}}$  = Fan-assisted appliance (input in Btu/h).

$ACH$  = Air change per hour (percent of volume of space exchanged per hour, expressed as a decimal).

For purposes of this calculation, an infiltration rate greater than 0.60 ACH shall not be used in Equations 24-1 and 24-2.

**G2407.5.3 Indoor opening size and location.** Openings used to connect indoor spaces shall be sized and located in accordance with Sections G2407.5.3.1 and G2407.5.3.2 (see Figure G2407.5.3).



**FIGURE G2407.5.3**  
**ALL AIR FROM INSIDE THE BUILDING**  
(see Section 2407.5.3)

**G2407.5.3.1 Combining spaces on the same story.** Each opening shall have a minimum free area of 1 square inch per 1,000 Btu/h (2,200 mm<sup>2</sup>/kW) of the total input rating of all gas utilization equipment in the space, but not less than 100 square inches (0.06 m<sup>2</sup>). One opening shall commence within 12 inches (305 mm) of the top and one opening shall commence within 12 inches (305 mm) of the bottom of the enclosure. The minimum dimension of air openings shall be not less than 3 inches (76 mm).

**G2407.5.3.2 Combining spaces in different stories.** The volumes of spaces in different stories shall be considered as communicating spaces where such spaces are connected by one or more openings in doors or floors having a total minimum free area of 2 square inches per 1,000 Btu/h (4402 mm<sup>2</sup>/kW) of total input rating of all gas utilization equipment.

**G2407.6 Outdoor combustion air.** Outdoor combustion air shall be provided through opening(s) to the outdoors in accordance with Section G2407.6.1 or G2407.6.2. The minimum dimension of air openings shall be not less than 3 inches (76 mm).

**G2407.6.1 Two-permanent-openings method.** Two permanent openings, one commencing within 12 inches (305 mm) of the top and one commencing within 12 inches (305 mm) of the bottom of the enclosure, shall be provided. The openings shall communicate directly, or by ducts, with the outdoors or spaces that freely communicate with the outdoors.

**FUEL GAS**

Where directly communicating with the outdoors, or where communicating with the outdoors through vertical ducts, each opening shall have a minimum free area of 1 square inch per 4,000 Btu/h (550 mm<sup>2</sup>/kW) of total input rating of all equipment in the enclosure [see Figures G2407.6.1(1) and G2407.6.1(2)].

Where communicating with the outdoors through horizontal ducts, each opening shall have a minimum free area of not less than 1 square inch per 2,000 Btu/h (1,100 mm<sup>2</sup>/kW) of total input rating of all equipment in the enclosure [see Figure G2407.6.1(3)].

**G2407.6.2 One-permanent-opening method.** One permanent opening, commencing within 12 inches (305 mm) of the top of the enclosure, shall be provided. The equipment shall have clearances of at least 1 inch (25 mm) from the sides and back and 6 inches (152 mm) from the front of the appliance. The opening shall directly communicate with the outdoors or through a vertical or horizontal duct to the outdoors or spaces that freely communicate with the outdoors [see Figure G2407.6.2] and shall have a minimum free area of 1 square inch per 3,000 Btu/h (734 mm<sup>2</sup>/kW) of the total input rating of all equipment located in the enclosure, and not less than the sum of the areas of all vent connectors in the space.

**G2407.7 Combination indoor and outdoor combustion air.** The use of a combination of indoor and outdoor combustion air shall be in accordance with Sections G2407.7.1 through G2407.7.3.

**G2407.7.1 Indoor openings.** Where used, openings connecting the interior spaces shall comply with Section G2407.5.3.

**G2407.7.2 Outdoor opening location.** Outdoor opening(s) shall be located in accordance with Section G2407.6.

**G2407.7.3 Outdoor opening(s) size.** The outdoor opening(s) size shall be calculated in accordance with the following:

1. The ratio of interior spaces shall be the available volume of all communicating spaces divided by the required volume.
2. The outdoor size reduction factor shall be one minus the ratio of interior spaces.
3. The minimum size of outdoor opening(s) shall be the full size of outdoor opening(s) calculated in accordance with Section G2407.6, multiplied by the reduction factor. The minimum dimension of air openings shall be not less than 3 inches (76 mm).

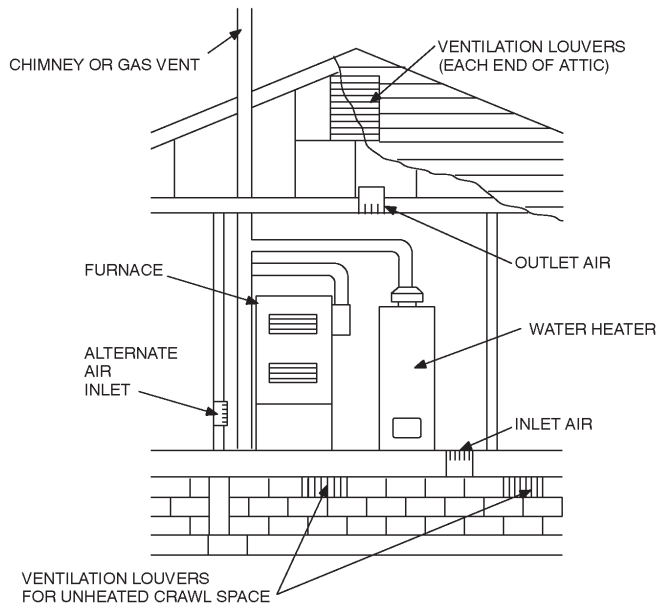
**G2407.8 Engineered installations.** Engineered combustion air installations shall provide an adequate supply of combustion, ventilation and dilution air and shall be approved.

**G2407.9 Mechanical combustion air supply.** Where all combustion air is provided by a mechanical air supply system, the combustion air shall be supplied from the outdoors at a rate not less than 0.35 cubic feet per minute per 1,000 Btu/h (0.034 m<sup>3</sup>/min per kW) of total input rating of all appliances located within the space.

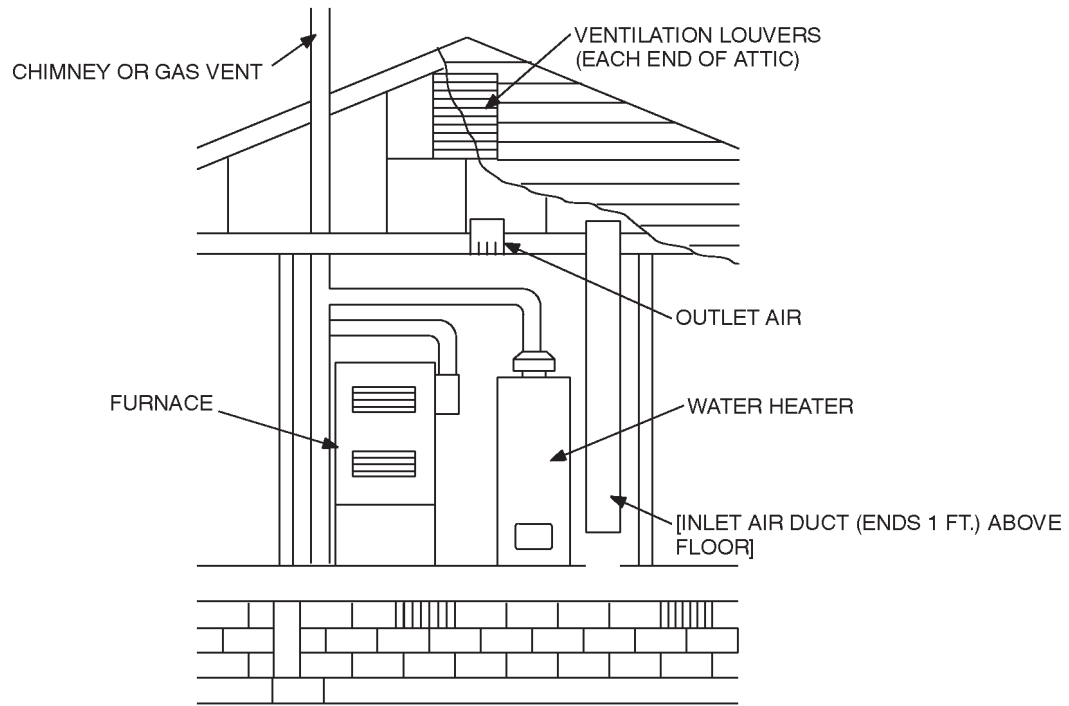
**G2407.9.1 Makeup air.** Where exhaust fans are installed, makeup air shall be provided to replace the exhausted air.

**G2407.9.2 Appliance interlock.** Each of the appliances served shall be interlocked with the mechanical air supply system to prevent main burner operation when the mechanical air supply system is not in operation.

**G2407.9.3 Combined combustion air and ventilation air system.** Where combustion air is provided by the building's mechanical ventilation system, the system shall provide the specified combustion air rate in addition to the required ventilation air.

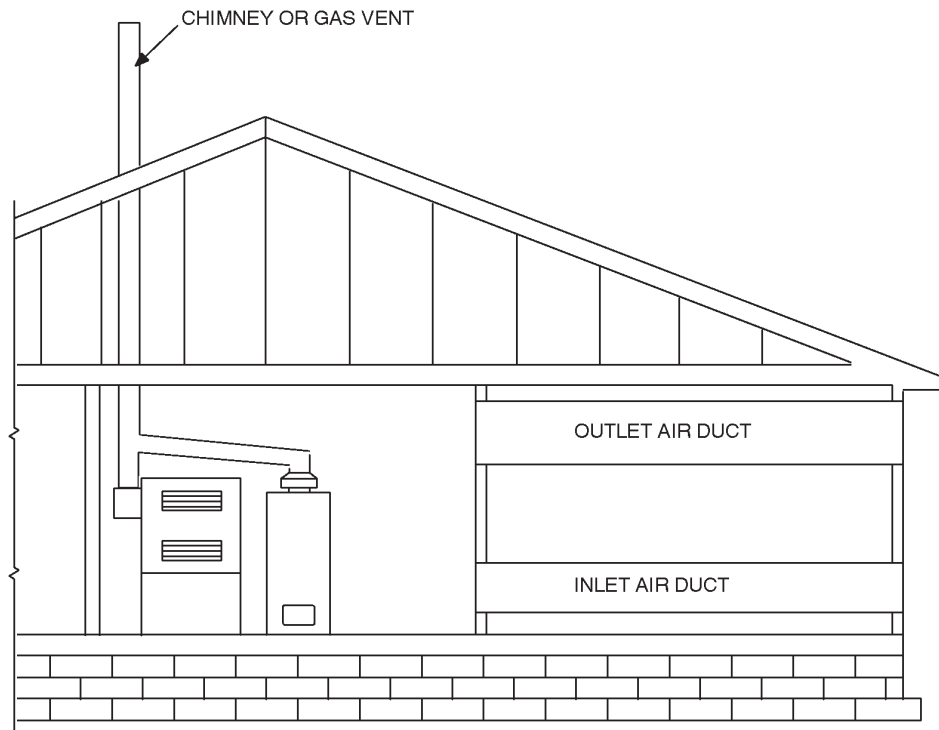


**FIGURE G2407.6.1(1)**  
**ALL AIR FROM OUTDOOR—INLET AIR FROM VENTILATED CRAWL SPACE AND OUTLET AIR TO VENTILATED ATTIC (see Section G2407.6.1)**



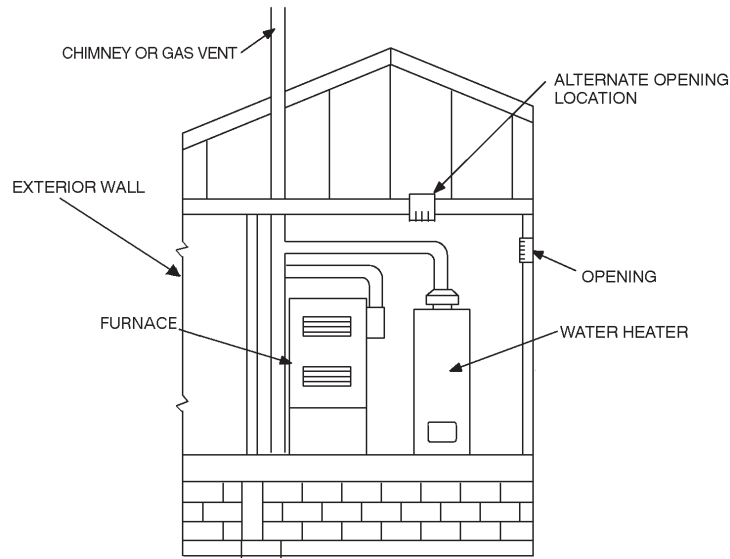
For SI: 1 foot = 304.8 mm.

**FIGURE G2407.6.1(2)**  
**ALL AIR FROM OUTDOORS THROUGH VENTILATED ATTIC**  
(see Section G2407.6.1)



**FIGURE G2407.6.1(3)**  
**ALL AIR FROM OUTDOORS**  
(see Section G2407.6.1)

FUEL GAS



**FIGURE G2407.6.2**  
**SINGLE COMBUSTION AIR OPENING—ALL AIR FROM OUTDOORS**  
 (see Section G2407.6.2.)

**G2407.9.4 Connection to the return air system.** The duct(s) admitting outdoor air may be connected to the return air side of the heating system. This duct shall have a free area of at least 1 square inch per 5,000 Btu/h (0.440 mm<sup>2</sup>W) of total input of all appliances in the space. The opening in the return air duct shall be of the same minimum cross-sectional area as the required free area of the duct(s) admitting outside air. This opening shall be located in the appliance room or in an area freely communicating with the appliance room.

**G2407.10 Louvers and grilles.** The required size of openings for combustion and dilution air shall be based on the net free area of each opening. Where the free area through a design of louver, grille or screen is known, it shall be used in calculating the size opening required to provide the free area specified. Where the design and free area of louvers and grilles are not known, it shall be assumed that wood louvers will have 25-percent free area and metal louvers and grilles will have 75-percent free area. Screens shall have a mesh size not smaller than 1/4 inch (6 mm). Nonmotorized louvers and grilles shall be fixed in the open position. Motorized louvers shall be interlocked with the equipment so that they are proven to be in the full open position prior to main burner ignition and during main burner operation. Means shall be provided to prevent the main burner from igniting if the louvers fail to open during burner startup and to shut down the main burner if the louvers close during operation.

**G2407.11 Combustion air ducts.** Combustion air ducts shall comply with all of the following:

1. Ducts shall be of galvanized steel complying with Chapter 16 or of equivalent corrosion-resistant material approved for this application.

**Exception:** Within dwellings units, unobstructed stud and joist spaces shall not be prohibited from conveying combustion air, provided that not more than one required fireblock is removed.

2. Ducts shall terminate in an unobstructed space allowing free movement of combustion air to the appliances.
3. Ducts shall serve a single enclosure.
4. Ducts shall not serve both upper and lower combustion air openings where both such openings are used. The separation between ducts serving upper and lower combustion air openings shall be maintained to the source of combustion air.
5. Ducts shall not be screened where terminating in an attic space.
6. Horizontal upper combustion air ducts shall not slope downward toward the source of combustion air.
7. The remaining space surrounding a chimney liner, gas vent, special gas vent or plastic piping installed within a masonry, metal or factory-built chimney shall not be used to supply combustion air.  
**Exception:** Direct-vent gas-fired appliances designed for installation in a solid fuel-burning fireplace where installed in accordance with the listing and the manufacturer's instructions.
8. Combustion air intake openings located on the exterior of a building shall have the lowest side of such openings located not less than 12 inches (305 mm) vertically from the adjoining grade level.
9. Have the same cross-sectional areas as the free area of the openings to which they connect.

**SECTION G2408**  
**INSTALLATION**

**G2408.1 General.** Equipment and appliances shall be installed as required by the terms of their approval, in accordance with the conditions of listing, the manufacturer's instructions and this code. Manufacturers' installation instructions shall be

available on the job site at the time of inspection. Where a code provision is less restrictive than the conditions of the listing of the equipment or appliance or the manufacturer's installation instructions, the conditions of the listing and the manufacturer's installation instructions shall apply.

Unlisted appliances approved in accordance with Section G2404.3 shall be limited to uses recommended by the manufacturer and shall be installed in accordance with the manufacturer's instructions, the provisions of this code and the requirements determined by the code official.

**G2408.2 Elevation of ignition source.** Heating and/or cooling equipment and water heaters covered by this code, located in a garage and which generate a glow, spark or flame capable of igniting flammable vapors shall be installed with sources of ignition at least 18 inches (457 mm) above the floor level.

**Exception:** Elevation of the ignition source is not required for appliances that are listed as flammable vapor resistant and for installation without elevation.

**G2408.3 Private garages.** Appliances located in private garages shall be installed with a minimum clearance of 6 feet (1829 mm) above the floor.

**Exception:** The requirements of this section shall not apply where the appliances are protected from motor vehicle impact. Figure M1307.2 contains examples of acceptable types of protection.

**G2408.4 Clearances from grade.** Equipment and appliances installed at grade level shall be supported on a level concrete slab or other approved material extending above adjoining grade or shall be suspended a minimum of 6 inches (152 mm) above adjoining grade.

**G2408.5 Clearances to combustible construction.** Heat-producing equipment and appliances shall be installed to maintain the required clearances to combustible construction as specified in the listing and manufacturer's instructions. Such clearances shall be reduced only in accordance with Section G2409. Clearances to combustibles shall include such considerations as door swing, drawer pull, overhead projections or shelving and window swing. Devices, such as door stops or limits and closers, shall not be used to provide the required clearances.

**SECTION G2409  
CLEARANCE REDUCTION**

**G2409.1 Scope.** This section shall govern the reduction in required clearances to combustible materials and combustible assemblies for chimneys, vents, appliances, devices and equipment.

**G2409.2 Reduction table.** The allowable clearance reduction shall be based on one of the methods specified in Table G2409.2 or shall utilize an assembly listed for such application. Where required clearances are not listed in Table G2409.2, the reduced clearances shall be determined by linear interpolation between the distances listed in the table. Reduced clearances shall not be derived by extrapolation below the range of the table. The reduction of the required clearances to combustibles for listed and labeled appliances and equipment shall be in ac-

cordance with the requirements of this section except that such clearances shall not be reduced where reduction is specifically prohibited by the terms of the appliance or equipment listing [see Figures G2409.2(1) and G2409.2(2)].

**G2409.3 Clearances for indoor air-conditioning equipment.** Clearance requirements for indoor air-conditioning equipment shall comply with Sections G2409.3.1 through G2409.3.5.

**G2409.3.1 Equipment installed in rooms that are large in comparison with the size of the equipment.** Air-conditioning equipment installed in rooms that are large in comparison with the size of the equipment shall be installed with clearances per the terms of their listing and the manufacturer's instructions.

**G2409.3.2 Equipment installed in rooms that are not large in comparison with the size of the equipment.** Air-conditioning equipment installed in rooms that are not large (such as alcoves and closets) in comparison with the size of the equipment shall be listed for such installations and installed in accordance with the manufacturer's instructions. Listed clearances shall not be reduced by the protection methods described in Table G2409.2, regardless of whether the enclosure is of combustible or noncombustible material.

**G2409.3.3 Clearance reduction.** Air-conditioning equipment installed in rooms that are large in comparison with the size of the equipment shall be permitted to be installed with reduced clearances to combustible material provided the combustible material or equipment is protected as described in Table G2409.2

**G2409.3.4 Plenum clearances.** Where the furnace plenum is adjacent to plaster on metal lath or noncombustible material attached to combustible material, the clearance shall be measured to the surface of the plaster or other noncombustible finish where the clearance specified is 2 inches (51 mm) or less.

**G2409.3.5 Clearance from supply ducts.** Air-conditioning equipment shall have the clearance from supply ducts within 3 feet (914 mm) of the furnace plenum be not less than that specified from the furnace plenum. No clearance is necessary beyond this distance.

**G2409.4 Central heating furnaces.** Clearance requirements for central heating furnaces shall comply with Sections G2409.4.1 through G2409.4.6. The clearance to this equipment shall not interfere with combustion air, draft hood clearance and relief, and accessibility for servicing.

**G2409.4.1 Equipment installed in rooms that are large in comparison with the size of the equipment.** Central heating furnaces installed in rooms large in comparison with the size of the equipment shall be installed with clearances per terms of their listing and the manufacturer's instructions.

**G2409.4.2 Equipment installed in rooms that are not large in comparison with the size of the equipment.** Central heating furnaces installed in rooms that are not large (such as alcoves and closets) in comparison with the size of the equipment shall be listed for such installations. Listed

## FUEL GAS

clearances shall not be reduced by the protection methods described in Table G2409.2 and illustrated in Figures G2409.2(1) and G2409.2(2), regardless of whether the enclosure is of combustible or noncombustible material.

**G2409.4.3 Clearance reduction.** Central heating furnaces installed in rooms that are large in comparison with the size of the equipment shall be permitted to be installed with reduced clearances to combustible material provided the combustible material or equipment is protected as described in Table G2409.2.

**G2409.4.4 Plenum clearances.** Where the furnace plenum is adjacent to plaster on metal lath or noncombustible material attached to combustible material, the clearance shall be measured to the surface of the plaster or other noncombustible finish where the clearance specified is 2 inches (51 mm) or less.

**G2409.4.5 Clearance from supply ducts.** Central-heating furnaces shall have the clearance from supply ducts within 3 feet (914 mm) of the furnace plenum be not less than that specified from the furnace plenum. No clearance is necessary beyond this distance.

**G2409.4.6 Clearance for servicing equipment.** Front clearance shall be sufficient for servicing the burner and the furnace.

**G2412.2 Liquefied petroleum gas storage.** The storage system for liquefied petroleum gas shall be designed and installed in accordance with the *Fire Code* and NFPA 58.

**G2412.2.1 Notice of installation.** A “Notice of Installation” is required by the state fire marshal for all LP-gas tank installations. For installation requirements of LP-gas tanks and tubing or piping up to the first stage regulator, see Article 82 of the *Fire Code*.

**G2412.3 Modifications to existing systems.** In modifying or adding to existing piping systems, sizes shall be maintained in accordance with this chapter.

**G2412.4 Additional appliances.** Where an additional appliance is to be served, the existing piping shall be checked to determine if it has adequate capacity for all appliances served. If inadequate, the existing system shall be enlarged as required or separate piping of adequate capacity shall be provided.

**G2412.5 Identification.** For other than black steel pipe, exposed piping shall be identified by a yellow label marked “Gas” in black letters. The marking shall be spaced at intervals not exceeding 5 feet (1524 mm). The marking shall not be required on pipe located in the same room as the equipment served.

**G2412.6 Interconnections.** Where two or more meters are installed on the same premises, but supply separate consumers, the piping systems shall not be interconnected on the outlet side of the meters.

**G2412.7 Piping meter identification.** Piping from multiple meter installations shall be marked with an approved permanent identification by the installer so that the piping system supplied by each meter is readily identifiable.

**G2412.8 Minimum sizes.** All pipe utilized for the installation, extension and alteration of any piping system shall be sized to supply the full number of outlets for the intended purpose and shall be sized in accordance with Section G2413.

### SECTION G2410 ELECTRICAL

**G2410.1 Grounding.** Gas piping shall not be used as a grounding electrode.

**G2410.2 Connections.** Electrical connections between gas utilization equipment and the building wiring, including the grounding of the equipment, shall conform to Chapters 33 through 42.

### SECTION G2411 ELECTRICAL BONDING

**G2411.1 Gas pipe bonding.** Electrical bonding of gas piping systems shall be in accordance with Section E35-250-104(B).

### SECTION G2412 GENERAL

**G2412.1 Scope.** This section shall govern the design, installation, and modification of fuel-gas piping systems. The applicability of this code to piping systems extends from the point of delivery to the connections with the equipment and includes the design, materials, components, fabrication, assembly, installation, testing, and inspection of such piping systems.

**G2412.1.1 Utility piping systems located within buildings.** Utility service piping located within buildings shall be installed in accordance with the provisions of this code.

### SECTION G2413 PIPE SIZING

**G2413.1 General considerations.** Piping systems shall be of such size and so installed as to provide a supply of gas sufficient to meet the maximum demand without undue loss of pressure between the point of delivery and the gas utilization equipment.

**G2413.2 Maximum gas demand.** The volume of gas to be provided in cubic feet per hour shall be determined directly from the manufacturer’s input ratings of the gas utilization equipment served. Where input rating is not indicated, the gas supplier, equipment manufacturer or a qualified agency shall be contacted, or the rating from Table G2413.2 shall be used for estimating the volume of gas to be supplied.

The total connected hourly load shall be used as the basis for piping sizing assuming that all equipment could be operating at full capacity simultaneously. Where a diversity of load can be established, pipe sizing shall be permitted to be based on such loads.

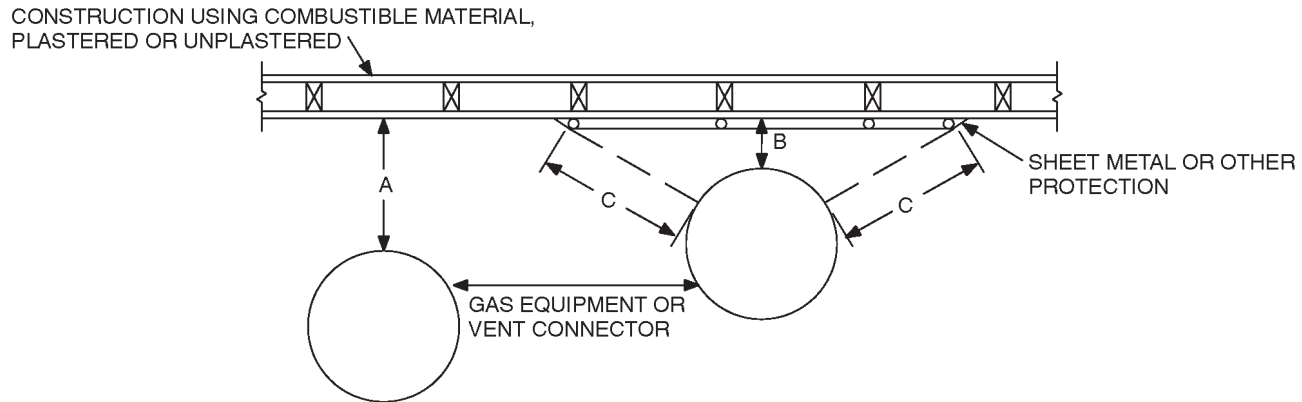
**TABLE G2409.2**  
**REDUCTION OF CLEARANCES WITH SPECIFIED FORMS OF PROTECTION<sup>a,b,c,d,e,f,g,h,i,j,k</sup>**

TYPE OF PROTECTION APPLIED TO AND COVERING ALL SURFACES OF COMBUSTIBLE MATERIAL WITHIN THE DISTANCE SPECIFIED AS THE REQUIRED CLEARANCE WITH NO PROTECTION [see Figures G2409.2(1) and G2409.2(2)]	WHERE THE REQUIRED CLEARANCE WITH NO PROTECTION FROM APPLIANCE, VENT CONNECTOR OR SINGLE WALL METAL PIPE IS:									
	36 (inches)		18 (inches)		12 (inches)		9 (inches)		6 (inches)	
	Allowable clearances with specified protection (inches)									
	Use Column 1 for clearances above appliance or horizontal connector. Use Column 2 for clearances from appliance, vertical connector and single-wall metal pipe.									
	Above Column 1	Sides and rear Column 2	Above Column 1	Sides and rear Column 2	Above Column 1	Sides and rear Column 2	Above Column 1	Sides and rear Column 2	Above Column 1	Sides and rear Column 2
3.5-inch thick masonry wall without ventilated air space	—	24	—	12	—	9	—	6	—	5
0.5-inch insulation board over 1-in. glass fiber or mineral wool batts	24	18	12	9	9	6	6	5	4	3
0.024-inch (24 gage) sheet metal over 1-inch glass fiber or mineral wool batts reinforced with wire on rear face with ventilated air space	18	12	9	6	6	4	5	3	3	3
3.5-inch thick masonry wall with ventilated air space	—	12	—	6	—	6	—	6	—	6
0.024-inch (24 gage) sheet metal with ventilated air space	18	12	9	6	6	4	5	3	3	2
0.5-inch thick insulation board with ventilated air space	18	12	9	6	6	4	5	3	3	3
0.024-inch (24 gage) sheet metal with ventilated air space over 0.024-inch (24 gage) sheet metal with ventilated air space	18	12	9	6	6	4	5	3	3	3
1-inch glass fiber or mineral wool batts sandwiched between two sheets 0.024-inch (24 gage) sheet metal with ventilated air space	18	12	9	6	6	4	5	3	3	3

For SI: 1 inch = 25.4 mm, °C = [(°F - 32)/1.8], 1 pound per cubic foot = 16.02 kg/m<sup>3</sup>, 1 Btu per inch per square foot per hour per °F = 0.144 W/m<sup>2</sup> · K.

- a. Reduction of clearances from combustible materials shall not interfere with combustion air, draft hood clearance and relief, and accessibility of servicing.
- b. All clearances shall be measured from the outer surface of the combustible material to the nearest point on the surface of the appliance, disregarding any intervening protection applied to the combustible material.
- c. Spacers and ties shall be of noncombustible material. No spacer or tie shall be used directly opposite an appliance or connector.
- d. For all clearance reduction systems using a ventilated airspace, adequate provision for air circulation shall be provided as described [see Figure 2409.2(2)].
- e. There shall be at least 1 inch between clearance reduction systems and combustible walls and ceilings for reduction systems using ventilated airspace.
- f. Where a wall protector is mounted on a single flat wall away from corners, it shall have a minimum 1-inch air gap. To provide air circulation, the bottom and top edges, or only the side and top edges, or all edges shall be left open.
- g. Mineral wool batts (blanket or board) shall have a minimum density of 8 pounds per cubic foot and a minimum melting point of 1,500°F.
- h. Insulation material used as part of a clearance reduction system shall have a thermal conductivity of 1.0 Btu per inch per square foot per hour per °F or less.
- i. There shall be at least 1 inch between the appliance and the protector. In no case shall the clearance between the appliance and the combustible surface be reduced below that allowed in this table.
- j. All clearances and thicknesses are minimum; larger clearances and thicknesses are acceptable.
- k. Listed single-wall connectors shall be installed in accordance with the terms of their listing and the manufacturer's instructions.

### FUEL GAS

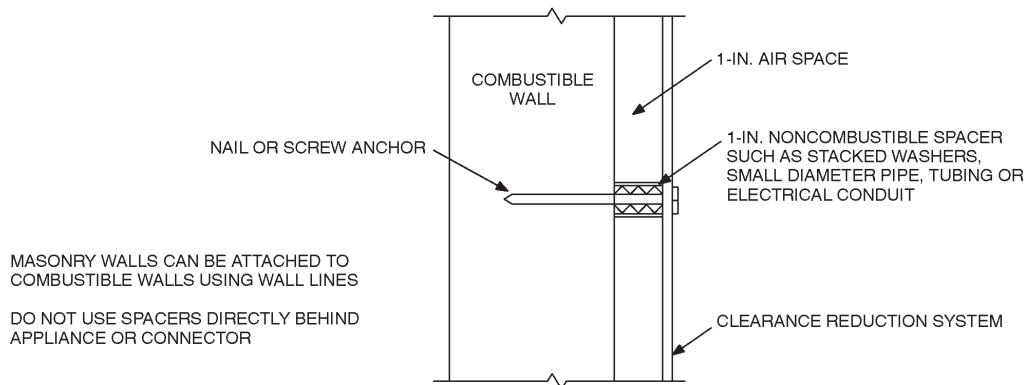
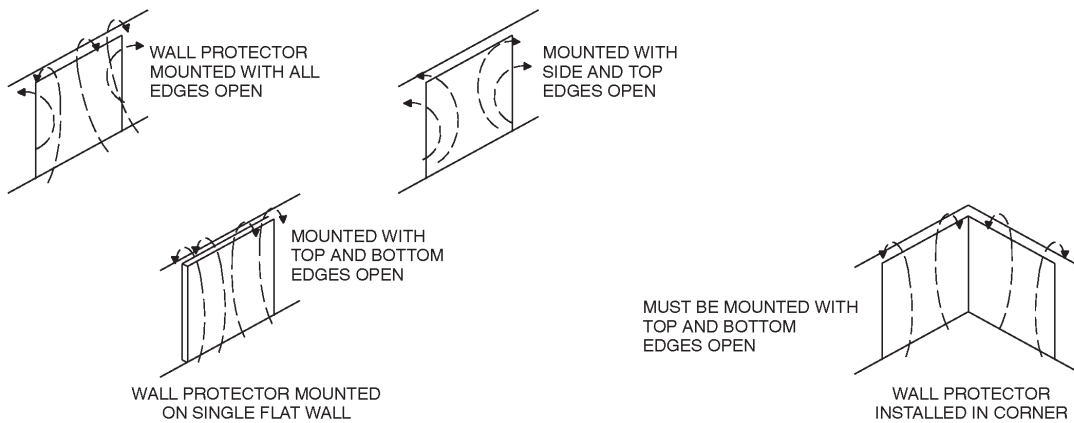


#### NOTES:

"A" equals the clearance with no protection.

"B" equals the reduced clearance permitted in accordance with Table G2409.2. The protection applied to the construction using combustible material shall extend far enough in each direction to make "C" equal to "A."

**FIGURE G2409.2(1)  
EXTENT OF PROTECTION NECESSARY TO REDUCE CLEARANCES  
FROM GAS EQUIPMENT OR VENT CONNECTORS**



For SI: 1 inch = 25.4 mm.

**FIGURE G2409.2(2)  
WALL PROTECTOR CLEARANCE REDUCTION SYSTEM**

**TABLE G2413.2  
APPROXIMATE GAS INPUT FOR TYPICAL APPLIANCES**

APPLIANCE	INPUT BTU/H (Approx.)
<b>Space Heating Units</b>	
Hydronic boiler	
Single family	100,000
Multifamily, per unit	60,000
Warm-air furnace	
Single family	100,000
Multifamily, per unit	60,000
<b>Space and Water Heating Units</b>	
Hydronic boiler	
Single family	120,000
Multifamily, per unit	75,000
<b>Water Heating Appliances</b>	
Water heater, automatic instantaneous	35,000
Capacity at 2 gal./minute	142,800
Capacity at 4 gal./minute	285,000
Capacity at 6 gal./minute	428,400
Water heater, automatic storage, 30- to 40-gal. tank	35,000
Water heater, automatic storage, 50-gal. tank	50,000
Water heater, domestic, circulating or side-arm	35,000
<b>Cooking Appliances</b>	
Built-in oven or broiler unit, domestic	25,000
Built-in top unit, domestic	40,000
Range, free-standing, domestic	65,000
<b>Other Appliances</b>	
Barbecue	40,000
Clothes dryer, Type 1 (domestic)	35,000
Gas fireplace, direct vent	40,000
Gas light	2,500
Gas log	80,000
Refrigerator	3,000

For SI: 1 British thermal unit per hour = 0.293 W, 1 gallon = 3.785 L, 1 gallon per minute = 3.785 L/m.

**G2413.3 Sizing.** Gas piping shall be sized in accordance with one of the following:

1. Pipe sizing tables or sizing equations in accordance with Section G2413.4.
2. The sizing tables included in a listed piping system's manufacturer's installation instructions.
3. Other approved methods (see Appendix A for sizing examples).

**G2413.4 Sizing tables and equations.** Where Tables G2413.4(1) through G2413.4(6) are used to size piping or tubing, the pipe length shall be determined in accordance with Section G2413.4.1, G2413.4.2 or G2413.4.3.

Where Equations 24-3 and 24-4 are used to size piping or tubing, the pipe or tubing shall have smooth inside walls and the pipe length shall be determined in accordance with Section G2413.4.1, G2413.4.2 or G2413.4.3.

1. Low-pressure gas equation [Less than 1.5 pounds per square inch (psi) (10.3 kPa)]:

$$D = \frac{Q^{0.381}}{19.17 \left( \frac{\Delta H}{C_r \times L} \right)^{0.206}} \quad \text{(Equation 24-3)}$$

2. High-pressure gas equation [1.5 psi (10.3 kPa) and above]:

$$D = \frac{Q^{0.381}}{18.93 \left[ \frac{(P_1^2 - P_2^2) \times Y}{C_r \times L} \right]^{0.206}} \quad \text{(Equation 24-4)}$$

where:

- D = Inside diameter of pipe, inches (mm).
- Q = Input rate appliance(s), cubic feet per hour at 60°F (16°C) and 30-inch mercury column
- P<sub>1</sub> = Upstream pressure, psia (P<sub>1</sub> + 14.7)
- P<sub>2</sub> = Downstream pressure, psia (P<sub>2</sub> + 14.7)
- L = Equivalent length of pipe, feet
- ΔH = Pressure drop, inch water column (27.7 inch water column = 1 psi)

**TABLE G2413.4  
C<sub>r</sub> AND Y VALUES FOR NATURAL GAS AND  
UNDILUTED PROPANE AT STANDARD CONDITIONS**

GAS	EQUATION FACTORS	
	C <sub>r</sub>	Y
Natural gas	0.6094	0.9992
Undiluted propane	1.2462	0.9910

For SI: 1 cubic foot = 0.028 m<sup>3</sup>, 1 foot = 305 mm, 1 inch water column = 0.249 kPa, 1 pound per square inch = 6.895 kPa, 1 British thermal unit per hour = 0.293 W.

**G2413.4.1 Longest length method.** The pipe size of each section of gas piping shall be determined using the longest length of piping from the point of delivery to the most remote outlet and the load of the section.

**G2413.4.2 Branch length method.** Pipe shall be sized as follows:

1. Pipe size of each section of the longest pipe run from the point of delivery to the most remote outlet shall be determined using the longest run of piping and the load of the section.
2. The pipe size of each section of branch piping not previously sized shall be determined using the length of piping from the point of delivery to the most remote outlet in each branch and the load of the section.

**G2413.4.3 Hybrid pressure.** The pipe size for each section of higher pressure gas piping shall be determined using the

## FUEL GAS

longest length of piping from the point of delivery to the most remote line pressure regulator. The pipe size from the line pressure regulator to each outlet shall be determined using the length of piping from the regulator to the most remote outlet served by the regulator.

**G2413.5 Allowable pressure drop.** The design pressure loss in any piping system under maximum probable flow conditions, from the point of delivery to the inlet connection of the equipment, shall be such that the supply pressure at the equipment is greater than the minimum pressure required for proper equipment operation.

**G2413.6 Maximum design operating pressure.** The maximum design operating pressure for piping systems located inside buildings shall not exceed 5 psig (34 kPa gauge) except where one or more of the following conditions are met:

1. The piping system is welded.
2. The piping is located in a ventilated chase or otherwise enclosed for protection against accidental gas accumulation.
3. The piping is a temporary installation for buildings under construction.

**G2413.6.1 Liquefied petroleum gas systems.** The operating pressure for undiluted LP-gas systems shall not exceed 20 psig (140 kPa gauge). Buildings having systems designed to operate below -5°F (-21°C) or with butane or a propane-butane mix shall be designed to either accommodate liquid LP-gas or prevent LP-gas vapor from condensing back into a liquid.

**G2413.6.2 License requirements.** LP-gas installers must be licensed by the state fire marshal in accordance with ORS 480.432 through 480.436.

### SECTION G2414 PIPING MATERIALS

**G2414.1 General.** Materials used for piping systems shall comply with the requirements of this chapter or shall be approved.

**G2414.2 Used materials.** Pipe, fittings, valves or other materials shall not be used again unless they are free of foreign materials and have been ascertained to be adequate for the service intended.

**G2414.3 Other materials.** Material not covered by the standards specifications listed herein shall be investigated and tested to determine that it is safe and suitable for the proposed service, and, in addition, shall be recommended for that service by the manufacturer and shall be approved by the code official.

**G2414.4 Metallic pipe.** Metallic pipe shall comply with Sections G2414.4.1 and G2414.4.2.

**G2414.4.1 Cast iron.** Cast-iron pipe shall not be used.

**G2414.4.2 Steel.** Steel and wrought-iron pipe shall be at least of standard weight (Schedule 40) and shall comply with one of the following:

1. ASME B 36.10, 10M; or
2. ASTM A 53; or
3. ASTM A 106.

**G2414.5 Metallic tubing.** Seamless copper, aluminum alloy or steel tubing shall be permitted to be used with gases not corrosive to such material.

**G2414.5.1** Steel tubing shall comply with ASTM A 539 or ASTM A 254.

**G2414.5.2 Copper tubing.** Copper tubing shall comply with standard Type K or L of ASTM B 88 or ASTM B 280.

Copper and brass tubing shall not be used if the gas contains more than an average of 0.3 grains of hydrogen sulfide per 100 standard cubic feet of gas (0.7 milligrams per 100 liters).

**G2414.5.3 Corrugated stainless steel tubing.** Corrugated stainless steel tubing shall be tested and listed in compliance with the construction, installation and performance requirements of ANSI LC 1/CSA 6.26.

**G2414.6 Plastic pipe, tubing and fittings.** Plastic pipe, tubing and fittings shall be used outside underground only and shall conform with ASTM D 2513. Pipe to be used shall be marked "gas" and "ASTM D 2513."

**G2414.6.1 Anodeless risers.** Anodeless risers shall comply with the following:

1. Factory-assembled anodeless risers shall be recommended by the manufacturer for the gas used and shall be leak-tested by the manufacturer in accordance with written procedures.
2. Service head adapters and field-assembled anodeless risers incorporating service head adapters shall be recommended by the manufacturer for the gas used by the manufacturer and shall be designed certified to meet the requirements of Category I of ASTM D 2513, and U.S. Department of Transportation, Code of Federal Regulations, Title 49, Part 192.281(e). The manufacturer shall provide the user qualified installation instructions as prescribed by the U.S. Department of Transportation, Code of Federal Regulations, Title 49, Part 192.283(b).

**G2414.6.2 LP-gas systems.** The use of plastic pipe, tubing and fittings in undiluted liquefied petroleum gas piping systems shall be in accordance with NFPA 58.

**G2414.7 Workmanship and defects.** Pipe or tubing and fittings shall be clear and free from cutting burrs and defects in structure or threading, and shall be thoroughly brushed, and chip and scale blown.

Defects in pipe or tubing or fittings shall not be repaired. Defective pipe, tubing or fittings shall be replaced. (See Section G2417.1.2.)

**G2414.8 Protective coating.** Where in contact with material or atmosphere exerting a corrosive action, metallic piping and fittings coated with a corrosion-resistant material shall be used. External or internal coatings or linings used on piping or components shall not be considered as adding strength.

**G2414.9 Metallic pipe threads.** Metallic pipe and fitting threads shall be taper pipe threads and shall comply with ASME B1.20.1.

FUEL GAS

**TABLE G2413.4(1)  
 SCHEDULE 40 METALLIC PIPE**

<b>Gas</b>	Natural
<b>Inlet Pressure</b>	0.5 psi or less
<b>Pressure Drop</b>	0.5 inch WC
<b>Specific Gravity</b>	0.60

PIPE SIZE (in.)						
Nominal	1/4	3/8	1/2	3/4	1	1 1/4
Actual ID	0.364	0.493	0.622	0.824	1.049	1.380
Length (ft)	Maximum Capacity in Cubic Feet of Gas per Hour					
10	43	95	175	360	680	1,400
20	29	65	120	250	465	950
30	24	52	97	200	375	770
40	20	45	82	170	320	660
50	18	40	73	151	285	580
60	16	36	66	138	260	530
70	15	33	61	125	240	490
80	14	31	57	118	220	460
90	13	29	53	110	205	430
100	12	27	50	103	195	400
125	11	24	44	93	175	360
150	10	22	40	84	160	325

For SI: 1 inch = 25.4 mm, 1 foot = 304.8 mm, 1 cubic foot per hour = 0.0283m<sup>3</sup>/h, 1 pound per square inch = 6.895 kPa, 1-inch water column = 0.2488 kPa.

**TABLE G2413.4(2)  
 SCHEDULE 40 METALLIC PIPE**

<b>Gas</b>	Natural
<b>Inlet Pressure</b>	2.0 psi
<b>Pressure Drop</b>	1.0 psi
<b>Specific Gravity</b>	0.60

PIPE SIZE (in.)				
Nominal	1/2	3/4	1	1 1/4
Actual ID	0.622	0.824	1.049	1.380
Length (ft)	Maximum Capacity in Cubic Feet of Gas per Hour			
10	1,506	3,041	5,561	11,415
20	1,065	2,150	3,932	8,072
30	869	1,756	3,211	6,591
40	753	1,521	2,781	5,708
50	673	1,360	2,487	5,105
60	615	1,241	2,270	4,660
70	569	1,150	2,102	4,315
80	532	1,075	1,966	4,036
90	502	1,014	1,854	3,805
100	462	934	1,708	3,508
125	414	836	1,528	3,138
150	372	751	1,373	2,817

For SI: 1 inch = 25.4 mm, 1 foot = 304.8 mm, 1 cubic foot per hour = 0.0283m<sup>3</sup>/h, 1 pound per square inch = 6.895 kPa.

**FUEL GAS**

**TABLE G2413.4(3)  
 SEMI-RIGID COPPER TUBING**

<b>Gas</b>	Natural
<b>Inlet Pressure</b>	0.5 psi or less
<b>Pressure Drop</b>	0.5 inch WC
<b>Specific Gravity</b>	0.60

Nominal	K & L ACR	TUBE SIZE (in.)					
		1/4	3/8	1/2	5/8	3/4	1
		3/8	1/2	5/8	3/4	7/8	1 1/8
<b>Outside</b>		0.375	0.500	0.625	0.750	0.875	1.125
<b>Inside</b>		0.305	0.402	0.527	0.652	0.745	0.995
<b>Length (ft)</b>		<b>Maximum Capacity in Cubic Feet of Gas per Hour</b>					
10		27	55	111	195	276	590
20		18	38	77	134	190	406
30		15	30	61	107	152	326
40		13	26	53	92	131	279
50		11	23	47	82	116	247
60		10	21	42	74	105	224
70		9.3	19	39	68	96	206
80		8.6	18	36	63	90	192
90		8.1	17	34	59	84	180
100		7.6	16	32	56	79	170
125		6.8	14	28	50	70	151
150		6.1	13	26	45	64	136

Note: Table capacities are based on Type K copper tubing inside diameter (shown), which has the smallest inside diameter of the copper tubing products.  
 For SI: 1 inch = 25.4 mm, 1 foot = 304.8 mm, 1 cubic foot per hour = 0.0283 m<sup>3</sup>/h, 1 pound per square inch = 6.895 kPa, 1-inch water column = 0.2488 kPa.

FUEL GAS

**TABLE G2413.4(4)  
 SEMI-RIGID COPPER TUBING**

<b>Gas</b>	Natural
<b>Inlet Pressure</b>	2.0 psi or less
<b>Pressure Drop</b>	1.0 psi
<b>Specific Gravity</b>	0.60

Nominal	TUBE SIZE (in.)						
	K & L	1/4	3/8	1/2	5/8	3/4	1
	ACR	3/8	1/2	5/8	3/4	7/8	1 1/8
<b>Outside</b>		0.375	0.500	0.625	0.750	0.875	1.125
<b>Inside</b>		0.305	0.402	0.527	0.652	0.745	0.995
<b>Length (ft)</b>	<b>Maximum Capacity in Cubic Feet of Gas per Hour</b>						
10		245	506	1,030	1,800	2,554	5,455
20		169	348	708	1,237	1,755	3,749
30		135	279	568	993	1,409	3,011
40		116	239	486	850	1,206	2,577
50		103	212	431	754	1,069	2,284
60		93	192	391	683	969	2,069
70		86	177	359	628	891	1,904
80		80	164	334	584	829	1,771
90		75	154	314	548	778	1,662
100		71	146	296	518	735	1,570
125		63	129	263	459	651	1,391
150		57	117	238	416	590	1,260

Note: Table capacities are based on Type K copper tubing inside diameter (shown), which has the smallest inside diameter of the copper tubing products.  
 For SI: 1 inch = 25.4 mm, 1 foot = 304.8 mm, 1 cubic foot per hour = 0.0283m<sup>3</sup>/h, 1 pound per square inch = 6.895 kPa.

FUEL GAS

**TABLE G2413.4(5)  
 CORRUGATED STAINLESS STEEL TUBING (CSST)**

<b>Gas</b>	Natural
<b>Inlet Pressure</b>	0.5 psi or less
<b>Pressure Drop</b>	0.5 inch WC
<b>Specific Gravity</b>	0.60

Flow Designation	TUBE SIZE (EHD*)										
	13	15	18	19	23	25	30	31	37	46	62
<b>Length (ft)</b>	<b>Maximum Capacity in Cubic Feet of Gas per Hour</b>										
5	46	63	115	134	225	270	471	546	895	1,790	4,142
10	32	44	82	95	161	192	330	383	639	1,261	2,934
15	25	35	66	77	132	157	267	310	524	1,027	2,398
20	22	31	58	67	116	137	231	269	456	888	2,078
25	19	27	52	60	104	122	206	240	409	793	1,860
30	18	25	47	55	96	112	188	218	374	723	1,698
40	15	21	41	47	83	97	162	188	325	625	1,472
50	13	19	37	42	75	87	144	168	292	559	1,317
60	12	17	34	38	68	80	131	153	267	509	1,203
70	11	16	31	36	63	74	121	141	248	471	1,114
80	10	15	29	33	60	69	113	132	232	440	1,042
90	10	14	28	32	57	65	107	125	219	415	983
100	9	13	26	30	54	62	101	118	208	393	933
150	7	10	20	23	42	48	78	91	171	320	762
200	6	9	18	21	38	44	71	82	148	277	661
250	5	8	16	19	34	39	63	74	133	247	591
300	5	7	15	17	32	36	57	67	95	226	540

Note: Table includes losses for four 90-degree bends and two end fittings. Tubing runs with larger numbers of bends and/or fittings shall be increased by an equivalent length of tubing to the following equation:  $L = 1.3n$  where  $L$  is additional length (ft) of tubing and  $n$  is the number of additional fittings and/or bends.

\*EHD—Equivalent Hydraulic Diameter, which is a measure of the relative hydraulic efficiency between different tubing sizes. The greater the value of EHD, the greater the gas capacity of the tubing.

For SI: 1 inch = 25.4 mm, 1 foot = 304.8 mm, 1 cubic foot per hour = 0.0283 m<sup>3</sup>/h, 1 pound per square inch = 6.895 kPa, 1-inch water column = 0.2488 kPa, 1 degree = 0.01745 rad.

FUEL GAS

**TABLE G2413.4(6)  
 CORRUGATED STAINLESS STEEL TUBING (CSST)**

<b>Gas</b>	Natural
<b>Inlet Pressure</b>	2.0 psi
<b>Pressure Drop</b>	1.0 psi
<b>Specific Gravity</b>	0.60

<b>Flow Designation</b>	13	15	18	19	23	25	30	31	37	46	62
<b>Length (ft)</b>	<b>Maximum Capacity in Cubic Feet of Gas per Hour</b>										
10	270	353	587	700	1,098	1,372	2,592	2,986	4,509	9,599	21,637
25	166	220	374	444	709	876	1,620	1,869	2,887	6,041	13,715
30	151	200	342	405	650	801	1,475	1,703	2,642	5,509	12,526
40	129	172	297	351	567	696	1,273	1,470	2,297	4,763	10,855
50	115	154	266	314	510	624	1,135	1,311	2,061	4,255	9,715
75	93	124	218	257	420	512	922	1,066	1,692	3,467	7,940
80	89	120	211	249	407	496	892	1,031	1,639	3,355	7,689
100	79	107	189	222	366	445	795	920	1,471	2,997	6,881
150	64	87	155	182	302	364	646	748	1,207	2,442	5,624
200	55	75	135	157	263	317	557	645	1,049	2,111	4,874
250	49	67	121	141	236	284	497	576	941	1,886	4,362
300	44	61	110	129	217	260	453	525	862	1,720	3,983
400	38	52	96	111	189	225	390	453	749	1,487	3,452
500	34	46	86	100	170	202	348	404	552	1,329	3,089

Notes:

1. Table does not include effect of pressure drop across the line regulator. Where regulator loss exceeds  $\frac{3}{4}$  psi, DO NOT USE THIS TABLE. Consult with regulator manufacturer for pressure drops and capacity factors. Pressure drops across a regulator may vary with flow rate.
  2. CAUTION: Capacities shown in table might exceed maximum capacity for a selected regulator. Consult with regulator or tubing manufacturer for guidance.
  3. Table includes losses for four 90-degree bends and two end fittings. Tubing runs with larger numbers of bends and/or fittings shall be increased by an equivalent length of tubing to the following equation:  $L = 1.3n$  where  $L$  is additional length (ft) of tubing and  $n$  is the number of additional fittings and/or bends.
- \*EHD— Equivalent Hydraulic Diameter, which is a measure of the relative hydraulic efficiency between different tubing sizes. The greater the value of EHD, the greater the gas capacity of the tubing.

For SI: 1 inch = 25.4 mm, 1 foot = 304.8 mm, 1 cubic foot per hour = 0.0283 m<sup>3</sup>/h, 1 pound per square inch = 6.895 kPa, 1 degree = 0.01745 rad.

FUEL GAS

**G2414.9.1 Damaged threads.** Pipe with threads that are stripped, chipped, corroded or otherwise damaged shall not be used. If a weld opens during the operation of cutting or threading, that portion of the pipe shall not be used.

**G2414.9.2 Number of threads.** Field threading of metallic pipe shall be in accordance with Table G2414.9.2.

**TABLE G2414.9.2  
SPECIFICATIONS FOR THREADING METALLIC PIPE**

IRON PIPE SIZE (inches)	APPROXIMATE LENGTH OF THREADED PORTION (inches)	APPROXIMATE NO. OF THREADS TO BE CUT
1/2	3/4	10
3/4	3/4	10
1	7/8	10
1 1/4	1	11
1 1/2	1	11

For SI: 1 inch = 25.4 mm.

**G2414.9.3 Thread compounds.** Thread (joint) compounds (pipe dope) shall be resistant to the action of liquefied petroleum gas or to any other chemical constituents of the gases to be conducted through the piping.

**G2414.10 Metallic piping joints and fittings.** The type of piping joint used shall be suitable for the pressure-temperature conditions and shall be selected giving consideration to joint tightness and mechanical strength under the service conditions. The joint shall be able to sustain the maximum end force due to the internal pressure and any additional forces due to temperature expansion or contraction, vibration, fatigue, or to the weight of the pipe and its contents.

**G2414.10.1 Pipe joints.** Pipe joints shall be threaded, flanged, brazed or welded. Where nonferrous pipe is brazed, the brazing materials shall have a melting point in excess of 1,000°F (538°C). Brazing alloys shall not contain more than 0.05-percent phosphorus.

**G2414.10.2 Tubing joints.** Tubing joints shall either be made with approved gas tubing fittings or be brazed with a material having a melting point in excess of 1,000°F (538°C). Brazing alloys shall not contain more than 0.05-percent phosphorus.

**G2414.10.3 Flared joints.** Flared joints shall be used only in systems constructed from nonferrous pipe and tubing where experience or tests have demonstrated that the joint is suitable for the conditions and where provisions are made in the design to prevent separation of the joints.

**G2414.10.4 Metallic fittings.** Metallic fittings, including valves, strainers and filters shall comply with the following:

1. Fittings used with steel or wrought-iron pipe shall be steel, brass, bronze, malleable iron, ductile iron or cast iron.
2. Fittings used with copper or brass pipe shall be copper, brass or bronze.
3. Cast-iron bushings shall be prohibited.

4. Special fittings. Fittings such as couplings, proprietary-type joints, saddle tees, gland-type compression fittings, and flared, flareless or compression-type tubing fittings shall be: used within the fitting manufacturer's pressure-temperature recommendations; used within the service conditions anticipated with respect to vibration, fatigue, thermal expansion or contraction; installed or braced to prevent separation of the joint by gas pressure or external physical damage; and shall be approved.

**G2414.11 Plastic piping, joints and fittings.** Plastic pipe, tubing and fittings shall be joined in accordance with the manufacturers' instructions. Such joints shall comply with the following:

1. The joints shall be designed and installed so that the longitudinal pull-out resistance of the joints will be at least equal to the tensile strength of the plastic piping material.
2. Heat-fusion joints shall be made in accordance with qualified procedures that have been established and proven by test to produce gas-tight joints at least as strong as the pipe or tubing being joined. Joints shall be made with the joining method recommended by the pipe manufacturer. Heat fusion fittings shall be marked "ASTM D 2513."
3. Where compression-type mechanical joints are used, the gasket material in the fitting shall be compatible with the plastic piping and with the gas distributed by the system. An internal tubular rigid stiffener shall be used in conjunction with the fitting. The stiffener shall be flush with the end of the pipe or tubing and shall extend at least to the outside end of the compression fitting when installed. The stiffener shall be free of rough or sharp edges and shall not be a force fit in the plastic. Split tubular stiffeners shall not be used.
4. Plastic piping joints and fittings for use in liquefied petroleum gas piping systems shall be in accordance with NFPA 58.

**SECTION G2415  
PIPING SYSTEM INSTALLATION**

**G2415.1 Prohibited locations.** Piping shall not be installed in or through a circulating air duct, clothes chute, chimney or gas vent, ventilating duct, dumbwaiter or elevator shaft.

**G2415.2 Piping in solid partitions and walls.** Concealed piping shall not be located in solid partitions and solid walls, unless installed in a chase or casing.

**G2415.3 Piping in concealed locations.** Portions of a piping system installed in concealed locations shall not have unions, tubing fittings, right and left couplings, bushings, compression couplings, and swing joints made by combinations of fittings.

**Exceptions:**

1. Tubing joined by brazing.
2. Fittings listed for use in concealed locations.

**G2415.4 Piping through foundation wall.** Underground piping, where installed below grade through the outer foundation or basement wall of a building, shall be encased in a protective

pipe sleeve. The annular space between the gas piping and the sleeve shall be sealed.

**G2415.5 Protection against physical damage.** In concealed locations, where piping other than black or galvanized steel is installed through holes or notches in wood studs, joists, rafters or similar members less than 1 inch (25 mm) from the nearest edge of the member, the pipe shall be protected by shield plates. Shield plates shall be a minimum of 0.0625-inch-thick (1.6 mm) steel, shall cover the area of the pipe where the member is notched or bored, and shall extend a minimum of 4 inches (102 mm) above sole plates, below top plates and to each side of a stud, joist or rafter.

**G2415.6 Piping in solid floors.** Piping in solid floors shall be laid in channels in the floor and covered in a manner that will allow access to the piping with a minimum amount of damage to the building. Where such piping is subject to exposure to excessive moisture or corrosive substances, the piping shall be protected in an approved manner. As an alternative to installation in channels, the piping shall be installed in a casing of Schedule 40 steel, wrought iron, PVC or ABS pipe with tightly sealed ends and joints. Both ends of such casing shall extend not less than 2 inches (51 mm) beyond the point where the pipe emerges from the floor.

**G2415.7 Above-ground piping outdoors.** All piping installed outdoors shall be elevated not less than 3½ inches (152 mm) above ground and where installed across roof surfaces, shall be elevated not less than 3½ inches (152 mm) above the roof surface. Piping installed above ground, outdoors, and installed across the surface of roofs shall be securely supported and located where it will be protected from physical damage. Where passing through an outside wall, the piping shall also be protected against corrosion by coating or wrapping with an inert material. Where piping is encased in a protective pipe sleeve, the annular space between the piping and the sleeve shall be sealed.

**G2415.8 Corrosion and covering protection.** Nonmetallic gas piping and coated and cathodically protected piping shall have a minimum of 18 inches (457 mm) of earth cover or other equivalent protection. Risers, including prefabricated risers inserted with plastic pipe, shall be metallic and shall be protected in an approved manner to a point at least 6 inches (153 mm) above grade. When a riser connects to plastic pipe underground, the horizontal metallic portion underground shall be at least 30 inches (762 mm) in length before connecting to the plastic service pipe. An approved transition fitting or adapter shall be used where the plastic joins the metallic riser.

Ferrous metals in exposed exterior locations shall be protected from corrosion in a manner approved by the building official after consulting with the gas supplier.

Ferrous pipes installed underground shall not be placed in contact with other metallic objects such as pipes or wires.

Zinc coatings (galvanizing) shall not be deemed adequate protection for piping below grade. Ferrous gas piping installed underground in exterior locations shall be protected from corrosion by either:

**G2415.8.1 Coated and cathodically protected pipe.** All gas pipe protective coatings shall be approved types, ma-

chine applied and conform to recognized standards. Field wrapping shall provide equivalent protection and is restricted to those short sections and fittings necessarily stripped for threading or welding. Underground coated and wrapped gas piping shall be cathodically protected with galvanic anodes or rectifiers and electrically isolated from the rest of the system by insulating unions 6 inches (153 mm) above grade.

**G2415.8.2 Unwrapped (bare) pipe and special covering.** Unwrapped ferrous gas piping being installed underground in exterior locations shall be protected from corrosion by being installed within a minimum 6-inch (153 mm) protective bed of sand around the gas piping, the pipe being centrally located within the sand backfill, and all such horizontal piping shall have a minimum of 18 inches (457 mm) of earth cover or other equivalent protection. Underground piping shall be electrically isolated from the rest of the system by insulating unions placed a minimum of 6 inches (153 mm) above grade.

**G2415.8.3 Electrical isolation of fuel gas piping.** Underground ferrous gas piping shall be electrically isolated from the rest of the gas system with listed or approved isolation fittings installed a minimum of 6 inches (153 mm) above grade.

**G2415.9 Minimum burial depth.** Underground piping systems shall be installed a minimum depth of 18 inches (457 mm) below grade, except as provided for in Section G2415.9.1.

**G2415.9.1 Individual outside appliances.** Individual lines to outside lights, grills or other appliances shall be installed a minimum of 8 inches (203 mm) below finished grade, provided that such installation is approved and is installed in locations not susceptible to physical damage.

**G2415.10 Trenches.** The trench shall be graded so that the pipe has a firm, substantially continuous bearing on the bottom of the trench.

**G2415.10.1 Underground gas pipe separation.** Underground gas piping shall be separated vertically or horizontally from other underground piping as follows:

1. **Sewer pipe** – not less than 18 inches (457 mm) from any underground sewer line.
2. **Water pipe** – not less than 12 inches (305 mm) from any underground water line.
3. **Drainage pipe** – not less than 12 inches (305 mm) from any underground drainage line.

**G2415.11 Piping underground beneath buildings.** Piping installed underground beneath buildings is prohibited except where the piping is encased in a conduit of wrought iron, plastic pipe, or steel pipe designed to withstand the superimposed loads. Such conduit shall extend into an occupiable portion of the building and, at the point where the conduit terminates in the building, the space between the conduit and the gas piping shall be sealed to prevent the possible entrance of any gas leakage. If the end sealing is capable of withstanding the full pressure of the gas pipe, the conduit shall be designed for the same pressure as the pipe. Such conduit shall extend not less than 4 inches (102 mm) outside the building, shall be vented above grade to the outdoors, and shall be installed so as prevent the

## FUEL GAS

entrance of water and insects. The conduit shall be protected from corrosion in accordance with Section G2415.8.

**G2415.12 Outlet closures.** Gas outlets that do not connect to appliances shall be capped gas tight.

**Exception:** Listed and labeled flush-mounted-type quick-disconnect devices and listed and labeled gas convenience outlets shall be installed in accordance with the manufacturer's installation instructions.

**G2415.13 Location of outlets.** The unthreaded portion of piping outlets shall extend not less than 1 inch (25 mm) through finished ceilings and walls and where extending through floors, outdoor patios and slabs, shall not be less than 2 inches (51 mm) above them. The outlet fitting or piping shall be securely supported. Outlets shall not be placed behind doors. Outlets shall be located in the room or space where the appliance is installed.

**Exception:** Listed and labeled flush-mounted-type quick-disconnect devices and listed and labeled gas convenience outlets shall be installed in accordance with the manufacturer's installation instructions.

**G2415.14 Plastic pipe.** The installation of plastic pipe shall comply with Sections G2415.14.1 through G2415.14.3.

**G2415.14.1 Limitations.** Plastic pipe shall be installed outside underground only. Plastic pipe shall not be used within or under any building or slab building or be operated at pressures greater than 100 psig (689 kPa) for natural gas or 30 psig (207 kPa) for LP gas.

### Exceptions:

1. Plastic pipe shall be permitted to terminate above ground outside of buildings where installed in premanufactured anodeless risers or service head adapter risers that are installed in accordance with that manufacturer's installation instructions.
2. Plastic pipe shall be permitted to terminate with a wall head adapter within buildings where the plastic pipe is inserted in a piping material for fuel gas use in buildings.
3. Plastic pipe shall be permitted under an exterior slab, such as a driveway, sidewalk or a patio, and shall be installed in accordance with the manufacturer's installation instructions and this code.

**G2415.14.2 Connections.** Connections made outside and underground between metallic and plastic piping shall be made only with transition fittings categorized as Category I in accordance with ASTM D 2513.

**G2415.14.3 Tracer.** A yellow insulated copper tracer wire or other approved conductor shall be installed adjacent to underground nonmetallic piping. Access shall be provided to the tracer wire or the tracer wire shall terminate above ground at each end of the nonmetallic piping. The tracer wire size shall not be less than 18 AWG and the insulation type shall be suitable for direct burial.

**G2415.15 Prohibited devices.** A device shall not be placed inside the piping or fittings that will reduce the cross-sectional area or otherwise obstruct the free flow of gas.

**Exception:** Approved gas filters.

**G2415.16 Testing of piping.** Before any system of piping is put in service or concealed, it shall be tested to ensure that it is gas tight. Testing, inspection and purging of piping systems shall comply with Section G2417.

## SECTION G2416

### PIPING BENDS AND CHANGES IN DIRECTION

**G2416.1 General.** Changes in direction of pipe shall be permitted to be made by the use of fittings, factory bends or field bends.

**G2416.2 Metallic pipe.** Metallic pipe bends shall comply with the following:

1. Bends shall be made only with bending equipment and procedures especially intended for that purpose.
2. All bends shall be smooth and free from buckling, cracks or other evidence of mechanical damage.
3. The longitudinal weld of the pipe shall be near the neutral axis of the bend.
4. Pipe shall not be bent through an arc of more than 90 degrees (1.6 rad).
5. The inside radius of a bend shall be not less than six times the outside diameter of the pipe.

**G2416.3 Plastic pipe.** Plastic pipe bends shall comply with the following:

1. The pipe shall not be damaged and the internal diameter of the pipe shall not be effectively reduced.
2. Joints shall not be located in pipe bends.
3. The radius of the inner curve of such bends shall not be less than 25 times the inside diameter of the pipe.
4. Where the piping manufacturer specifies the use of special bending equipment or procedures, such equipment or procedures shall be used.

## SECTION G2417

### INSPECTION, TESTING AND PURGING

**G2417.1 General.** Prior to acceptance and initial operation, all piping installations shall be inspected and pressure tested to determine that the materials, design, fabrication, and installation practices comply with the requirements of this code.

**G2417.1.1 Inspections.** Inspection shall consist of visual examination, during or after manufacture, fabrication, assembly or pressure tests as appropriate.

**G2417.1.1.1 Rough piping inspection.** This inspection shall be made after piping authorized by the permit has been installed and before such piping has been covered or concealed or a fixture or appliance has been attached thereto. This inspection shall include a determination that the gas piping size, material and installation meet the requirements of this appendix.

**G2417.1.1.2 Final piping inspection.** This inspection shall be made after piping authorized by the permit has been installed and after all portions thereof which are to be covered or concealed are so concealed and after fixtures, appliances or shutoff valves have been attached thereto.

**G2417.1.2 Repairs and additions.** In the event repairs or additions are made after the pressure test, the affected piping shall be tested.

Minor repairs and additions are not required to be pressure tested provided that the work is inspected and connections are tested with a noncorrosive leak-detecting fluid or other approved leak-detecting methods.

**G2417.1.3 New branches.** Where new branches are installed from the point of delivery to new appliances, only the newly installed branches shall be required to be pressure tested. Connections between the new piping and the existing piping shall be tested with a noncorrosive leak-detecting fluid or other approved leak-detecting methods.

**G2417.1.4 Section testing.** A piping system shall be permitted to be tested as a complete unit or in sections. Under no circumstances shall a valve in a line be used as a bulkhead between gas in one section of the piping system and test medium in an adjacent section, unless two valves are installed in series with a valved "tell-tale" located between these valves. A valve shall not be subjected to the test pressure unless it can be determined that the valve, including the valve closing mechanism, is designed to safely withstand the test pressure.

**G2417.1.5 Regulators and valve assemblies.** Regulator and valve assemblies fabricated independently of the piping system in which they are to be installed shall be permitted to be tested with inert gas or air at the time of fabrication.

**G2417.2 Test medium.** The test medium shall be air, nitrogen, carbon dioxide or an inert gas. Oxygen shall not be used.

**G2417.3 Test preparation.** Pipe joints, including welds, shall be left exposed for examination during the test.

**Exception:** Covered or concealed pipe end joints that have been previously tested in accordance with this code.

**G2417.3.1 Expansion joints.** Expansion joints shall be provided with temporary restraints, if required, for the additional thrust load under test.

**G2417.3.2 Equipment isolation.** Equipment that is not to be included in the test shall be either disconnected from the piping or isolated by blanks, blind flanges or caps.

**G2417.3.3 Equipment disconnection.** Where the piping system is connected to equipment or components designed for operating pressures of less than the test pressure, such equipment or equipment components shall be isolated from the piping system by disconnecting them and capping the outlet(s).

**G2417.3.4 Valve isolation.** Where the piping system is connected to equipment or components designed for operating pressures equal to or greater than the test pressure, such equipment shall be isolated from the piping system by closing the individual equipment shutoff valve(s).

**G2417.3.5 Testing precautions.** All testing of piping systems shall be done with due regard for the safety of employees and the public during the test. Prior to testing, the interior of the pipe shall be cleared of all foreign material.

**G2417.4 Test pressure measurement.** Test pressure shall be measured with a manometer or with a pressure-measuring device designed and calibrated to read, record, or indicate a pressure loss caused by leakage during the pressure test period. The source of pressure shall be isolated before the pressure tests are made. Mechanical gauges used to measure test pressures shall have a range such that the highest end of the scale is not greater than five times the test pressure.

**G2417.4.1 Test pressure.** Gas piping systems under 14 inches (3.5 kPa) water column pressure shall be tested at a pressure of not less than 10 pounds per square inch (69 kPa) gage. Test pressures shall be held for not less than 15 minutes with no perceptible drop in pressure. For welded piping, and for piping carrying gas at pressures exceeding 14 inches water column (3484 Pa) pressure, the test pressure shall be at least 60 pounds per square inch (0.0422 kg/mm<sup>2</sup>) for not less than 30 minutes.

**Exception:** Testing, inspection and purging of gas piping systems performed by using NFPA 54 shall be permitted.

## SECTION G2418 PIPING SUPPORT

**G2418.1 General.** Fuel-gas piping shall be provided with support in accordance with Section G2418.2.

**G2418.2 Design and installation.** Piping shall be supported with pipe hooks, metal pipe straps, bands, brackets or hangers suitable for the size of piping, of adequate strength and quality, and located at intervals so as to prevent or damp out excessive vibration. Piping shall be anchored to prevent undue strains on connected equipment and shall not be supported by other piping. Pipe hangers and supports shall conform to the requirements of MSS SP-58 and shall be spaced in accordance with Section G2424. Supports, hangers, and anchors shall be installed so as not to interfere with the free expansion and contraction of the piping between anchors. All parts of the supporting equipment shall be designed and installed so they will not be disengaged by movement of the supported piping.

## SECTION G2419 SEDIMENT TRAPS

**G2419.1 Sediment trap.** Where a sediment trap is not incorporated as part of the gas utilization equipment, a sediment trap shall be installed downstream of the equipment shutoff valve as close to the inlet of the equipment as practical. The sediment trap shall be either a tee fitting with a capped nipple in the bottom opening of the run of the tee or other device approved as an effective sediment trap. Illuminating appliances, ranges, clothes dryers and outdoor grills need not be so equipped.

FUEL GAS

**SECTION G2420  
GAS SHUTOFF VALVES**

**G2420.1 General.** Piping systems shall be provided with shutoff valves in accordance with this section.

**G2420.1.1 Valve approval.** Shutoff valves shall be of an approved type. Shutoff valves shall be constructed of materials compatible with the gas piping. Shutoff valves installed in a portion of a piping system operating above 0.5 psig shall comply with ASME B16.33. Shutoff valves installed in a portion of a piping system operating at 0.5 psig or less shall comply with ANSI Z21.15 or ASME B16.33.

**G2420.1.2 Prohibited locations.** Shutoff valves shall be prohibited in concealed locations and furnace plenums.

**G2420.1.3 Access to shutoff valves.** Shutoff valves shall be located in places so as to provide access for operation and shall be installed so as to be protected from damage.

**G2420.2 Meter valve.** Every meter shall be equipped with a shutoff valve located on the supply side of the meter.

**G2420.3 Individual buildings.** In a common system serving more than one building, shutoff valves shall be installed outdoors at each building.

**G2420.4 Line pressure regulator valves.** A listed shutoff valve shall be installed immediately ahead of each line pressure regulator.

**G2420.5 Equipment shutoff valve.** Each appliance shall be provided with a shutoff valve separate from the appliance. The shutoff valve shall be located in the same room as the appliance, not further than 6 feet (1829 mm) from the appliance, and shall be installed upstream from the union, connector or quick disconnect device it serves. Such shutoff valves shall be provided with access.

**Exception:** Shutoff valves for vented decorative appliances and decorative appliances for installation in vented fireplaces shall not be prohibited from being installed in an area remote from the appliance where such valves are provided with access. Such valves shall be permanently identified and shall serve no other equipment.

**G2420.5.1 Shutoff valve in fireplace.** Equipment shutoff valves located in the firebox of a fireplace shall be installed in accordance with the appliance manufacturer's instructions.

**SECTION G2421  
FLOW CONTROLS**

**G2421.1 Pressure regulators.** A line pressure regulator shall be installed where the appliance is designed to operate at a lower pressure than the supply system. Access shall be provided to pressure regulators. Pressure regulators shall be protected from physical damage. Regulators installed on the exterior of the building shall be approved for outdoor installation.

**G2421.2 Line pressure regulators.** Line pressure regulators shall comply with the following:

1. The line pressure regulator shall comply with ANSI Z21.80 and shall be suitable for the inlet and outlet gas pressures for the application.

2. The line pressure regulator shall maintain a reduced outlet pressure under lockup (no-flow) conditions.

3. The capacity of the line pressure regulator, determined by published ratings of its manufacturer, shall be adequate to supply the appliances served.

4. The line pressure regulator shall be provided with access. Where located indoors, the regulator shall be vented to the outdoors or shall be equipped with a leak-limiting device, in either case complying with Section G2421.3.

5. A tee fitting with one opening capped or plugged shall be installed between the line pressure regulator and its upstream shutoff valve. Such tee fitting shall be positioned to allow connection of a pressure measuring instrument and to serve as a sediment trap.

6. A tee fitting with one opening capped or plugged shall be installed not less than 10 pipe diameters downstream of the line pressure regulator outlet. Such tee fitting shall be positioned to allow connection of a pressure measuring instrument.

**G2421.3 Venting of regulators.** Pressure regulators that require a vent shall have an independent vent to the outside of the building. The vent shall be designed to prevent the entry of water or foreign objects.

**Exception:** A vent to the outside of the building is not required for regulators equipped with and labeled for utilization with approved vent-limiting devices installed in accordance with the manufacturer's instructions. Leak limiting devices shall comply with ANSI Z21.80.

**SECTION G2422  
APPLIANCE CONNECTIONS**

**G2422.1 Connecting appliances.** Appliances shall be connected to the piping system by one of the following:

1. Rigid metallic pipe and fittings.
2. Listed and labeled appliance connectors installed in accordance with the manufacturer's installation instructions and located entirely in the same room as the appliance.
3. Listed and labeled quick-disconnect devices used in conjunction with listed and labeled appliance connectors.
4. Listed and labeled gas convenience outlets used in conjunction with listed and labeled appliance connectors.

**G2422.1.1 Protection from damage.** Connectors and tubing shall be installed so as to be protected against physical damage.

**G2422.1.2 Appliance fuel connectors.** Connectors shall have an overall length not to exceed 3 feet (914 mm), except for range and domestic clothes dryer connectors, which shall not exceed 6 feet (1829 mm) in length. Connectors shall not be concealed within, or extended through, walls, floors, partitions, ceilings or appliance housings. A shutoff valve not less than the nominal size of the connector shall be installed ahead of the connector in accordance with Section

G2420.5. Connectors shall be sized to provide the total demand of the connected appliance.

**Exception:** Fireplace inserts factory equipped with grommets, sleeves or other means of protection in accordance with the listing of the appliance.

**G2422.1.3 Movable appliances.** Where appliances are equipped with casters or are otherwise subject to periodic movement or relocation for purposes such as routine cleaning and maintenance, such appliances shall be connected to the supply system piping by means of an approved flexible connector designed and labeled for the application. Such flexible connectors shall be installed and protected against physical damage in accordance with the manufacturer's installation instructions.

### SECTION G2423 CNG GAS-DISPENSING SYSTEMS

**G2423.1 General.** Service stations for CNG fuel shall be in accordance the *Fire Code*.

### SECTION G2424 PIPING SUPPORT INTERVALS

**G2424.1 Interval of support.** Fuel-gas piping shall be supported at intervals not exceeding the spacing specified in Table G2424.1. Spacing of supports for CSST shall be in accordance with the CSST manufacturer's instructions.

TABLE G2424.1  
SUPPORT OF PIPING

STEEL PIPE, NOMINAL SIZE OF PIPE (inches)	SPACING OF SUPPORTS (feet)	NOMINAL SIZE OF TUBING SMOOTH-WALL (inch O.D.)	SPACING OF SUPPORTS (feet)
1/2	6	1/2	4
3/4 or 1	8	5/8 or 3/4	6
1 1/4 or larger (horizontal)	10	7/8 or 1 (horizontal)	8
1 1/4 or larger (vertical)	Every floor level	1 or Larger (vertical)	Every floor level

For SI: 1 inch = 25.4 mm, 1 foot = 304.8 mm.

### SECTION G2425 GENERAL

> **G2425.1 Scope.** This section shall govern the installation, repair and approval of factory-built and masonry chimneys, chimney liners, vents and connectors serving gas-fired appliances.

**G2425.2 General.** Every appliance shall discharge the products of combustion to the outdoors, except for appliances exempted by Section G2425.8.

> **G2425.3 Masonry chimneys.** Masonry chimneys shall be constructed in accordance with Chapter 10.

**G2425.4 Minimum size of chimney or vent.** Chimneys and vents shall be sized in accordance with Section G2427.

**G2425.5 Abandoned inlet openings.** Abandoned inlet openings in chimneys and vents shall be closed by an approved method.

**G2425.6 Positive pressure.** Where an appliance equipped with a mechanical forced draft system creates a positive pressure in the venting system, the venting system shall be designed for positive pressure applications.

**G2425.7 Connection to fireplace.** Connection of appliances to chimney flues serving fireplaces shall be in accordance with Sections G2425.7.1 through G2425.7.3.

**G2425.7.1 Closure and access.** A noncombustible seal shall be provided below the point of connection to prevent entry of room air into the flue. Means shall be provided for access to the flue for inspection and cleaning.

**G2425.7.2 Connection to factory-built fireplace flue.** An appliance shall not be connected to a flue serving a factory-built fireplace unless the appliance is specifically listed for such installation. The connection shall be made in accordance with the appliance manufacturer's installation instructions.

**G2425.7.3 Connection to masonry fireplace flue.** A connector shall extend from the appliance to the flue serving a masonry fireplace such that the flue gases are exhausted directly into the flue. The connector shall be accessible or removable for inspection and cleaning of both the connector and the flue. Listed direct connection devices shall be installed in accordance with their listing.

**G2425.8 Equipment not required to be vented.** The following appliances shall not be required to be vented:

1. Ranges.
2. Built-in domestic cooking units listed and marked for optional venting.
3. Hot plates and laundry stoves.
4. Type 1 clothes dryers (Type 1 clothes dryers shall be exhausted in accordance with the requirements of Section G2439).
5. Refrigerators.
6. Counter appliances.
7. Room heaters listed for unvented use.

Where the appliances and equipment listed in Items 5 through 7 above are installed so that the aggregate input rating exceeds 20 Btu per hour per cubic foot (207 watts per m<sup>3</sup>) of volume of the room or space in which such appliances and equipment are installed, one or more shall be provided with venting systems or other approved means for conveying the vent gases to the outdoor atmosphere so that the aggregate input rating of the remaining unvented appliances and equipment does not exceed the 20 Btu per hour per cubic foot (207 watts per m<sup>3</sup>) figure. Where the room or space in which the equipment is installed is directly connected to another room or space by a doorway, archway or other opening of comparable size that cannot be closed, the

## FUEL GAS

volume of such adjacent room or space shall be permitted to be included in the calculations.

**G2425.9 Chimney entrance.** Connectors shall connect to a masonry chimney flue at a point not less than 12 inches (305 mm) above the lowest portion of the interior of the chimney flue.

**G2425.10 Connections to exhauster.** Appliance connections to a chimney or vent equipped with a power exhauster shall be made on the inlet side of the exhauster. Joints on the positive pressure side of the exhauster shall be sealed to prevent flue-gas leakage as specified by the manufacturer's installation instructions for the exhauster.

> **G2425.11 Masonry chimneys.** Masonry chimneys utilized to vent appliances shall be sized as specified in the manufacturer's installation instructions for the appliances being vented and Section G2427.

**G2425.12 Residential and low-heat appliances flue lining systems.** Flue lining systems for use with residential-type and low-heat appliances shall be limited to the following:

1. Clay flue lining complying with the requirements of ASTM C 315 or equivalent. Clay flue lining shall be installed in accordance with Chapter 10.
2. Listed chimney lining systems complying with UL 1777.
3. Other approved materials that will resist, without cracking, softening or corrosion, flue gases and condensate at temperatures up to 1,800°F (982°C).

**G2425.13 Category I appliance flue lining systems.** Flue lining systems for use with Category I appliances shall be limited to the following:

1. Flue lining systems complying with Section G2425.12.
2. Chimney lining systems listed and labeled for use with appliances with draft hoods and other Category I gas appliances listed and labeled for use with Type B vents.

**G2425.14 Category II, III and IV appliance venting systems.** The design, sizing and installation of vents for Category II, III and IV appliances shall be in accordance with the appliance manufacturer's installation instructions.

**G2425.15 Existing chimneys and vents.** Where an appliance is permanently disconnected from an existing chimney or vent, or where an appliance is connected to an existing chimney or vent during the process of a new installation, the chimney or vent shall comply with Sections G2425.15.1 through G2425.15.4.

**G2425.15.1 Size.** The chimney or vent shall be resized as necessary to control flue gas condensation in the interior of the chimney or vent and to provide the appliance or appliances served with the required draft. For Category I appliances, the resizing shall be in accordance with Section G2426.

**G2425.15.2 Flue passageways.** The flue gas passageway shall be free of obstructions and combustible deposits and shall be cleaned if previously used for venting a solid or liquid fuel-burning appliance or fireplace. The flue liner, chimney inner wall or vent inner wall shall be continuous and shall be free of cracks, gaps, perforations, or other damage or deterioration that would allow the escape of combustion products, including gases, moisture and creosote.

**G2425.15.3 Cleanout.** Masonry chimney flues shall be provided with a cleanout opening having a minimum height of 6 inches (152 mm). The upper edge of the opening shall be located not less than 6 inches (152 mm) below the lowest chimney inlet opening. The cleanout shall be provided with a tight-fitting, noncombustible cover.

**G2425.15.4 Clearances.** Chimneys and vents shall have air-space clearance to combustibles in accordance with Chapter 10 and the chimney or vent manufacturer's installation instructions. Noncombustible firestopping or fireblocking shall be provided in accordance with Chapter 10.

**Exception:** Masonry chimneys equipped with a chimney lining system tested and listed for installation in chimneys in contact with combustibles in accordance with UL 1777, and installed in accordance with the manufacturer's instructions, shall not be required to have clearance between combustible materials and exterior surfaces of the masonry chimney.

## SECTION G2426 VENTS

**G2426.1 General.** All vents, except as provided in Section G2427.7, shall be listed and labeled. Type B and BW vents shall be tested in accordance with UL 441. Type L vents shall be tested in accordance with UL 641. Vents for Category II and III appliances shall be tested in accordance with UL 1738. Plastic vents for Category IV appliances shall not be required to be listed and labeled where such vents are as specified by the appliance manufacturer and are installed in accordance with the appliance manufacturer's installation instructions.

**G2426.2 Connectors required.** Connectors shall be used to connect appliances to the vertical chimney or vent, except where the chimney or vent is attached directly to the appliance. Vent connector size, material, construction and installation shall be in accordance with Section G2427.

**G2426.3 Vent application.** The application of vents shall be in accordance with Table G2427.4.

**G2426.4 Insulation shield.** Where vents pass through insulated assemblies, an insulation shield constructed of not less than 26 gage sheet (0.016 inch) (0.4 mm) metal shall be installed to provide clearance between the vent and the insulation material. The clearance shall not be less than the clearance to combustibles specified by the vent manufacturer's installation instructions. Where vents pass through attic space, the shield shall terminate not less than 2 inches (51 mm) above the insulation materials and shall be secured in place to prevent displacement. Insulation shields provided as part of a listed vent system shall be installed in accordance with the manufacturer's installation instructions.

**G2426.5 Installation.** Vent systems shall be sized, installed and terminated in accordance with the vent and appliance manufacturer's installation instructions and Section G2427.

**G2426.6 Support of vents.** All portions of vents shall be adequately supported for the design and weight of the materials employed.

**SECTION G2427  
 VENTING OF EQUIPMENT**

**G2427.1 General.** This section recognizes that the choice of venting materials and the methods of installation of venting systems are dependent on the operating characteristics of the equipment being vented. The operating characteristics of vented equipment can be categorized with respect to (1) positive or negative pressure within the venting system; and (2) whether or not the equipment generates flue or vent gases that might condense in the venting system. See Section G2403 for the definition of these vented appliance categories.

**G2427.2 Venting systems required.** Except as permitted in Section G2427.2.1, Section G2427.2.2 and Section G2425.8, all equipment shall be connected to venting systems.

**G2427.2.1 Direct-vent equipment.** Listed direct-vent equipment shall be considered properly vented where installed in accordance with the terms of its listing, the manufacturer's instructions and Section G2427.8, Item 3.

**G2427.2.2 Equipment with integral vents.** Equipment incorporating integral venting means shall be considered properly vented when installed in accordance with its listing, the manufacturer's instructions and Section G2427.8, Items 1 and 2.

**G2427.3 Design and construction.** A venting system shall be designed and constructed so as to develop a positive flow adequate to remove flue or vent gases to the outdoor atmosphere.

**G2427.3.1 Equipment draft requirements.** A venting system shall satisfy the draft requirements of the equipment in accordance with the manufacturer's instructions.

**G2427.3.2 Design and construction.** Gas utilization equipment required to be vented shall be connected to a venting system designed and installed in accordance with the provisions of Sections G2427.4 through G2427.15.

**G2427.3.3 Mechanical draft systems.** Mechanical draft systems shall comply with the following:

1. Mechanical draft systems shall be listed and shall be installed in accordance with the terms of their listing and both the appliance and the mechanical draft system manufacturer's instructions.
2. Equipment, except incinerators, requiring venting shall be permitted to be vented by means of mechanical draft systems of either forced or induced draft design.
3. Forced draft systems and all portions of induced draft systems under positive pressure during operation shall be designed and installed so as to prevent leakage of flue or vent gases into a building.
4. Vent connectors serving equipment vented by natural draft shall not be connected into any portion of mechanical draft systems operating under positive pressure.
5. When a mechanical draft system is employed, provision shall be made to prevent the flow of gas to the main burners when the draft system is not performing so as to satisfy the operating requirements of the equipment for safe performance.
6. The exit terminals of mechanical draft systems shall be not less than 7 feet (2134 mm) above grade where located adjacent to public walkways and shall be located as specified in Section G2427.8, Items 1 and 2.

**G2427.3.4 Circulating air ducts and furnace plenums.** No portion of a venting system shall extend into or pass through any circulating air duct or furnace plenum.

**G2427.4 Type of venting system to be used.** The type of venting system to be used shall be in accordance with Table G2427.4.

**TABLE G2427.4  
 TYPE OF VENTING SYSTEM TO BE USED**

GAS UTILIZATION EQUIPMENT	TYPE OF VENTING SYSTEM
Listed Category I equipment Listed equipment equipped with draft hood Equipment listed for use with Type B gas vent	Type B gas vent (G2427.6) Chimney (G2427.5) Single-wall metal pipe (G2427.7) Listed chimney lining system for gas venting (G2427.5.2). Special gas vent listed for this equipment (G2427.4.2)
Listed vented wall furnaces	Type B-W gas vent (G2427.6, G2436)
Category II equipment	As specified or furnished by manufacturers of listed equipment (G2427.4.1, G2427.4.2)
Category III equipment	As specified or furnished by manufacturers of listed equipment (G2427.4.1, G2427.4.2)
Category IV equipment	As specified or furnished by manufacturers of listed equipment (G2427.4.1, G2427.4.2)
Unlisted equipment	Chimney (see G2427.5)
Decorative appliance in vented fireplace	Chimney
Direct-vent equipment	See G2427.2.1
Equipment with integral vent	See G2427.2.2

## FUEL GAS

**G2427.4.1 Plastic piping.** Plastic piping used for venting equipment listed for use with such venting materials shall be approved.

**G2427.4.2 Special gas vent.** Special gas vents shall be listed and installed in accordance with the terms of the special gas vent listing and the manufacturers' instructions.

**G2427.5 Masonry, metal, and factory-built chimneys.** Masonry, metal and factory-built chimneys shall comply with Sections G2427.5.1 through G2427.5.9.

**G2427.5.1 Factory-built chimneys.** Factory-built chimneys shall be installed in accordance with their listing and the manufacturers' instructions. Factory-built chimneys used to vent appliances that operate at positive vent pressure shall be listed for such application.

**G2427.5.2 Masonry chimneys.** Masonry chimneys shall be built and installed in accordance with Chapter 10 and shall be lined with approved clay flue lining, a listed chimney lining system, or other approved material that will resist corrosion, erosion, softening or cracking from vent gases at temperatures up to 1,800°F (982°C).

**Exception:** Masonry chimney flues serving listed gas appliances with draft hoods, Category I appliances, and other gas appliances listed for use with Type B vent shall be permitted to be lined with a chimney lining system specifically listed for use only with such appliances. The liner shall be installed in accordance with the liner manufacturer's instructions and the terms of the listing. A permanent identifying label shall be attached at the point where the connection is to be made to the liner. The label shall read: "This chimney liner is for appliances that burn gas only. Do not connect to solid or liquid fuel-burning appliances or incinerators."

**G2427.5.3 Chimney termination.** Chimneys shall extend at least 3 feet (914 mm) above the highest point where it passes through a roof of a building and at least 2 feet (610 mm) higher than any portion of a building within a horizontal distance of 10 feet (3048 mm) (see Figure G2427.5.3). Chimneys shall extend at least 5 feet (1524 mm) above the highest connected equipment draft hood outlet or flue collar. Decorative shrouds shall not be installed at the termination of factory-built chimneys except where such shrouds are listed and labeled for use with the specific factory-built chimney system and are installed in accordance with the manufacturers' installation instructions.

**G2427.5.4 Size of chimneys.** The effective area of a chimney venting system serving listed appliances with draft hoods, Category I appliances, and other appliances listed for use with Type B vents shall be determined in accordance with one of the following methods:

1. The provisions of Section G2428.
2. For sizing an individual chimney venting system for a single appliance with a draft hood, the effective areas of the vent connector and chimney flue shall be not less than the area of the appliance flue collar or draft hood outlet, nor greater than seven times the draft hood outlet area.

3. For sizing a chimney venting system connected to two appliances with draft hoods, the effective area of the chimney flue shall be not less than the area of the larger draft hood outlet plus 50 percent of the area of the smaller draft hood outlet, nor greater than seven times the smallest draft hood outlet area.
4. Chimney venting systems using mechanical draft shall be sized in accordance with approved engineering methods.
5. Other approved engineering methods.

**G2427.5.5 Inspection of chimneys.** Before replacing an existing appliance or connecting a vent connector to a chimney, the chimney passageway shall be examined to ascertain that it is clear and free of obstructions and it shall be cleaned if previously used for venting solid or liquid fuel-burning appliances or fireplaces.

**G2427.5.5.1 Chimney lining.** Chimneys shall be lined in accordance with Chapter 10.

**G2427.5.5.2 Cleanouts.** Cleanouts shall be installed in accordance with Chapter 10.

**G2427.5.5.3 Unsafe chimneys.** Where inspection reveals that an existing chimney is not safe for the intended application, it shall be repaired, rebuilt, lined, relined, or replaced with a vent or chimney to conform to M1805 and Chapter 10, and it shall be suitable for the equipment to be vented.

**G2427.5.6 Chimneys serving equipment burning other fuels.** Chimneys serving equipment burning other fuels shall comply with Sections G2427.5.6.1 through G2427.5.6.4.

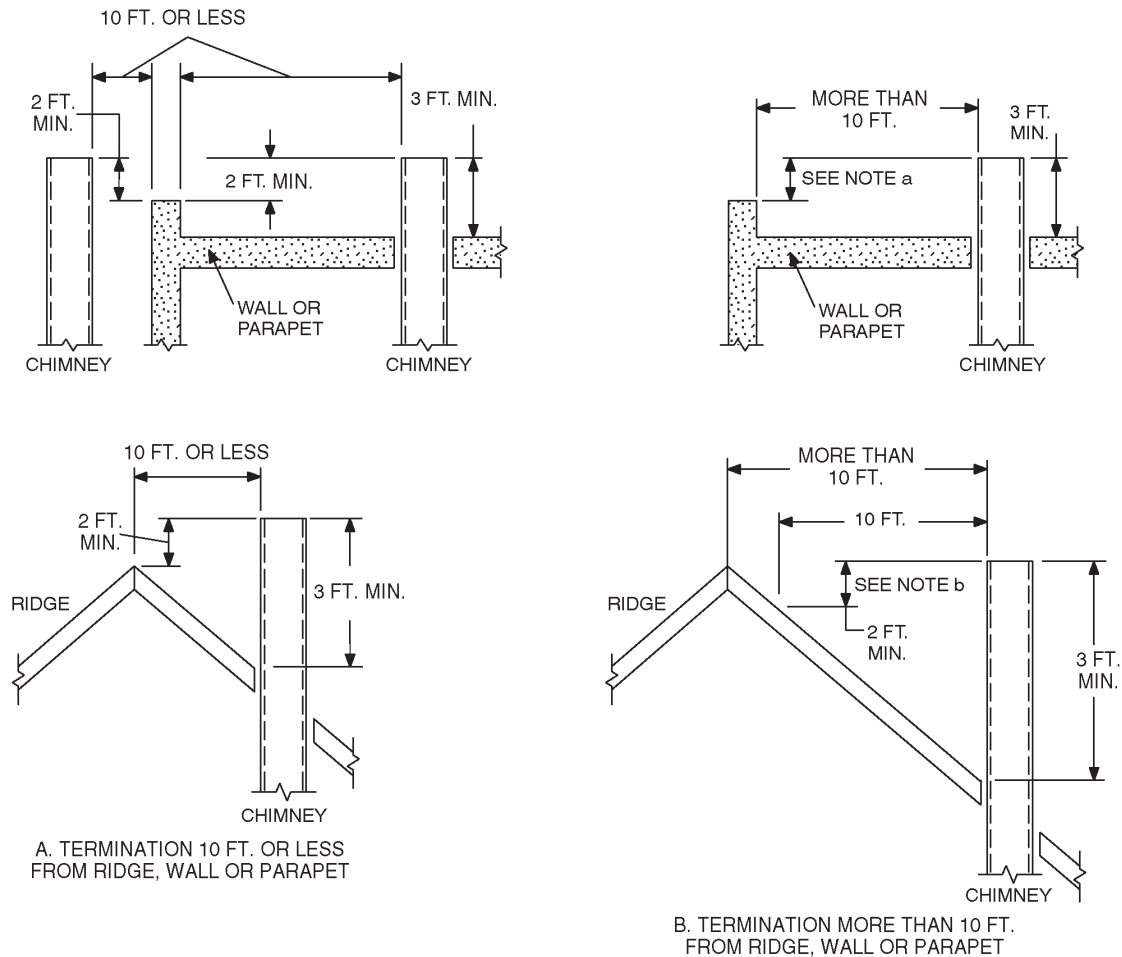
**G2427.5.6.1 Solid fuel-burning appliances.** Gas utilization equipment shall not be connected to a chimney flue serving a separate appliance designed to burn solid fuel.

**G2427.5.6.2 Common venting of gas utilization equipment and liquid fuel-burning appliances.** The common venting of gas utilization equipment and liquid fuel-burning appliances shall comply with Sections M1804.3.2 and M1804.3.2.1.

**G2427.5.6.3 Combination gas- and solid fuel-burning appliances.** A combination gas- and solid fuel-burning appliance equipped with a manual reset device to shut off gas to the main burner in the event of sustained backdraft or flue gas spillage shall be permitted to be connected to a single chimney flue. The chimney flue shall be sized to properly vent the appliance.

**G2427.5.6.4 Combination gas- and oil fuel-burning appliances.** A listed combination gas- and oil fuel-burning appliance shall be permitted to be connected to a single chimney flue. The chimney flue shall be sized to properly vent the appliance.

**G2427.5.7 Support of chimneys.** All portions of chimneys shall be supported for the design and weight of the materials employed. Factory-built chimneys shall be supported and spaced in accordance with their listings and the manufacturer's instructions.



For SI: 1 inch = 25.4 mm, 1 foot = 304.8 mm.

NOTES:

- a. No height above parapet required when distance from walls or parapet is more than 10 feet.
- b. Height above any roof surface within 10 feet horizontally.

**FIGURE G2427.5.3**  
**TYPICAL TERMINATION LOCATIONS FOR CHIMNEYS AND SINGLE-WALL METAL PIPES**

**G2427.5.8 Cleanouts.** Where a chimney that formerly carried flue products from liquid or solid fuel-burning appliances is used with an appliance using fuel gas, an accessible cleanout shall be provided. The cleanout shall have a tight-fitting cover and be installed so its upper edge is at least 6 inches (152 mm) below the lower edge of the lowest chimney inlet opening.

**G2427.5.9 Space surrounding lining or vent.** The remaining space surrounding a chimney liner, gas vent, special gas vent, or plastic piping installed within a masonry chimney flue shall not be used to vent another appliance. The insertion of another liner or vent within the chimney as provided in this code and the liner or vent manufacturer's instructions shall not be prohibited.

The remaining space surrounding a chimney liner, gas vent, special gas vent, or plastic piping installed within a masonry, metal or factory-built chimney, shall not be used to supply combustion air. Such space shall not be prohibited from supplying combustion air to direct-vent appliances de-

signed for installation in a solid fuel-burning fireplace and installed in accordance with the listing and the manufacturer's instructions.

**G2427.6 Gas vents.** Gas vents shall comply with Sections G2427.6.1 through G2427.6.10. (See Section G2403, Definitions.)

**G2427.6.1 Installation, general.** Gas vents shall be installed in accordance with the terms of their listings and the manufacturer's instructions.

**G2427.6.2 Type B-W vent capacity.** A Type B-W gas vent shall have a listed capacity not less than that of the listed vented wall furnace to which it is connected.

**G2427.6.3 Roof penetration.** A gas vent passing through a roof shall extend through the roof flashing, roof jack or roof thimble and shall be terminated by a listed termination cap.

**G2427.6.4 Offsets.** Type B or Type L vents shall extend in a generally vertical direction with offsets not exceeding 45 degrees (0.79 rad), except that a vent system having not

**FUEL GAS**

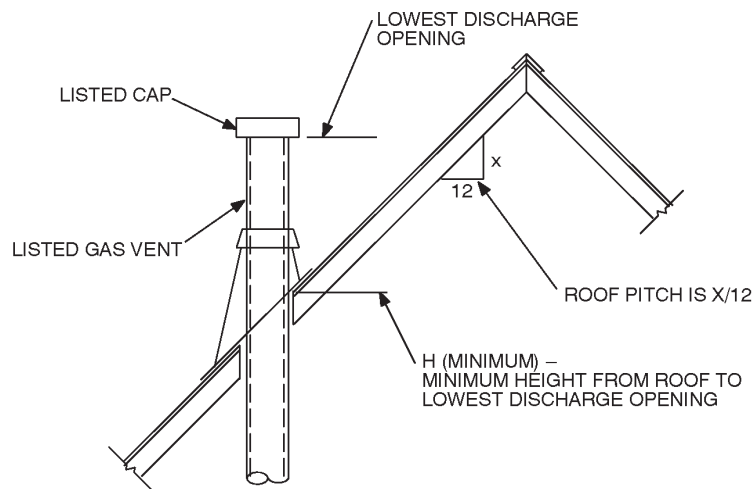
more than one 60-degree offset shall be permitted. Any angle greater than 45 degrees (0.79 rad) from the vertical is considered horizontal. The total horizontal distance of a vent plus the horizontal vent connector serving draft-hood-equipped appliances shall not be greater than 75 percent of the vertical height of the vent.

**Exception:** Systems designed and sized as provided in Section G2428 or in accordance with other approved engineering methods.

Vents serving Category I fan-assisted appliances shall be installed in accordance with the appliance manufacturer's instructions and Section G2428 or other approved engineering methods.

**G2427.6.5 Gas vent termination.** A gas vent shall terminate in accordance with one of the following:

1. Above the roof surface with a listed cap or listed roof assembly. Gas vents 12 inches (305 mm) in size or smaller with listed caps shall be permitted to be terminated in accordance with Figure G2427.6.5, provided that such vents are at least 8 feet (2438 mm) from a vertical wall or similar obstruction. All other gas vents shall terminate not less than 2 feet (610 mm) above the highest point where they pass through the roof and at least 2 feet (610 mm) higher than any portion of a building within 10 feet (3048 mm).
2. As provided for direct-vent systems in Section G2427.2.1.
3. As provided for equipment with integral vents in Section G2427.2.2.
4. As provided for mechanical draft systems in Section G2427.3.3.



ROOF PITCH	H (minimum) ft	m
Flat to $\frac{6}{12}$	1.0	0.30
Over $\frac{6}{12}$ to $\frac{7}{12}$	1.25	0.38
Over $\frac{7}{12}$ to $\frac{8}{12}$	1.5	0.46
Over $\frac{8}{12}$ to $\frac{9}{12}$	2.0	0.61
Over $\frac{9}{12}$ to $\frac{10}{12}$	2.5	0.76
Over $\frac{10}{12}$ to $\frac{11}{12}$	3.25	0.99
Over $\frac{11}{12}$ to $\frac{12}{12}$	4.0	1.22
Over $\frac{12}{12}$ to $\frac{14}{12}$	5.0	1.52
Over $\frac{14}{12}$ to $\frac{16}{12}$	6.0	1.83
Over $\frac{16}{12}$ to $\frac{18}{12}$	7.0	2.13
Over $\frac{18}{12}$ to $\frac{20}{12}$	7.5	2.27
Over $\frac{20}{12}$ to $\frac{21}{12}$	8.0	2.44

For SI: 1 foot = 304.8 mm.

**FIGURE G2427.6.5  
GAS VENT TERMINATION LOCATIONS FOR LISTED CAPS 12 INCHES  
OR LESS IN SIZE AT LEAST 8 FEET FROM A VERTICAL WALL**

**G2427.6.5.1 Decorative shrouds.** Decorative shrouds shall not be installed at the termination of gas vents except where such shrouds are listed for use with the specific gas venting system and are installed in accordance with manufacturer's installation instructions.

**G2427.6.6 Minimum height.** A Type B or Type L gas vent shall terminate at least 5 feet (1524 mm) in vertical height above the highest connected equipment draft hood or flue collar. A Type B-W gas vent shall terminate at least 12 feet (3658 mm) in vertical height above the bottom of the wall furnace.

**G2427.6.7 Exterior wall penetrations.** A gas vent extending through an exterior wall shall not terminate adjacent to the wall or below eaves or parapets, except as provided in Sections G2427.2.1 and G2427.3.3.

**G2427.6.8 Size of gas vents.** Venting systems shall be sized and constructed in accordance with Section G2428 or other approved engineering methods and the gas vent and gas equipment manufacturers' instructions.

**G2427.6.8.1 Category I appliances.** The sizing of natural draft venting systems serving one or more listed appliances equipped with a draft hood or appliances listed for use with Type B gas vent, installed in a single story of a building, shall be in accordance with one of the following methods:

1. The provisions of Section G2428.
2. For sizing an individual gas vent for a single, draft-hood-equipped appliance, the effective area of the vent connector and the gas vent shall be not less than the area of the appliance draft hood outlet, nor greater than seven times the draft hood outlet area.
3. For sizing a gas vent connected to two appliances with draft hoods, the effective area of the vent shall be not less than the area of the larger draft hood outlet plus 50 percent of the area of the smaller draft hood outlet, nor greater than seven times the smaller draft hood outlet area.
4. Approved engineering practices.

**G2427.6.8.2 Category II, III, and IV appliances.** The sizing of gas vents for Category II, III and IV equipment shall be in accordance with the equipment manufacturer's instructions.

**G2427.6.8.3 Mechanical draft.** Chimney venting systems using mechanical draft shall be sized in accordance with approved engineering methods.

**G2427.6.9 Support of gas vents.** Gas vents shall be supported and spaced in accordance with their listings and the manufacturers' instructions.

**G2427.6.10 Marking.** In those localities where solid and liquid fuels are used extensively, gas vents shall be permanently identified by a label attached to the wall or ceiling at a

point where the vent connector enters the gas vent. The determination of where such localities exist shall be made by the code official. The label shall read:

"This gas vent is for appliances that burn gas. Do not connect to solid or liquid fuel-burning appliances or incinerators."

**G2427.7 Single-wall metal pipe.** Single-wall metal pipe vents shall comply with Sections G2427.7.1 through G2427.7.12.

**G2427.7.1 Construction.** Single-wall metal pipe shall be constructed of galvanized sheet steel not less than 0.0304 inch (0.7 mm) thick, or other approved, noncombustible, corrosion-resistant material.

**G2427.7.2 Cold climate.** Uninsulated single-wall metal pipe shall not be used outdoors in cold climates for venting gas utilization equipment.

**G2427.7.3 Termination.** Single-wall metal pipe shall terminate at least 5 feet (1524 mm) in vertical height above the highest connected equipment draft hood outlet or flue collar. Single-wall metal pipe shall extend at least 2 feet (610 mm) above the highest point where it passes through a roof of a building and at least 2 feet (610 mm) higher than any portion of a building within a horizontal distance of 10 feet (3048 mm) (see Figure G2427.5.3). An approved cap or roof assembly shall be attached to the terminus of a single-wall metal pipe. [Also see Section G2427.7.8, Item 3.]

**G2427.7.4 Limitations of use.** Single-wall metal pipe shall be used only for runs directly from the space in which the equipment is located through the roof or exterior wall to the outdoor atmosphere.

**G2427.7.5 Roof penetrations.** A pipe passing through a roof shall extend without interruption through the roof flashing, roof jack or roof thimble. Where a single-wall metal pipe passes through a roof constructed of combustible material, a noncombustible, nonventilating thimble shall be used at the point of passage. The thimble shall extend at least 18 inches (457 mm) above and 6 inches (152 mm) below the roof with the annular space open at the bottom and closed only at the top. The thimble shall be sized in accordance with Section G2427.10.15.

**G2427.7.6 Installation.** Single-wall metal pipe shall not originate in any unoccupied attic or concealed space and shall not pass through any attic, inside wall, concealed space or floor. The installation of a single-wall metal pipe through an exterior combustible wall shall comply with Section G2427.10.15.

**G2427.7.7 Clearances.** Minimum clearances from single-wall metal pipe to combustible material shall be in accordance with Table G2427.7.7. The clearance from single-wall metal pipe to combustible material shall be permitted to be reduced where the combustible material is protected as specified for vent connectors in Table G2409.2.

FUEL GAS

**TABLE G2427.7.7  
CLEARANCES FOR CONNECTORS**

Equipment	MINIMUM DISTANCE FROM COMBUSTIBLE MATERIAL			
	Listed Type B gas vent material	Listed Type L vent material	Single-wall metal pipe	Factory-built chimney sections
Listed equipment with draft hoods and equipment listed for use with Type B Gas Vents	as listed	as listed	6 inches	as listed
Residential boilers and furnaces with listed gas conversion burner and with draft hood	6 inches	6 inches	9 inches	as listed
Residential appliances listed for use with Type L vents	not permitted	as listed	9 inches	as listed
Unlisted residential appliances with draft hood	not permitted	6 inches	9 inches	as listed
Residential and low-heat equipment other than those above	not permitted	9 inches	18 inches	as listed

For SI: 1 inch = 25.4 mm.

NOTE: These clearances shall apply unless the listing of an appliance or connector specifies different clearances, in which case the listed clearances shall apply.

**G2427.7.8 Size of single-wall metal pipe.** A venting system constructed of single-wall metal pipe shall be sized in accordance with one of the following methods and the equipment manufacturer's instructions:

1. For a draft hood-equipped appliance, in accordance with Section G2428.
2. For a venting system for a single appliance with a draft hood, the areas of the connector and the pipe each shall not be less than the area of the appliance flue collar or draft hood outlet, whichever is smaller. The vent area shall not be greater than seven times the draft hood outlet area.
3. Other approved engineering methods.

**G2427.7.9 Pipe geometry.** Any shaped single-wall metal pipe shall be permitted to be used, provided its equivalent effective area is equal to the effective area of the round pipe for which it is substituted and provided the minimum internal dimension of the pipe is not less than 2 inches (51 mm).

**G2427.7.10 Termination capacity.** The vent cap or a roof assembly shall have a venting capacity not less than that of the pipe to which it is attached.

**G2427.7.11 Support of single-wall metal pipe.** All portions of single-wall metal pipe shall be supported for the design and weight of the material employed.

**G2427.7.12 Marking.** Single-wall metal pipe shall comply with the marking provisions of Section G2427.6.10.

**G2427.8 Venting system termination location.** The location of venting system terminations shall comply with the following (see Appendix C):

1. A mechanical draft venting system shall terminate at least 3 feet (914 mm) above any forced-air inlet located within 10 feet (3048 mm).

**Exceptions:**

1. This provision shall not apply to the combustion air intake of a direct-vent appliance.

2. This provision shall not apply to the separation of the integral outdoor air inlet and flue gas discharge of listed outdoor appliances.

2. A mechanical draft venting system, excluding direct-vent appliances, shall terminate at least 4 feet (1219 mm) below, 4 feet (1219 mm) horizontally from, or 1 foot (305 mm) above any door, operable window, or gravity air inlet into any building. The bottom of the vent terminal shall be located at least 12 inches (305 mm) above grade.
3. The vent terminal of a direct-vent appliance with an input of 10,000 Btu per hour (3 kW) or less shall be located at least 6 inches (152 mm) from any air opening into a building, and such an appliance with an input over 10,000 Btu per hour (3 kW) but not over 50,000 Btu per hour (14.7 kW) shall be installed with a 9-inch (230 mm) vent termination clearance, and an appliance with an input over 50,000 Btu/h (14.7 kw) shall have at least a 12-inch (305 mm) vent termination clearance. The bottom of the vent terminal and the air intake shall be located at least 12 inches (305 mm) above grade.
4. Through-the-wall vents for Category II and IV appliances and noncategorized condensing appliances shall not terminate over public walkways or over an area where condensate or vapor could create a nuisance or hazard or could be detrimental to the operation of regulators, relief valves, or other equipment. Where local experience indicates that condensate is a problem with Category I and III appliances, this provision shall also apply.

**G2427.9 Condensation drainage.** Provision shall be made to collect and dispose of condensate from venting systems serving Category II and IV equipment and noncategorized condensing appliances in accordance with Section G2427.8, Item 4. Where local experience indicates that condensation is a problem, provision shall be made to drain off and dispose of condensate from venting systems serving Category I and III equipment in accordance with Section G2427.8, Item 4.

**G2427.10 Vent connectors for Category I gas utilization equipment.** Vent connectors for Category I equipment shall comply with Sections G2427.10.1 through G2427.10.15.

**G2427.10.1 Where required.** A vent connector shall be used to connect equipment to a gas vent, chimney or single-wall metal pipe, except where the gas vent, chimney or single-wall metal pipe is directly connected to the equipment.

**G2427.10.2 Materials.** Vent connectors shall be constructed in accordance with Sections G2427.10.2.1 through G2427.10.2.4.

**G2427.10.2.1 General.** A vent connector shall be made of noncombustible corrosion-resistant material capable of withstanding the vent gas temperature produced by the equipment and of sufficient thickness to withstand physical damage.

**G2427.10.2.2 Vent connectors located in unconditioned areas.** Where the vent connector used for equipment having a draft hood or a Category I appliance is located in or passes through attics, crawl spaces or other unconditioned spaces, that portion of the vent connector shall be listed Type B or Type L or listed vent material or listed material having equivalent insulation properties.

**Exception:** Single-wall metal pipe located within the exterior walls of the building in areas having a local 99-percent winter design temperature of 5°F (-15°C) or higher shall be permitted to be used in unconditioned spaces other than attics, garages, and crawl spaces.

**G2427.10.2.3 Residential-type appliance connectors.** Where vent connectors for residential-type appliances are not installed in attics or other unconditioned spaces, connectors for listed appliances having draft hoods and for appliances having draft hoods and equipped with listed conversion burners shall be one of the following:

1. Type B or Type L vent material;
2. Galvanized sheet steel not less than 0.018 inch (0.46 mm) thick;
3. Aluminum (1100 or 3003 alloy or equivalent) sheet not less than 0.027 inch (0.69 mm) thick;
4. Stainless steel sheet not less than 0.012 inch (0.31 mm) thick;
5. Smooth interior wall metal pipe having resistance to heat and corrosion equal to or greater than that of Item 2, 3 or 4 above; or
6. A listed vent connector.

**G2427.10.2.4 Low-heat equipment.** A vent connector for low-heat equipment shall be a factory-built chimney section or steel pipe having resistance to heat and corrosion equivalent to that for the appropriate galvanized pipe as specified in Table G2427.10.2.4. Factory-built chimney sections shall be joined together in accordance with the chimney manufacturers' instructions.

**TABLE G2427.10.2.4  
MINIMUM THICKNESS FOR GALVANIZED STEEL VENT  
CONNECTORS FOR LOW-HEAT APPLIANCES**

DIAMETER OF CONNECTOR (inches)	MINIMUM THICKNESS (inch)
Less than 6	0.019
6 to less than 10	0.023
10 to 12 inclusive	0.029
14 to 16 inclusive	0.034
Over 16	0.056

For SI: 1 inch = 25.4 mm, 1 square inch = 645.16 mm<sup>2</sup>.

**G2427.10.3 Size of vent connector.** Vent connectors shall be sized in accordance with Sections G2427.10.3.1 through G2427.10.3.5.

**G2427.10.3.1 Single draft hood and fan assisted.** A vent connector for equipment with a single draft hood or for a Category I fan-assisted combustion system appliance shall be sized and installed in accordance with Section G2428 or other approved engineering methods.

**G2427.10.3.2 Multiple draft hood.** For a single appliance having more than one draft hood outlet or flue collar, the manifold shall be constructed according to the instructions of the appliance manufacturer. If there are no instructions, the manifold shall be designed and constructed in accordance with approved engineering practices. As an alternate method, the effective area of the manifold shall equal the combined area of the flue collars or draft hood outlets and the vent connectors shall have a minimum 1 foot (305 mm) rise.

**G2427.10.3.3 Multiple appliances.** Where two or more appliances are connected to a common vent or chimney, each vent connector shall be sized in accordance with Section G2428 or other approved engineering methods.

As an alternative method applicable only where all of the appliances are draft hood equipped, each vent connector shall have an effective area not less than the area of the draft hood outlet of the appliance to which it is connected.

**G2427.10.3.4 Common connector/manifold.** Where two or more gas appliances are vented through a common vent connector or vent manifold, the common vent connector or vent manifold shall be located at the highest level consistent with available headroom and the required clearance to combustible materials and shall be sized in accordance with Section G2428 or other approved engineering methods.

As an alternate method applicable only where there are two draft-hood-equipped appliances, the effective area of the common vent connector or vent manifold and all junction fittings shall be not less than the area of the larger vent connector plus 50 percent of the area of the smaller flue collar outlet.

## FUEL GAS

**G2427.10.3.5 Size increase.** Where the size of a vent connector is increased to overcome installation limitations and obtain connector capacity equal to the equipment input, the size increase shall be made at the equipment draft hood outlet.

**G2427.10.4 Two or more appliances connected to a single vent.** Where two or more vent connectors enter a common gas vent, chimney flue or single-wall metal pipe, the smaller connector shall enter at the highest level consistent with the available headroom or clearance to combustible material. Vent connectors serving Category I appliances shall not be connected to any portion of a mechanical draft system operating under positive static pressure, such as those serving Category III or IV appliances.

**G2427.10.5 Clearance.** Minimum clearances from vent connectors to combustible material shall be in accordance with Table G2427.7.7.

**Exception:** The clearance between a vent connector and combustible material shall be permitted to be reduced where the combustible material is protected as specified for vent connectors in Table G2409.2.

**G2427.10.6 Flow resistance.** A vent connector shall be installed so as to avoid turns or other construction features that create excessive resistance to flow of vent gases.

**G2427.10.7 Joints.** Joints between sections of connector piping and connections to flue collars and hood outlets shall be fastened by one of the following methods:

1. Sheet metal screws.
2. Vent connectors of listed vent material assembled and connected to flue collars or draft hood outlets in accordance with the manufacturers' instructions.
3. Other approved means.

**G2427.10.8 Slope.** A vent connector shall be installed without dips or sags and shall slope upward toward the vent or chimney at least  $\frac{1}{4}$  inch per foot (21 mm/m).

**Exception:** Vent connectors attached to a mechanical draft system installed in accordance with the manufacturer's instructions.

**G2427.10.9 Length of vent connector.** A vent connector shall be as short as practical and the equipment located as close as practical to the chimney or vent. Except as provided for in Section G2427.10.3, the maximum horizontal length of a single-wall connector shall be 75 percent of the height of the chimney or vent. Except as provided for in Section G2427.10.3, the maximum horizontal length of a Type B double-wall connector shall be 100 percent of the height of the chimney or vent. For a chimney or vent system serving multiple appliances, the maximum length of an individual connector, from the appliance outlet to the junction with the common vent or another connector, shall be 100 percent of the height of the chimney or vent.

**G2427.10.10 Support.** A vent connector shall be supported for the design and weight of the material employed to maintain clearances and prevent physical damage and separation of joints.

**G2427.10.11 Chimney connection.** Where entering a flue in a masonry or metal chimney, the vent connector shall be installed above the extreme bottom to avoid stoppage. A thimble or slip joint shall be permitted to be used to facilitate removal of the connector. The connector shall be firmly attached to or inserted into the thimble or slip joint to prevent the connector from falling out. Means shall be employed to prevent the connector from entering so far as to restrict the space between its end and the opposite wall of the chimney flue. (See Section G2425.9.)

**G2427.10.12 Inspection.** The entire length of a vent connector shall be provided with ready access for inspection, cleaning and replacement.

**G2427.10.13 Fireplaces.** A vent connector shall not be connected to a chimney flue serving a fireplace unless the fireplace flue opening is permanently sealed.

**G2427.10.14 Passage through ceilings, floors or walls.** A vent connector shall not pass through any ceiling, floor or fire-resistance-rated wall. A single-wall metal pipe connector shall not pass through any interior wall.

**Exception:** Vent connectors made of listed Type B or Type L vent material and serving listed equipment with draft hoods and other equipment listed for use with Type B gas vents shall be permitted to pass through walls or partitions constructed of combustible material if the connectors are installed with not less than the listed clearance to combustible material.

**G2427.10.15 Single-wall connector penetrations of combustible walls.** A vent connector made of a single-wall metal pipe shall not pass through a combustible exterior wall unless guarded at the point of passage by a ventilated metal thimble not smaller than the following:

1. For listed appliances equipped with draft hoods and appliances listed for use with Type B gas vents, the thimble shall be not less than 4 inches (102 mm) larger in diameter than the vent connector. Where there is a run of not less than 6 feet (1829 mm) of vent connector in the open between the draft hood outlet and the thimble, the thimble shall be permitted to be 2 inches (51 mm) larger in diameter than the vent connector.
2. For unlisted appliances having draft hoods, the thimble shall be not less than 6 inches (152 mm) larger in diameter than the vent connector.
3. For residential appliances and low-heat appliances, the thimble shall be not less than 12 inches (305 mm) larger in diameter than the vent connector.

**Exception:** In lieu of thimble protection, all combustible material in the wall shall be removed from the vent connector a sufficient distance to provide the specified clearance from such vent connector to combustible material. Any material used to close up such opening shall be noncombustible.

**G2427.11 Vent connectors for Category II, III and IV appliances.** Vent connectors for Category II, III and IV appliances shall be as specified for the venting system in accordance with Section G2427.4.

**G2427.12 Draft hoods and draft controls.** The installation of draft hoods and draft controls shall comply with Sections G2427.12.1 through G2427.12.7.

**G2427.12.1 Equipment requiring draft hoods.** Vented equipment shall be installed with draft hoods.

**Exception:** Dual-oven type combination ranges; incinerators; direct-vent equipment; fan-assisted combustion system appliances; equipment requiring chimney draft for operation; single firebox boilers equipped with conversion burners with inputs greater than 400,000 Btu per hour (117 kw); equipment equipped with blast, power or pressure burners that are not listed for use with draft hoods; and equipment designed for forced venting.

**G2427.12.2 Installation.** A draft hood supplied with or forming a part of listed vented equipment shall be installed without alteration, exactly as furnished and specified by the equipment manufacturer.

**G2427.12.2.1 Draft hood required.** If a draft hood is not supplied by the equipment manufacturer where one is required, a draft hood shall be installed, shall be of a listed or approved type and, in the absence of other instructions, shall be of the same size as the equipment flue collar. Where a draft hood is required with a conversion burner, it shall be of a listed or approved type.

**G2427.12.2.2 Special design draft hood.** Where it is determined that a draft hood of special design is needed or preferable for a particular installation, the installation shall be in accordance with the recommendations of the equipment manufacturer and shall be approved.

**G2427.12.3 Draft control devices.** Where a draft control device is part of the equipment or is supplied by the equipment manufacturer, it shall be installed in accordance with the manufacturer's instructions. In the absence of manufacturers' instructions, the device shall be attached to the flue collar of the equipment or as near to the equipment as practical.

**G2427.12.4 Additional devices.** Equipment requiring controlled chimney draft shall be permitted to be equipped with a listed double acting barometric draft regulator installed and adjusted in accordance with the manufacturer's instructions.

**G2427.12.5 Location.** Draft hoods and draft regulators shall be installed in the same room or enclosure as the equipment in such a manner as to prevent any difference in pressure between the hood or regulator and the combustion air supply.

**G2427.12.6 Positioning.** Draft hoods and draft regulators shall be installed in the position for which they were designed with reference to the horizontal and vertical planes and shall be located so that the relief opening is not obstructed by any part of the equipment or adjacent construction. The equipment and its draft hood shall be located so that the relief opening is accessible for checking vent operation.

**G2427.12.7 Clearance.** A draft hood shall be located so its relief opening is not less than 6 inches (152 mm) from any surface except that of the equipment it serves and the vent-

ing system to which the draft hood is connected. Where a greater or lesser clearance is indicated on the equipment label, the clearance shall be not less than that specified on the label. Such clearances shall not be reduced.

**G2427.13 Manually operated dampers.** A manually operated damper shall not be placed in the vent connector for any equipment. Fixed baffles shall not be classified as manually operated dampers.

**G2427.14 (503.14) Automatically operated vent dampers.** An automatically operated vent damper shall be of a listed type.

**G2427.15 Obstructions.** Devices that retard the flow of vent gases shall not be installed in a vent connector, chimney, or vent. The following shall not be considered as obstructions:

1. Draft regulators and safety controls specifically listed for installation in venting systems and installed in accordance with the terms of their listing.
2. Approved draft regulators and safety controls that are designed and installed in accordance with approved engineering methods.
3. Listed heat reclaimers and automatically operated vent dampers installed in accordance with the terms of their listing.
4. Approved economizers, heat reclaimers, and recuperators installed in venting systems of equipment not required to be equipped with draft hoods, provided that the gas utilization equipment manufacturer's instructions cover the installation of such a device in the venting system and performance in accordance with Sections G2427.3 and G2427.3.1 is obtained.
5. Vent dampers serving listed appliances installed in accordance with Sections G2428.2.1 and G2428.3.1 or other approved engineering methods.

## SECTION G2428 SIZING OF CATEGORY I APPLIANCE VENTING SYSTEMS

*(Note: Although not specifically adopted, see Appendix B for examples of Category I appliance venting.)*

**G2428.1 Definitions.** The following definitions apply to tables in this section.

**APPLIANCE CATEGORIZED VENT DIAMETER/AREA.** The minimum vent area/diameter permissible for Category I appliances to maintain a nonpositive vent static pressure when tested in accordance with nationally recognized standards.

**FAN-ASSISTED COMBUSTION SYSTEM.** An appliance equipped with an integral mechanical means to either draw or force products of combustion through the combustion chamber or heat exchanger.

**FAN MIN.** The minimum input rating of a Category I fan-assisted appliance attached to a vent or connector.

**FAN MAX.** The maximum input rating of a Category I fan-assisted appliance attached to a vent or connector.

## FUEL GAS

**NAT MAX.** The maximum input rating of a Category I draft-hood-equipped appliance attached to a vent or connector.

**FAN + FAN.** The maximum combined appliance input rating of two or more Category I fan-assisted appliances attached to the common vent.

**FAN + NAT.** The maximum combined appliance input rating of one or more Category I fan-assisted appliances and one or more Category I draft-hood-equipped appliances attached to the common vent.

**NA.** Vent configuration is not permitted due to potential for condensate formation or pressurization of the venting system, or not applicable due to physical or geometric restraints.

**NAT + NAT.** The maximum combined appliance input rating of two or more Category I draft-hood-equipped appliances attached to the common vent.

**G2428.2 Application of single appliance vent Tables G2428.2(1) and G2428.2(2).** The application of Tables G2428.2(1) and G2428.2(2) shall be subject to the requirements of Sections G2428.2.1 through G2428.2.15.

**G2428.2.1 Vent obstructions.** These venting tables shall not be used where obstructions, as described in Section G2427.15, are installed in the venting system. The installation of vents serving listed appliances with vent dampers shall be in accordance with the appliance manufacturer's instructions or in accordance with the following:

1. The maximum capacity of the vent system shall be determined using the "NAT Max" column.
2. The minimum capacity shall be determined as if the appliance were a fan-assisted appliance, using the "FAN Min" column to determine the minimum capacity of the vent system. Where the corresponding "FAN Min" is "NA," the vent configuration shall not be permitted and an alternative venting configuration shall be utilized.

**G2428.2.2 Minimum size.** Where the vent size determined from the tables is smaller than the appliance draft hood outlet or flue collar, the smaller size shall be permitted to be used provided all of the following are met:

1. The total vent height (H) is at least 10 feet (3048 mm).
2. Vents for appliance draft hood outlets or flue collars 12 inches (305 mm) in diameter or smaller are not reduced more than one table size.
3. Vents for appliance draft hood outlets or flue collars larger than 12 inches (305 mm) in diameter are not reduced more than two table sizes.
4. The maximum capacity listed in the tables for a fan-assisted appliance is reduced by 10 percent (0.90 by maximum table capacity).
5. The draft hood outlet is greater than 4 inches (102 mm) in diameter. Do not connect a 3-inch-diameter (76 mm) vent to a 4-inch-diameter (102 mm) draft hood outlet. This provision shall not apply to fan-assisted appliances.

**G2428.2.3 Vent offsets.** Single-appliance venting configurations with zero (0) lateral lengths in Tables G2428.2(1) and G2428.2(2) shall not have elbows in the venting system. For vent configurations with lateral lengths, the venting tables include allowance for two 90-degree (1.57 rad) turns. For each elbow up to and including 45 degrees (0.79 rad), the maximum capacity listed in the venting tables shall be reduced by 5 percent. For each elbow greater than 45 degrees (0.79 rad) up to and including 90 degrees (1.57 rad), the maximum capacity listed in the venting tables shall be reduced by 10 percent.

**G2428.2.4 Zero lateral.** Zero (0) lateral (L) shall apply only to a straight vertical vent attached to a top outlet draft hood or flue collar.

**G2428.2.5 High altitude installations.** Sea level input ratings shall be used when determining maximum capacity for high altitude installation. Actual input, derated for altitude, shall be used for determining minimum capacity for high altitude installation.

**G2428.2.6 Multiple input rate appliances.** For appliances with more than one input rate, the minimum vent capacity (FAN Min) determined from the tables shall be less than the lowest appliance input rating, and the maximum vent capacity (FAN Max/NAT Max) determined from the tables shall be greater than the highest appliance rating input.

**G2428.2.7 Liner system sizing.** Listed corrugated metallic chimney liner systems in masonry chimneys shall be sized by using Table G2428.2(1) or G2428.2(2) for Type B vents with the maximum capacity reduced by 20 percent (0.80 × maximum capacity) and the minimum capacity as shown in Table G2428.2(1) or G2428.2(2). Corrugated metallic liner systems installed with bends or offsets shall have their maximum capacity further reduced in accordance with Section G2428.2.3. The 20-percent reduction for corrugated metallic chimney liner systems includes an allowance for one long-radius 90-degree (1.57 rad) turn at the bottom of the liner.

**G2428.2.8 Vent area and diameter.** Where the vertical vent has a larger diameter than the vent connector, the vertical vent diameter shall be used to determine the minimum vent capacity, and the connector diameter shall be used to determine the maximum vent capacity. The flow area of the vertical vent shall not exceed seven times the flow area of the listed appliance categorized vent area, flue collar area, or draft hood outlet area unless designed in accordance with approved engineering methods.

**G2428.2.9 Chimney and vent locations.** Tables G2428.2(1) and G2428.2(2) shall be used for chimneys and vents not exposed to the outdoors below the roof line. A Type B vent or listed chimney lining system passing through an unused masonry chimney flue shall not be considered to be exposed to the outdoors.

**Exception:** The installation of vents serving listed appliances shall be permitted to be in accordance with the appliance manufacturer's instructions and the terms of the listing.

**G2428.2.10 Corrugated vent connector size.** Corrugated vent connectors shall be not smaller than the listed appliance categorized vent diameter, flue collar diameter, or draft hood outlet diameter.

**G2428.2.11 Vent connector size limitation.** Vent connectors shall not be increased in size more than two sizes greater than the listed appliance categorized vent diameter, flue collar diameter or draft hood outlet diameter.

**G2428.2.12 Component commingling.** In a single run of vent or vent connector, different diameters and types of vent and connector components shall be permitted to be used, provided that all such sizes and types are permitted by the tables.

**G2428.2.13 Table interpolation.** Interpolation shall be permitted in calculating capacities for vent dimensions that fall between the table entries. (See Example 3, Appendix B.)

**G2428.2.14 Extrapolation prohibited.** Extrapolation beyond the table entries shall not be permitted.

**G2428.2.15 Engineering calculations.** For vent heights less than 6 feet (1829 mm) and greater than shown in the tables, engineering methods shall be used to calculate vent capacities.

**G2428.3 Application of multiple appliance vent Tables G2428.3(1) through G2428.3(4).** The application of Tables G2428.3(1) through G2428.3(4) shall be subject to the requirements of Sections G2428.3.1 through G2428.3.22.

**G2428.3.1 Vent obstructions.** These venting tables shall not be used where obstructions, as described in Section G2427.15, are installed in the venting system. The installation of vents serving listed appliances with vent dampers shall be in accordance with the appliance manufacturer's instructions or in accordance with the following:

1. The maximum capacity of the vent connector shall be determined using the NAT Max column.
2. The maximum capacity of the vertical vent or chimney shall be determined using the FAN+NAT column when the second appliance is a fan-assisted appliance, or the NAT+NAT column when the second appliance is equipped with a draft hood.
3. The minimum capacity shall be determined as if the appliance were a fan-assisted appliance.
  - 3.1. The minimum capacity of the vent connector shall be determined using the FAN Min column.
  - 3.2. The FAN+FAN column shall be used when the second appliance is a fan-assisted appliance, and the FAN+NAT column shall be used when the second appliance is equipped with a draft hood, to determine whether the vertical vent or chimney configuration is not permitted (NA). Where the vent configuration is NA, the vent configuration shall not be permitted and an alternative venting configuration shall be utilized.

**G2428.3.2 Connector length limit.** The vent connector shall be routed to the vent utilizing the shortest possible route. Except as provided in Section G2428.3.3, the maximum vent connector horizontal length shall be 1.5 feet (457

mm) for each inch (18 mm per mm) of connector diameter as shown in Table G2428.3.2.

**TABLE G2428.3.2  
MAXIMUM VENT CONNECTOR LENGTH**

CONNECTOR DIAMETER	CONNECTOR HORIZONTAL
Maximum (inches)	Length (feet)
3	4.5
4	6
5	7.5
6	9
7	10.5
8	12
9	13.5

For SI: 1 inch = 25.4 mm, 1 foot = 304.8 mm.

**G2428.3.3 Connectors with longer lengths.** Connectors with longer horizontal lengths than those listed in Section G2428.3.2 are permitted under the following conditions:

1. The maximum capacity (FAN Max or NAT Max) of the vent connector shall be reduced 10 percent for each additional multiple of the length listed above. For example, the maximum length listed above for a 4-inch (102 mm) connector is 6 feet (1829 mm). With a connector length greater than 6 feet (1829 mm), but not exceeding 12 feet (3658 mm), the maximum capacity must be reduced by 10 percent (0.90 × maximum vent connector capacity). With a connector length greater than 12 feet (3658 mm), but not exceeding 18 feet (5486 mm), the maximum capacity must be reduced by 20 percent (0.80 × maximum vent capacity).
2. For a connector serving a fan-assisted appliance, the minimum capacity (FAN Min) of the connector shall be determined by referring to the corresponding single appliance table. For Type B double-wall connectors, Table G2428.2(1) shall be used. For single-wall connectors, Table G2428.2(2) shall be used. The height (H) and lateral (L) shall be measured according to the procedures for a single appliance vent, as if the other appliances were not present.

**G2428.3.4 Vent connector manifold.** Where the vent connectors are combined prior to entering the vertical portion of the common vent to form a common vent manifold, the size of the common vent manifold and the common vent shall be determined by applying a 10-percent reduction (0.90 × maximum common vent capacity) to the common vent capacity part of the common vent tables. The length of the common vent connector manifold ( $L_M$ ) shall not exceed 1½ feet for each inch (457 mm per mm) of common vent connector manifold diameter (D) (see Appendix B Figure B-11).

**G2428.3.5 Common vertical vent offset.** Where the common vertical vent is offset, the maximum capacity of the common vent shall be reduced in accordance with Section G2428.3.6. The horizontal length of the common vent offset ( $L_o$ ) shall not exceed 1½ feet for each inch (457 mm per mm) of common vent diameter.

FUEL GAS

Number of Appliances	Single
Appliance Type	Category I
Appliance Vent Connection	Connected directly to vent

TABLE G2428.2(1)  
TYPE B DOUBLE-WALL GAS VENT

HEIGHT (H) (feet)	LATERAL (L) (feet)	VENT DIAMETER—(D) inches																				
		3			4			5			6			7			8			9		
		FAN		NAT	FAN		NAT	FAN		NAT	FAN		NAT	FAN		NAT	FAN		NAT	FAN		NAT
Min		Max	Min	Max	Min	Max	Min	Max	Min	Max	Min	Max	Min	Max	Min	Max	Min	Max	Min	Max	Min	Max
APPLIANCE INPUT RATING IN THOUSANDS OF BTU/H																						
6	0	0	78	46	0	152	86	0	251	141	0	375	205	0	524	285	0	698	370	0	897	470
	2	13	51	36	18	97	67	27	157	105	32	232	157	44	321	217	53	425	285	63	543	370
	4	21	49	34	30	94	64	39	153	103	50	227	153	66	316	211	79	419	279	93	536	362
8	0	0	84	50	0	165	94	0	276	155	0	415	235	0	583	320	0	780	415	0	1,006	537
	2	12	57	40	16	109	75	25	178	120	28	263	180	42	365	247	50	483	322	60	619	418
	5	23	53	38	32	103	71	42	171	115	53	255	173	70	356	237	83	473	313	99	607	407
10	0	0	88	53	0	175	100	0	295	166	0	447	255	0	631	345	0	847	450	0	1,096	585
	2	12	61	42	17	118	81	23	194	129	26	289	195	40	402	273	48	533	355	57	684	457
	5	23	57	40	32	113	77	41	187	124	52	280	188	68	392	263	81	522	346	95	671	446
15	0	0	94	58	0	191	112	0	327	187	0	502	285	0	716	390	0	970	525	0	1,263	682
	2	11	69	48	15	136	93	20	226	150	22	339	225	38	475	316	45	633	414	53	815	544
	5	22	65	45	30	130	87	39	219	142	49	330	217	64	463	300	76	620	403	90	800	529
20	0	0	97	61	0	202	119	0	349	202	0	540	307	0	776	430	0	1,057	575	0	1,384	752
	2	10	75	51	14	149	100	18	250	166	20	377	249	33	531	346	41	711	470	50	917	612
	5	21	71	48	29	143	96	38	242	160	47	367	241	62	519	337	73	697	460	86	902	599
20	10	28	64	44	38	133	89	50	229	150	62	351	228	81	499	321	95	675	443	112	877	576
	15	34	58	40	46	124	84	59	217	142	73	337	217	94	481	308	111	654	427	129	853	557
	20	48	52	35	55	116	78	69	206	134	84	322	206	107	464	295	125	634	410	145	830	537

(continued)

Number of Appliances	Single
Appliance Type	Category I
Appliance Vent Connection	Connected directly to vent

TABLE G2428.2(1)—continued  
TYPE B DOUBLE-WALL GAS VENT

HEIGHT (H) (feet)	LATERAL (L) (feet)	VENT DIAMETER—(D) inches																					
		3			4			5			6			7			8			9			
		FAN		NAT	FAN		NAT	FAN		NAT	FAN		NAT	FAN		NAT	FAN		NAT	FAN		NAT	
Min		Max	Min	Max	Min	Max	Min	Max	Min	Max	Min	Max	Min	Max	Min	Max	Min	Max	Min	Max	Min	Max	
30	0	0	100	64	0	213	128	0	374	220	0	587	336	0	853	475	0	1,173	650	0	1,548	855	
	2	9	81	56	13	166	112	14	283	185	18	432	280	27	613	394	33	826	535	42	1,072	700	
	5	21	77	54	28	160	108	36	275	176	45	421	273	58	600	385	69	811	524	82	1,055	688	
	10	27	70	50	37	150	102	48	262	171	59	405	261	77	580	371	91	788	507	107	1,028	668	
	15	33	64	NA	NA	44	141	96	57	249	163	70	389	249	90	560	357	105	765	490	124	1,002	648
	20	56	58	NA	NA	53	132	90	66	237	154	80	374	237	102	542	343	119	743	473	139	977	628
50	30	NA	NA	NA	73	113	NA	88	214	NA	104	346	219	131	507	321	149	702	444	171	929	594	
	0	0	101	67	0	216	134	0	397	232	0	633	363	0	932	518	0	1,297	708	0	1,730	952	
	2	8	86	61	11	183	122	14	320	206	15	497	314	22	715	445	26	975	615	33	1,276	813	
	5	20	82	NA	27	177	119	35	312	200	43	487	308	55	702	438	65	960	605	77	1,259	798	
	10	26	76	NA	35	168	114	45	299	190	56	471	298	73	681	426	86	935	589	101	1,230	773	
	15	59	70	NA	42	158	NA	54	287	180	66	455	288	85	662	413	100	911	572	117	1,203	747	
20	NA	NA	NA	50	149	NA	63	275	169	76	440	278	97	642	401	113	888	556	131	1,176	722		
30	NA	NA	NA	69	131	NA	84	250	NA	99	410	259	123	605	376	141	844	522	161	1,125	670		

For SI: 1 inch = 25.4 mm, 1 foot = 304.8 mm, 1 British thermal unit per hour = 0.2931 W.

FUEL GAS

Number of Appliances	Single
Appliance Type	Category I
Appliance Vent Connection	Single-wall metal connector

TABLE G2428.2(2)  
TYPE B DOUBLE-WALL GAS VENT

HEIGHT (H) (feet)	LATERAL (L) (feet)	VENT DIAMETER—(D) inches																											
		3			4			5			6			7			8			9			10			12			
		FAN		NAT	FAN		NAT	FAN		NAT	FAN		NAT	FAN		NAT	FAN		NAT	FAN		NAT	FAN		NAT	FAN		NAT	
		Min	Max	Min	Max	Min	Max	Min	Max	Min	Max	Min	Max	Min	Max	Min	Max	Min	Max	Min	Max	Min	Max	Min	Max	Min	Max	Min	Max
6	0	38	77	45	151	85	85	249	140	126	373	204	165	522	284	211	695	369	267	894	469	371	1,118	569	537	1,639	849		
	2	39	51	36	96	66	85	156	104	123	231	156	159	320	213	201	423	284	251	541	368	347	673	453	498	979	648		
	4	NA	NA	33	74	92	102	152	102	146	225	152	187	313	208	237	416	277	295	533	360	409	664	443	584	971	638		
	6	NA	NA	31	83	89	114	147	99	163	220	148	207	307	203	263	409	271	327	526	352	449	656	433	638	962	627		
8	0	37	83	50	58	164	93	83	273	154	412	234	161	580	319	206	777	414	258	1,002	536	360	1,257	658	521	1,852	967		
	2	39	56	39	59	108	75	83	176	119	121	179	155	363	246	197	482	321	246	617	417	339	768	513	486	1,120	743		
	5	NA	NA	37	77	102	69	107	168	114	151	171	193	352	235	245	470	311	305	604	404	418	754	500	598	1,104	730		
	8	NA	NA	33	90	95	64	122	161	107	175	163	223	342	225	280	458	300	344	591	392	470	740	486	665	1,089	715		
10	0	37	87	53	57	174	99	82	293	165	444	254	158	628	344	202	844	449	253	1,093	584	351	1,373	718	507	2,031	1,057		
	2	39	61	41	59	117	80	82	193	128	119	187	194	400	272	193	531	354	242	681	456	332	849	559	475	1,242	848		
	5	52	56	39	76	111	76	105	185	122	148	186	190	388	261	241	518	344	299	667	443	409	834	544	584	1,224	825		
	10	NA	NA	34	97	100	68	132	171	112	188	171	237	369	241	296	497	325	363	643	423	492	808	520	688	1,194	788		
15	0	36	93	57	56	190	111	80	325	186	499	283	153	713	388	195	966	523	244	1,259	681	336	1,591	838	488	2,374	1,237		
	2	38	69	47	57	136	93	80	225	149	115	337	224	448	314	187	631	413	232	812	543	319	1,015	673	457	1,491	983		
	5	51	63	44	75	128	86	102	216	140	144	326	217	459	298	231	616	400	287	795	526	392	997	657	562	1,469	963		
	10	NA	NA	39	95	116	79	128	201	131	182	308	203	438	284	284	592	381	349	768	501	470	966	628	664	1,433	928		
	15	NA	NA	NA	NA	NA	72	158	186	124	220	290	192	418	269	334	568	367	404	742	484	540	937	601	750	1,399	894		
20	0	35	96	60	54	200	118	78	346	201	114	537	306	772	428	190	1,053	573	238	1,379	750	326	1,751	927	473	2,631	1,346		
	2	37	74	50	56	148	99	78	248	165	113	375	248	444	344	182	708	468	227	914	611	309	1,146	754	443	1,689	1,098		
	5	50	68	47	73	140	94	100	239	158	141	363	239	491	316	224	692	457	279	896	596	381	1,126	734	547	1,665	1,074		
	10	NA	NA	41	93	129	86	125	223	146	177	344	224	491	316	277	666	437	339	866	570	457	1,092	702	646	1,626	1,037		
	15	NA	NA	NA	NA	NA	80	155	208	136	216	325	210	264	301	325	640	419	393	838	549	526	1,060	677	730	1,587	1,005		
	20	NA	NA	NA	NA	NA	NA	186	192	126	254	306	196	309	448	285	374	400	448	810	526	592	1,028	651	808	1,550	973		

(continued)

Number of Appliances	Single
Appliance Type	Category I
Appliance Vent Connection	Single-wall metal connector

TABLE G2428.2(2)—continued]  
TYPE B DOUBLE-WALL GAS VENT

HEIGHT (H) (feet)	LATERAL (L) (feet)	VENT DIAMETER—(D) inches																										
		3		4		5		6		7		8		9		10		12										
		FAN Min	FAN Max	NAT Min	NAT Max	FAN Min	FAN Max	NAT Min	NAT Max	FAN Min	FAN Max	NAT Min	NAT Max	FAN Min	FAN Max	NAT Min	NAT Max	FAN Min	FAN Max	NAT Min	NAT Max							
30	0	34	99	63	127	76	372	219	110	584	334	144	849	472	184	1,168	647	229	1,542	852	312	1,971	1,056	454	2,996	1,545		
	2	37	80	56	164	111	281	183	109	429	279	139	610	392	175	823	533	219	1,069	698	296	1,346	863	424	1,999	1,308		
	5	49	74	52	157	106	98	271	173	136	417	271	171	595	382	215	806	521	269	1,049	684	366	1,324	846	524	1,971	1,283	
	10	NA	NA	NA	91	144	98	122	255	168	171	397	257	213	570	367	265	777	501	327	1,017	662	440	1,287	821	620	1,927	1,234
	15	NA	NA	NA	115	131	NA	151	239	157	208	377	242	255	547	349	312	750	481	379	985	638	507	1,251	794	702	1,884	1,205
	20	NA	NA	NA	NA	NA	NA	181	223	NA	246	357	228	298	524	333	360	723	461	433	955	615	570	1,216	768	780	1,841	1,166
50	30	NA	NA	NA	NA	NA	NA	NA	NA	NA	NA	389	477	305	461	670	426	541	895	574	704	1,147	720	937	1,759	1,101		
	0	33	99	66	133	73	394	230	105	629	361	138	928	515	176	1,292	704	220	1,724	948	295	2,223	1,189	428	3,432	1,818		
	2	36	84	61	121	73	318	205	104	495	312	133	712	443	168	971	613	209	1,273	811	280	1,615	1,007	401	2,426	1,509		
	5	48	80	NA	117	94	308	198	131	482	305	164	696	435	204	953	602	257	1,252	795	347	1,591	991	496	2,396	1,490		
	10	NA	NA	NA	NA	118	292	186	162	461	292	203	671	420	253	923	583	313	1,217	765	418	1,551	963	589	2,347	1,455		
	15	NA	NA	NA	NA	145	275	174	199	441	280	244	646	405	299	894	562	363	1,183	736	481	1,512	934	668	2,299	1,421		
30	20	NA	NA	NA	NA	176	257	NA	236	420	267	285	622	389	345	866	543	415	1,150	708	544	1,473	906	741	2,251	1,387		
	30	NA	NA	NA	NA	NA	NA	NA	315	376	NA	373	573	NA	442	809	502	521	1,086	649	674	1,399	848	892	2,159	1,318		

For SI: 1 inch = 25.4 mm, 1 foot = 304.8 mm, 1 British thermal unit per hour = 0.2931 W.

FUEL GAS

**TABLE G2428.3(1)**  
**TYPE B DOUBLE-WALL VENT**

<b>Number of Appliances</b>	Two or more
<b>Appliance Type</b>	Category I
<b>Appliance Vent Connection</b>	Type B double-wall connector

**VENT CONNECTOR CAPACITY**

VENT HEIGHT (H) (feet)	CONNECTOR RISE (R) (feet)	TYPE B DOUBLE-WALL VENT AND CONNECTOR DIAMETER—(D) inches																							
		3		4			5			6			7			8			9			10			
		APPLIANCE INPUT RATING LIMITS IN THOUSANDS OF BTU/H																							
		FAN		NAT	FAN		NAT	FAN		NAT	FAN		NAT	FAN		NAT	FAN		NAT	FAN		NAT	FAN		NAT
Min	Max	Max	Min	Max	Max	Min	Max	Max	Min	Max	Max	Min	Max	Max	Min	Max	Max	Min	Max	Max	Min	Max	Max		
6	1	22	37	26	35	66	46	46	106	72	58	164	104	77	225	142	92	296	185	109	376	237	128	466	289
	2	23	41	31	37	75	55	48	121	86	60	183	124	79	253	168	95	333	220	112	424	282	131	526	345
	3	24	44	35	38	81	62	49	132	96	62	199	139	82	275	189	97	363	248	114	463	317	134	575	386
8	1	22	40	27	35	72	48	49	114	76	64	176	109	84	243	148	100	320	194	118	408	248	138	507	303
	2	23	44	32	36	80	57	51	128	90	66	195	129	86	269	175	103	356	230	121	454	294	141	564	358
	3	24	47	36	37	87	64	53	139	101	67	210	145	88	290	198	105	384	258	123	492	330	143	612	402
10	1	22	43	28	34	78	50	49	123	78	65	189	113	89	257	154	106	341	200	125	436	257	146	542	314
	2	23	47	33	36	86	59	51	136	93	67	206	134	91	282	182	109	374	238	128	479	305	149	596	372
	3	24	50	37	37	92	67	52	146	104	69	220	150	94	303	205	111	402	268	131	515	342	152	642	417
15	1	21	50	30	33	89	53	47	142	83	64	220	120	88	298	163	110	389	214	134	493	273	162	609	333
	2	22	53	35	35	96	63	49	153	99	66	235	142	91	320	193	112	419	253	137	532	323	165	658	394
	3	24	55	40	36	102	71	51	163	111	68	248	160	93	339	218	115	445	286	140	565	365	167	700	444
20	1	21	54	31	33	99	56	46	157	87	62	246	125	86	334	171	107	436	224	131	552	285	158	681	347
	2	22	57	37	34	105	66	48	167	104	64	259	149	89	354	202	110	463	265	134	587	339	161	725	414
	3	23	60	42	35	110	74	50	176	116	66	271	168	91	371	228	113	486	300	137	618	383	164	764	466
30	1	20	62	33	31	113	59	45	181	93	60	288	134	83	391	182	103	512	238	125	649	305	151	802	372
	2	21	64	39	33	118	70	47	190	110	62	299	158	85	408	215	105	535	282	129	679	360	155	840	439
	3	22	66	44	34	123	79	48	198	124	64	309	178	88	423	242	108	555	317	132	706	405	158	874	494
50	1	19	71	36	30	133	64	43	216	101	57	349	145	78	477	197	97	627	257	120	797	330	144	984	403
	2	21	73	43	32	137	76	45	223	119	59	358	172	81	490	234	100	645	306	123	820	392	148	1,014	478
	3	22	75	48	33	141	86	46	229	134	61	366	194	83	502	263	103	661	343	126	842	441	151	1,043	538

**COMMON VENT CAPACITY**

VENT HEIGHT (H) (feet)	TYPE B DOUBLE-WALL COMMON VENT DIAMETER (D)—inches																				
	4			5			6			7			8			9			10		
	COMBINED APPLIANCE INPUT RATING IN THOUSANDS OF BTU/H																				
	FAN +FAN	FAN +NAT	NAT +NAT	FAN +FAN	FAN +NAT	NAT +NAT	FAN +FAN	FAN +NAT	NAT +NAT	FAN +FAN	FAN +NAT	NAT +NAT	FAN +FAN	FAN +NAT	NAT +NAT	FAN +FAN	FAN +NAT	NAT +NAT	FAN +FAN	FAN +NAT	NAT +NAT
6	92	81	65	140	116	103	204	161	147	309	248	200	404	314	260	547	434	335	672	520	410
8	101	90	73	155	129	114	224	178	163	339	275	223	444	348	290	602	480	378	740	577	465
10	110	97	79	169	141	124	243	194	178	367	299	242	477	377	315	649	522	405	800	627	495
15	125	112	91	195	164	144	283	228	206	427	352	280	556	444	365	753	612	465	924	733	565
20	136	123	102	215	183	160	314	255	229	475	394	310	621	499	405	842	688	523	1,035	826	640
30	152	138	118	244	210	185	361	297	266	547	459	360	720	585	470	979	808	605	1,209	975	740
50	167	153	134	279	244	214	421	353	310	641	547	423	854	706	550	1,164	977	705	1,451	1,188	860

For SI: 1 inch = 25.4 mm, 1 foot = 304.8 mm, 1 British thermal unit per hour = 0.2931 W.

**TABLE G2428.3(2)  
TYPE B DOUBLE-WALL VENT**

<b>Number of Appliances</b>	Two or more
<b>Appliance Type</b>	Category I
<b>Appliance Vent Connection</b>	Single-wall metal connector

**VENT CONNECTOR CAPACITY**

VENT HEIGHT (H) (feet)	CONNECTOR RISE (R) (feet)	SINGLE-WALL METAL VENT CONNECTOR DIAMETER—(D) inches																									
		3		4		5		6		7		8		9		10											
		APPLIANCE INPUT RATING LIMITS IN THOUSANDS OF BTU/H																									
		FAN		NAT		FAN		NAT		FAN		NAT		FAN		NAT		FAN		NAT		FAN		NAT			
Min	Max	Max	Min	Max	Max	Min	Max	Max	Min	Max	Max	Min	Max	Max	Min	Max	Max	Min	Max	Max	Min	Max	Max				
6	1	NA	NA	26	NA	NA	46	NA	NA	71	NA	NA	102	207	223	140	262	293	183	325	373	234	447	463	286		
	2	NA	NA	31	NA	NA	55	NA	NA	85	168	182	123	215	251	167	271	331	219	334	422	281	458	524	344		
	3	NA	NA	34	NA	NA	62	121	131	95	175	198	138	222	273	188	279	361	247	344	462	316	468	574	385		
8	1	NA	NA	27	NA	NA	48	NA	NA	75	NA	NA	106	226	240	145	285	316	191	352	403	244	481	502	299		
	2	NA	NA	32	NA	NA	57	125	126	89	184	193	127	234	266	173	293	353	228	360	450	292	492	560	355		
	3	NA	NA	35	NA	NA	64	130	138	100	191	208	144	241	287	197	302	381	256	370	489	328	501	609	400		
10	1	NA	NA	28	NA	NA	50	119	121	77	182	186	110	240	253	150	302	335	196	372	429	252	506	534	308		
	2	NA	NA	33	84	85	59	124	134	91	189	203	132	248	278	183	311	369	235	381	473	302	517	589	368		
	3	NA	NA	36	89	91	67	129	144	102	197	217	148	257	299	203	320	398	265	391	511	339	528	637	413		
15	1	NA	NA	29	79	87	52	116	138	81	177	214	116	238	291	158	312	380	208	397	482	266	556	596	324		
	2	NA	NA	34	83	94	62	121	150	97	185	230	138	246	314	189	321	411	248	407	522	317	568	646	387		
	3	NA	NA	39	87	100	70	127	160	109	193	243	157	255	333	215	331	438	281	418	557	360	579	690	437		
20	1	49	56	30	78	97	54	115	152	84	175	238	120	233	325	165	306	425	217	390	538	276	546	664	336		
	2	52	59	36	82	103	64	120	163	101	182	252	144	243	346	197	317	453	259	400	574	331	558	709	403		
	3	55	62	40	87	107	72	125	172	113	190	264	164	252	363	223	326	476	294	412	607	375	570	750	457		
30	1	47	60	31	77	110	57	112	175	89	169	278	129	226	380	175	296	497	230	378	630	294	528	779	358		
	2	51	62	37	81	115	67	117	185	106	177	290	152	236	397	208	307	521	274	389	662	349	541	819	425		
	3	54	64	42	85	119	76	122	193	120	185	300	172	244	412	235	316	542	309	400	690	394	555	855	482		
50	1	46	69	34	75	128	60	109	207	96	162	336	137	217	460	188	284	604	245	364	768	314	507	951	384		
	2	49	71	40	79	132	72	114	215	113	170	345	164	226	473	223	294	623	293	376	793	375	520	983	458		
	3	52	72	45	83	136	82	119	221	123	178	353	186	235	486	252	304	640	331	387	816	423	535	1,013	518		

**COMMON VENT CAPACITY**

VENT HEIGHT (H) (feet)	TYPE B DOUBLE-WALL COMMON VENT DIAMETER— (D) inches																				
	4		5		6		7		8		9		10								
	COMBINED APPLIANCE INPUT RATING IN THOUSANDS OF BTU/H																				
	FAN +FAN	FAN +NAT	NAT +NAT	FAN +FAN	FAN +NAT	NAT +NAT	FAN +FAN	FAN +NAT	NAT +NAT	FAN +FAN	FAN +NAT	NAT +NAT	FAN +FAN	FAN +NAT	NAT +NAT	FAN +FAN	FAN +NAT	NAT +NAT	FAN +FAN	FAN +NAT	NAT +NAT
6	NA	78	64	NA	113	99	200	158	144	304	244	196	398	310	257	541	429	332	665	515	407
8	NA	87	71	NA	126	111	218	173	159	331	269	218	436	342	285	592	473	373	730	569	460
10	NA	94	76	163	137	120	237	189	174	357	292	236	467	369	309	638	512	398	787	617	487
15	121	108	88	189	159	140	275	221	200	416	343	274	544	434	357	738	599	456	905	718	553
20	131	118	98	208	177	156	305	247	223	463	383	302	606	487	395	824	673	512	1,013	808	626
30	145	132	113	236	202	180	350	286	257	533	446	349	703	570	459	958	790	593	1,183	952	723
50	159	145	128	268	233	208	406	337	296	622	529	410	833	686	535	1,139	954	689	1,418	1,157	838

For SI: 1 inch = 25.4 mm, 1 foot = 304.8 mm, 1 British thermal unit per hour = 0.2931 W.

FUEL GAS

TABLE G2428.3(3)  
MASONRY CHIMNEY

Number of Appliances	Two or more
Appliance Type	Category I
Appliance Vent Connection	Type B double-wall connector

VENT CONNECTOR CAPACITY

VENT HEIGHT (H) (feet)	CONNECTOR RISE (R) (feet)	TYPE B DOUBLE-WALL VENT CONNECTOR DIAMETER—(D) inches																							
		3		4			5			6			7			8			9			10			
		APPLIANCE INPUT RATING LIMITS IN THOUSANDS OF BTU/H																							
		FAN		NAT		FAN		NAT		FAN		NAT		FAN		NAT		FAN		NAT		FAN		NAT	
Min	Max	Max	Min	Max	Max	Min	Max	Max	Min	Max	Max	Min	Max	Max	Min	Max	Max	Min	Max	Max	Min	Max	Max		
6	1	24	33	21	39	62	40	52	106	67	65	194	101	87	274	141	104	370	201	124	479	253	145	599	319
	2	26	43	28	41	79	52	53	133	85	67	230	124	89	324	173	107	436	232	127	562	300	148	694	378
	3	27	49	34	42	92	61	55	155	97	69	262	143	91	369	203	109	491	270	129	633	349	151	795	439
8	1	24	39	22	39	72	41	55	117	69	71	213	105	94	304	148	113	414	210	134	539	267	156	682	335
	2	26	47	29	40	87	53	57	140	86	73	246	127	97	350	179	116	473	240	137	615	311	160	776	394
	3	27	52	34	42	97	62	59	159	98	75	269	145	99	383	206	119	517	276	139	672	358	163	848	452
10	1	24	42	22	38	80	42	55	130	71	74	232	108	101	324	153	120	444	216	142	582	277	165	739	348
	2	26	50	29	40	93	54	57	153	87	76	261	129	103	366	184	123	498	247	145	652	321	168	825	407
	3	27	55	35	41	105	63	58	170	100	78	284	148	106	397	209	126	540	281	147	705	366	171	893	463
15	1	24	48	23	38	93	44	54	154	74	72	277	114	100	384	164	125	511	229	153	658	297	184	824	375
	2	25	55	31	39	105	55	56	174	89	74	299	134	103	419	192	128	558	260	156	718	339	187	900	432
	3	26	59	35	41	115	64	57	189	102	76	319	153	105	448	215	131	597	292	159	760	382	190	960	486
20	1	24	52	24	37	102	46	53	172	77	71	313	119	98	437	173	123	584	239	150	752	312	180	943	397
	2	25	58	31	39	114	56	55	190	91	73	335	138	101	467	199	126	625	270	153	805	354	184	1,011	452
	3	26	63	35	40	123	65	57	204	104	75	353	157	104	493	222	129	661	301	156	851	396	187	1,067	505
30	1	24	54	25	37	111	48	52	192	82	69	357	127	96	504	187	119	680	255	145	883	337	175	1,115	432
	2	25	60	32	38	122	58	54	208	95	72	376	145	99	531	209	122	715	287	149	928	378	179	1,171	484
	3	26	64	36	40	131	66	56	221	107	74	392	163	101	554	233	125	746	317	152	968	418	182	1,220	535
50	1	23	51	25	36	116	51	51	209	89	67	405	143	92	582	213	115	798	294	140	1,049	392	168	1,334	506
	2	24	59	32	37	127	61	53	225	102	70	421	161	95	604	235	118	827	326	143	1,085	433	172	1,379	558
	3	26	64	36	39	135	69	55	237	115	72	435	180	98	624	260	121	854	357	147	1,118	474	176	1,421	611

COMMON VENT CAPACITY

VENT HEIGHT (H) (feet)	MINIMUM INTERNAL AREA OF MASONRY CHIMNEY FLUE (square inches)																							
	12		19			28			38			50			63			78			113			
	COMBINED APPLIANCE INPUT RATING IN THOUSANDS OF BTU/H																							
	FAN +FAN	FAN +NAT	NAT +NAT	FAN +FAN	FAN +NAT	NAT +NAT	FAN +FAN	FAN +NAT	NAT +NAT	FAN +FAN	FAN +NAT	NAT +NAT	FAN +FAN	FAN +NAT	NAT +NAT	FAN +FAN	FAN +NAT	NAT +NAT	FAN +FAN	FAN +NAT	NAT +NAT	FAN +FAN	FAN +NAT	NAT +NAT
6	NA	74	25	NA	119	46	NA	178	71	NA	257	103	NA	351	143	NA	458	188	NA	582	246	1,041	853	NA
8	NA	80	28	NA	130	53	NA	193	82	NA	279	119	NA	384	163	NA	501	218	724	636	278	1,144	937	408
10	NA	84	31	NA	138	56	NA	207	90	NA	299	131	NA	409	177	606	538	236	776	686	302	1,226	1,010	454
15	NA	NA	36	NA	152	67	NA	233	106	NA	334	152	523	467	212	682	611	283	874	781	365	1,374	1,156	546
20	NA	NA	41	NA	NA	75	NA	250	122	NA	368	172	565	508	243	742	668	325	955	858	419	1,513	1,286	648
30	NA	NA	NA	NA	NA	NA	NA	270	137	NA	404	198	615	564	278	816	747	381	1,062	969	496	1,702	1,473	749
50	NA	NA	NA	NA	NA	NA	NA	NA	NA	NA	NA	NA	NA	620	328	879	831	461	1,165	1,089	606	1,905	1,692	922

For SI: 1 inch = 25.4 mm, 1 square inch = 645.16 mm<sup>2</sup>, 1 foot = 304.8 mm, 1 British thermal unit per hour = 0.2931 W.

**TABLE G2428.3(4)  
MASONRY CHIMNEY**

<b>Number of Appliances</b>	Two or more
<b>Appliance Type</b>	Category I
<b>Appliance Vent Connection</b>	Single-wall metal connector

**VENT CONNECTOR CAPACITY**

VENT HEIGHT (H) (feet)	CONNECTOR RISE (R) (feet)	SINGLE-WALL METAL VENT CONNECTOR DIAMETER (D)—inches																									
		3			4			5			6			7			8			9			10				
		APPLIANCE INPUT RATING LIMITS IN THOUSANDS OF BTU/H																									
		FAN		NAT		FAN		NAT		FAN		NAT		FAN		NAT		FAN		NAT		FAN		NAT		FAN	
Min	Max	Min	Max	Min	Max	Min	Max	Min	Max	Min	Max	Min	Max	Min	Max	Min	Max	Min	Max	Min	Max	Min	Max	Min	Max	Min	Max
6	1	NA	NA	21	NA	NA	39	NA	NA	66	179	191	100	231	271	140	292	366	200	362	474	252	499	594	316		
	2	NA	NA	28	NA	NA	52	NA	NA	84	186	227	123	239	321	172	301	432	231	373	557	299	509	696	376		
	3	NA	NA	34	NA	NA	61	134	153	97	193	258	142	247	365	202	309	491	269	381	634	348	519	793	437		
8	1	NA	NA	21	NA	NA	40	NA	NA	68	195	208	103	250	298	146	313	407	207	387	530	263	529	672	331		
	2	NA	NA	28	NA	NA	52	137	139	85	202	240	125	258	343	177	323	465	238	397	607	309	540	766	391		
	3	NA	NA	34	NA	NA	62	143	156	98	210	264	145	266	376	205	332	509	274	407	663	356	551	838	450		
10	1	NA	NA	22	NA	NA	41	130	151	70	202	225	106	267	316	151	333	434	213	410	571	273	558	727	343		
	2	NA	NA	29	NA	NA	53	136	150	86	210	255	128	276	358	181	343	489	244	420	640	317	569	813	403		
	3	NA	NA	34	97	102	62	143	166	99	217	277	147	284	389	207	352	530	279	430	694	363	580	880	459		
15	1	NA	NA	23	NA	NA	43	129	151	73	199	271	112	268	376	161	349	502	225	445	646	291	623	808	366		
	2	NA	NA	30	92	103	54	135	170	88	207	295	132	277	411	189	359	548	256	456	706	334	634	884	424		
	3	NA	NA	34	96	112	63	141	185	101	215	315	151	286	439	213	368	586	289	466	755	378	646	945	479		
20	1	NA	NA	23	87	99	45	128	167	76	197	303	117	265	425	169	345	569	235	439	734	306	614	921	347		
	2	NA	NA	30	91	111	55	134	185	90	205	325	136	274	455	195	355	610	266	450	787	348	627	986	443		
	3	NA	NA	35	96	119	64	140	199	103	213	343	154	282	481	219	365	644	298	461	831	391	639	1,042	496		
30	1	NA	NA	24	86	108	47	126	187	80	193	347	124	259	492	183	338	665	250	430	864	330	600	1,089	421		
	2	NA	NA	31	91	119	57	132	203	93	201	366	142	269	518	205	348	699	282	442	908	372	613	1,145	473		
	3	NA	NA	35	95	127	65	138	216	105	209	381	160	277	540	229	358	729	312	452	946	412	626	1,193	524		
50	1	NA	NA	24	85	113	50	124	204	87	188	392	139	252	567	208	328	778	287	417	1,022	383	582	1,302	492		
	2	NA	NA	31	89	123	60	130	218	100	196	408	158	262	588	230	339	806	320	429	1,058	425	596	1,346	545		
	3	NA	NA	35	94	131	68	136	231	112	205	422	176	271	607	255	349	831	351	440	1,090	466	610	1,386	597		

**COMMON VENT CAPACITY**

VENT HEIGHT (H) (feet)	MINIMUM INTERNAL AREA OF MASONRY CHIMNEY FLUE (square inches)																									
	12			19			28			38			50			63			78			113				
	COMBINED APPLIANCE INPUT RATING IN THOUSANDS OF BTU/H																									
	FAN +FAN	FAN +NAT	NAT +NAT	FAN +FAN	FAN +NAT	NAT +NAT	FAN +FAN	FAN +NAT	NAT +NAT	FAN +FAN	FAN +NAT	NAT +NAT	FAN +FAN	FAN +NAT	NAT +NAT	FAN +FAN	FAN +NAT	NAT +NAT	FAN +FAN	FAN +NAT	NAT +NAT	FAN +FAN	FAN +NAT	NAT +NAT	FAN +FAN	FAN +NAT
6	NA	NA	25	NA	118	45	NA	176	71	NA	255	102	NA	348	142	NA	455	187	NA	579	245	NA	846	NA		
8	NA	NA	28	NA	128	52	NA	190	81	NA	276	118	NA	380	162	NA	497	217	NA	633	277	1,136	928	405		
10	NA	NA	31	NA	136	56	NA	205	89	NA	295	129	NA	405	175	NA	532	234	171	680	300	1,216	1,000	450		
15	NA	NA	36	NA	NA	66	NA	230	105	NA	335	150	NA	400	210	677	602	280	866	772	360	1,359	1,139	540		
20	NA	NA	NA	NA	NA	74	NA	247	120	NA	362	170	NA	503	240	765	661	321	947	849	415	1,495	1,264	640		
30	NA	NA	NA	NA	NA	NA	NA	NA	135	NA	398	195	NA	558	275	808	739	377	1,052	957	490	1,682	1,447	740		
50	NA	NA	NA	NA	NA	NA	NA	NA	NA	NA	NA	NA	NA	612	325	NA	821	456	1,152	1,076	600	1,879	1,672	910		

For SI: 1 inch = 25.4 mm, 1 square inch = 645.16 mm<sup>2</sup>, 1 foot = 304.8 mm, 1 British thermal unit per hour = 0.2931 W.

## FUEL GAS

**G2428.3.6 Elbows in vents.** For each elbow up to and including 45 degrees (0.79 rad) in the common vent, the maximum common vent capacity listed in the venting tables shall be reduced by 5 percent. For each elbow greater than 45 degrees (0.79 rad) up to and including 90 degrees (1.57 rad), the maximum common vent capacity listed in the venting tables shall be reduced by 10 percent.

**G2428.3.7 Elbows in connectors.** The vent connector capacities listed in the common vent sizing tables include allowance for two 90-degree (1.57 rad) elbows. For each additional elbow up to and including 45 degrees (0.79 rad), the maximum vent connector capacity listed in the venting tables shall be reduced by 5 percent. For each elbow greater than 45 degrees (0.79 rad) up to and including 90 degrees (1.57 rad), the maximum vent connector capacity listed in the venting tables shall be reduced by 10 percent.

**G2428.3.8 Common vent minimum size.** The cross-sectional area of the common vent shall be equal to or greater than the cross-sectional area of the largest connector.

**G2428.3.9 Common vent fittings.** At the point where tee or wye fittings connect to a common vent, the opening size of the fitting shall be equal to the size of the common vent. Such fittings shall not be prohibited from having reduced-size openings at the point of connection of appliance vent connectors.

**G2428.3.10 High altitude installations.** Sea-level input ratings shall be used when determining maximum capacity for high altitude installation. Actual input, derated for altitude, shall be used for determining minimum capacity for high altitude installation.

**G2428.3.11 Connector rise measurement.** Connector rise (R) for each appliance connector shall be measured from the draft hood outlet or flue collar to the centerline where the vent gas streams come together.

**G2428.3.12 Vent height measurement.** For multiple units of equipment all located on one floor, available total height (H) shall be measured from the highest draft hood outlet or flue collar up to the level of the outlet of the common vent.

**G2428.3.13 Vertical vent maximum size.** Where two or more appliances are connected to a vertical vent or chimney, the flow area of the largest section of vertical vent or chimney shall not exceed seven times the smallest listed appliance categorized vent areas, flue collar area, or draft hood outlet area unless designed in accordance with approved engineering methods.

**G2428.3.14 Multiple input rate appliances.** For appliances with more than one input rate, the minimum vent connector capacity (FAN Min) determined from the tables shall be less than the lowest appliance input rating, and the maximum vent connector capacity (FAN Max or NAT Max) determined from the tables shall be greater than the highest appliance input rating.

**G2428.3.15 Liner system sizing.** Listed, corrugated metallic chimney liner systems in masonry chimneys shall be sized by using Table G2428.3(1) or G2428.3(2) for Type B vents, with the maximum capacity reduced by 20 percent

(0.80 × maximum capacity) and the minimum capacity as shown in Table G2428.3(1) or G2428.3(2). Corrugated metallic liner systems installed with bends or offsets shall have their maximum capacity further reduced in accordance with Sections G2428.3.5 and G2428.3.6. The 20-percent reduction for corrugated metallic chimney liner systems includes an allowance for one long-radius 90-degree (1.57 rad) turn at the bottom of the liner.

**G2428.3.16 Chimney and vent location.** Tables G2428.3(1), G2428.3(2), G2428.3(3) and G2428.3(4) shall be used for chimneys and vents not exposed to the outdoors below the roof line. A Type B vent or listed chimney lining system passing through an unused masonry chimney flue shall not be considered to be exposed to the outdoors.

**Exception:** Vents serving listed appliances installed in accordance with the appliance manufacturer's instructions and the terms of the listing.

**G2428.3.17 Connector maximum and minimum size.** Vent connectors shall not be increased in size more than two sizes greater than the listed appliance categorized vent diameter, flue collar diameter, or draft hood outlet diameter. Vent connectors for draft-hood-equipped appliances shall not be smaller than the draft hood outlet diameter. Where a vent connector size(s) determined from the tables for a fan-assisted appliance(s) is smaller than the flue collar diameter, the use of the smaller size(s) shall be permitted provided that the installation complies with all of the following conditions:

1. Vent connectors for fan-assisted appliance flue collars 12 inches (305 mm) in diameter or smaller are not reduced by more than one table size [e.g., 12 inches to 10 inches (305 mm to 254 mm) is a one-size reduction] and those larger than 12 inches (305 mm) in diameter are not reduced more than two table sizes [e.g., 24 inches to 20 inches (610 mm to 508 mm) is a two-size reduction].
2. The fan-assisted appliance(s) is common vented with a draft-hood-equipped appliances(s).
3. The vent connector has a smooth interior wall.

**G2428.3.18 Component commingling.** All combinations of pipe sizes, single-wall, and double-wall metal pipe shall be allowed within any connector run(s) or within the common vent, provided all of the appropriate tables permit all of the desired sizes and types of pipe, as if they were used for the entire length of the subject connector or vent. Where single-wall and Type B double-wall metal pipes are used for vent connectors within the same venting system, the common vent must be sized using Table G2428.3(2) or G2428.3(4), as appropriate.

**G2428.3.19 Multiple sizes permitted.** Where a table permits more than one diameter of pipe to be used for a connector or vent, all the permitted sizes shall be permitted to be used.

**G2428.3.20 Table interpolation.** Interpolation shall be permitted in calculating capacities for vent dimensions that fall between table entries. (See Example 3, Appendix B.)

**G2428.3.21 Extrapolation prohibited.** Extrapolation beyond the table entries shall not be permitted.

**G2428.3.22 Engineering calculations.** For vent heights less than 6 feet (1829 mm) and greater than shown in the tables, engineering methods shall be used to calculate vent capacities.

### SECTION G2429 DIRECT-VENT, INTEGRAL VENT, MECHANICAL VENT AND VENTILATION/EXHAUST HOOD VENTING

**G2429.1 General.** The installation of direct-vent and integral vent appliances shall be in accordance with Section G2427. Mechanical venting systems shall be designed and installed in accordance with Section G2427.

### SECTION G2430 FACTORY-BUILT CHIMNEYS

**G2430.1 Listing.** Factory-built chimneys for building heating appliances producing flue gases having a temperature not greater than 1,000°F (538°C), measured at the entrance to the chimney, shall be listed and labeled in accordance with UL 103 and shall be installed and terminated in accordance with the manufacturer's installation instructions.

**G2430.2 Support.** Where factory-built chimneys are supported by structural members, such as joists and rafters, such members shall be designed to support the additional load.

### SECTION G2431 GENERAL

**G2431.1 Scope.** This chapter shall govern the approval, design, installation, construction, alteration and repair of the appliances and equipment specifically identified herein.

### SECTION G2432 DECORATIVE APPLIANCES FOR INSTALLATION IN FIREPLACES

**G2432.1 General.** Decorative appliances for installation in approved solid fuel burning fireplaces shall be tested in accordance with ANSI Z21.60 and shall be installed in accordance with the manufacturer's installation instructions.

**G2432.2 Flame safeguard device.** Decorative appliances for installation in approved solid fuel-burning fireplaces shall utilize a direct ignition device, an ignitor or a pilot flame to ignite the fuel at the main burner, and shall be equipped with a flame safeguard device. The flame safeguard device shall automatically shut off the fuel supply to a main burner or group of burners when the means of ignition of such burners becomes inoperative.

**G2432.3 Prohibited installations.** Decorative appliances for installation in fireplaces shall not be installed where prohibited by Section G2406.2.

### SECTION G2433 LOG LIGHTERS

**G2433.1 General.** Log lighters shall be installed in accordance with the manufacturer's installation instructions. <

### SECTION G2434 VENTED GAS FIREPLACES (DECORATIVE APPLIANCES)

**G2434.1 General.** Vented gas fireplaces shall be tested in accordance with ANSI Z21.50, shall be installed in accordance with the manufacturer's installation instructions and shall be designed and equipped as specified in Section G2432.2.

**G2434.2 Access.** Panels, grilles, and access doors that are required to be removed for normal servicing operations shall not be attached to the building.

### SECTION G2435 VENTED GAS FIREPLACE HEATERS

**G2435.1 General.** Vented gas fireplace heaters shall be installed in accordance with the manufacturer's installation instructions, shall be tested in accordance with ANSI Z21.88 and shall be designed and equipped as specified in Section G2432.2.

### SECTION G2436 VENTED WALL FURNACES

**G2436.1 General.** Vented wall furnaces shall be tested in accordance with ANSI Z21.49 or Z21.86/CSA 2.32 and shall be installed in accordance with the manufacturer's installation instructions.

**G2436.2 Venting.** Vented wall furnaces shall be vented in accordance with Section G2427.

**G2436.3 Location.** Vented wall furnaces shall be located so as not to cause a fire hazard to walls, floors, combustible furnishings or doors. Vented wall furnaces installed between bathrooms and adjoining rooms shall not circulate air from bathrooms to other parts of the building.

**G2436.4 Door swing.** Vented wall furnaces shall be located so that a door cannot swing within 12 inches (305 mm) of an air inlet or air outlet of such furnace measured at right angles to the opening. Doorstops or door closers shall not be installed to obtain this clearance.

**G2436.5 Ducts prohibited.** Ducts shall not be attached to wall furnaces. Casing extension boots shall not be installed unless listed as part of the appliance.

**G2436.6 Access.** Vented wall furnaces shall be provided with access for cleaning of heating surfaces, removal of burners, replacement of sections, motors, controls, filters and other working parts, and for adjustments and lubrication of parts requiring such attention. Panels, grilles and access doors that are required to be removed for normal servicing operations shall not be attached to the building construction.

FUEL GAS

**SECTION G2437  
FLOOR FURNACES**

**G2437.1 General.** Floor furnaces shall be tested in accordance with ANSI Z21.48 or Z21.86/CSA 2.32 and shall be installed in accordance with the manufacturer's installation instructions.

**G2437.2 Placement.** The following provisions apply to floor furnaces:

1. Floors. Floor furnaces shall not be installed in the floor of any doorway, stairway landing, aisle or passageway of any enclosure, public or private, or in an exitway from any such room or space.
2. Walls and corners. The register of a floor furnace with a horizontal warm air outlet shall not be placed closer than 6 inches (152 mm) to the nearest wall. A distance of at least 18 inches (457 mm) from two adjoining sides of the floor furnace register to walls shall be provided to eliminate the necessity of occupants walking over the warm air discharge. The remaining sides shall be permitted to be placed not closer than 6 inches (152 mm) to a wall. Wall-register models shall not be placed closer than 6 inches (152 mm) to a corner.
3. Draperies. The furnace shall be placed so that a door, drapery, or similar object cannot be nearer than 12 inches (305 mm) to any portion of the register of the furnace.
4. Floor construction. Floor furnaces shall not be installed in concrete floor construction built on grade.
5. Thermostat. The controlling thermostat for a floor furnace shall be located within the same room or space as the floor furnace or shall be located in an adjacent room or space that is permanently open to the room or space containing the floor furnace.

**G2437.3 Bracing.** The floor around the furnace shall be braced and headed with a support framework designed in accordance with Chapter 5.

**G2437.4 Clearance.** The lowest portion of the floor furnace shall have not less than a 6-inch (152 mm) clearance from the grade level; except where the lower 6-inch (152 mm) portion of the floor furnace is sealed by the manufacturer to prevent entrance of water, the minimum clearance shall be reduced to not less than 2 inches (51 mm). Where these clearances cannot be provided, the ground below and to the sides shall be excavated to form a pit under the furnace so that the required clearance is provided beneath the lowest portion of the furnace. A 12-inch (305 mm) minimum clearance shall be provided on all sides except the control side, which shall have an 18-inch (457 mm) minimum clearance.

**G2437.5 First floor installation.** Where the basement story level below the floor in which a floor furnace is installed is utilized as habitable space, such floor furnaces shall be enclosed as specified in Section G2437.6 and shall project into a nonhabitable space.

**G2437.6 Upper floor installations.** Floor furnaces installed in upper stories of buildings shall project below into nonhabitable space and shall be separated from the nonhabitable space by an enclosure constructed of noncombustible materials. The floor furnace shall be provided with access, clearance to all sides and

bottom of not less than 6 inches (152 mm) and combustion air in accordance with Section G2407.

**SECTION G2438  
CLOTHES DRYERS**

**G2438.1 General.** Clothes dryers shall comply with the provisions of Section M1501.

**SECTION G2439  
ENGINE AND GAS TURBINE-POWERED  
EQUIPMENT**

**G2439.1 Powered equipment.** Permanently installed equipment powered by internal combustion engines and turbines shall be installed in accordance with the manufacturer's installation instructions and in accordance with NFPA 37.

**SECTION G2440  
SAUNA HEATERS**

**G2440.1 General.** Sauna heaters shall be installed in accordance with the manufacturer's installation instructions and Section M1902.

**G2440.2 Combustion and dilution air intakes.** Sauna heaters of other than the direct-vent type shall be installed with the draft hood and combustion air intake located outside the sauna room. Where the combustion air inlet and the draft hood are in a dressing room adjacent to the sauna room, there shall be provisions to prevent physically blocking the combustion air inlet and the draft hood inlet, and to prevent physical contact with the draft hood and vent assembly, or warning notices shall be posted to avoid such contact. Any warning notice shall be easily readable, shall contrast with its background, and the wording shall be in letters not less than 0.25 inch (6.4 mm) high.

**G2440.3 Combustion air.** Combustion air shall not be taken from inside the sauna room. Combustion air for a sauna heater not of the direct-vent type shall be provided to the area in which the combustion air inlet and draft hood are located in accordance with Section G2407.

**SECTION G2441  
POOL AND SPA HEATERS**

**G2441.1 General.** Pool and spa heaters shall be tested in accordance with ANSI Z21.56 and shall be installed in accordance with the manufacturer's installation instructions and, where applicable, Section E39-680.

**SECTION G2442  
FORCED-AIR WARM-AIR FURNACES**

**G2442.1 General.** Forced-air warm-air furnaces shall be tested in accordance with ANSI Z21.47 or UL 795 and shall be installed in accordance with the manufacturer's installation instructions.

**G2442.2 Forced-air furnaces.** The minimum unobstructed total area of the outside and return air ducts or openings to a

forced-air warm-air furnace shall be not less than 2 square inches for each 1,000 Btu/h (4402 mm<sup>2</sup>/W) output rating capacity of the furnace and not less than that specified in the furnace manufacturer's installation instructions. The minimum unobstructed total area of supply ducts from a forced-air warm-air furnace shall be not less than 2 square inches for each 1,000 Btu/h (4402 mm<sup>2</sup>/W) output rating capacity of the furnace and not less than that specified in the furnace manufacturer's installation instructions.

**Exception:** The total area of the supply air ducts and outside and return air ducts shall not be required to be larger than the minimum size required by the furnace manufacturer's installation instructions.

**G2442.3 Dampers.** Volume dampers shall not be placed in the air inlet to a furnace in a manner that will reduce the required air to the furnace.

**G2442.4 Circulating air ducts for forced-air warm-air furnaces.** Circulating air for forced-air-type, warm-air furnaces shall be conducted into the blower housing from outside the furnace enclosure by continuous air-tight ducts.

**G2442.5 Prohibited sources.** Outside or return air for a forced-air heating system shall not be taken from the following locations:

1. Closer than 10 feet (3048 mm) from an appliance vent outlet, a vent opening from a plumbing drainage system or the discharge outlet of an exhaust fan, unless the outlet is 3 feet (914 mm) above the outside air inlet.

**Exception:** Listed outdoor appliances which provide both circulating air and vent discharge.

2. Where there is the presence of objectionable odors, fumes or flammable vapors; or where located less than 10 feet (3048 mm) above the surface of any abutting public way or driveway; or where located at grade level by a sidewalk, street, alley or driveway.
3. A room or space, the volume of which is less than 25 percent of the entire volume served by such system. Where connected by a permanent opening having an area sized in accordance with Section G2442.2, adjoining rooms or spaces shall be considered as a single room or space for the purpose of determining the volume of such rooms or spaces.

**Exception:** The minimum volume requirement shall not apply where the amount of return air taken from a room or space is less than or equal to the amount of supply air delivered to such room or space.

4. A room or space containing an appliance where such a room or space serves as the sole source of return air.

**Exception:** This shall not apply where:

1. The appliance is a direct-vent appliance or an appliance not requiring a vent in accordance with Section G2429.8.
2. The room or space complies with the following requirements:
  - 2.1. The return air shall be taken from a room or space having a volume exceeding 1 cubic foot (28 316.85 mm<sup>3</sup>) for

each 10 Btu/h (9.6 L/W) of combined input rating of all fuel-burning appliances therein.

- 2.2. The volume of supply air discharged back into the same space shall be approximately equal to the volume of return air taken from the space.

- 2.3. Return-air inlets shall not be located within 10 feet (3048 mm) of any appliance firebox or draft hood in the same room or space.

3. Rooms or spaces containing solid-fuel burning appliances, provided that return-air inlets are located not less than 10 feet (3048 mm) from the firebox of such appliances.

5. A closet, bathroom, toilet room, kitchen, garage, mechanical room, boiler room or furnace room.

**G2442.6 Screen.** Required outdoor air inlets shall be covered with a screen having  $\frac{1}{4}$ -inch (6.4 mm) openings. Required outdoor air inlets serving a nonresidential portion of a building shall be covered with screen having openings larger than  $\frac{1}{4}$  inch (6.4 mm) and not larger than 1 inch (25 mm).

**G2442.7 Return-air limitation.** Return air from one dwelling unit shall not be discharged into another dwelling unit.

## SECTION G2443 CONVERSION BURNERS

**G2443.1 Conversion burners.** The installation of conversion burners shall conform to ANSI Z21.8.

## SECTION G2444 UNIT HEATERS

**G2444.1 General.** Unit heaters shall be tested in accordance with ANSI Z83.8 and shall be installed in accordance with the manufacturer's installation instructions.

**G2444.2 Support.** Suspended-type unit heaters shall be supported by elements that are designed and constructed to accommodate the weight and dynamic loads. Hangers and brackets shall be of noncombustible material.

**G2444.3 Ductwork.** Ducts shall not be connected to a unit heater unless the heater is listed for such installation.

**G2444.4 Clearance.** Suspended-type unit heaters shall be installed with clearances to combustibles of not less than 18 inches (457 mm) at the sides, 12 inches (305 mm) at the bottom and 6 inches (152 mm) above the top where the unit heater has an internal draft hood or 1 inch (25 mm) above the top of the sloping side of the vertical draft hood.

Floor-mounted-type unit heaters shall be installed with clearances to combustibles at the back and one side only of not less than 6 inches (152 mm). Where the flue gases are vented horizontally, the 6-inch (152 mm) clearance shall be measured from the draft hood or vent instead of the rear wall of the unit heater. Floor-mounted-type unit heaters shall not be installed on combustibles floors unless listed for such installation.

## FUEL GAS

Clearance for servicing all unit heaters shall be in accordance with the manufacturer's installation instructions.

**Exception:** Unit heaters listed for reduced clearance shall be permitted to be installed with such clearances in accordance with their listing and the manufacturer's instructions.

### SECTION G2445 (621) UNVENTED ROOM HEATERS

**G2445.1 General.** Unvented room heaters shall be tested in accordance with ANSI Z 21.11.2 and shall be installed in accordance with the conditions of the listing and the manufacturer's installation instructions.

**G2445.2 Prohibited use.** One or more unvented room heaters shall not be used as the sole source of comfort heating in a dwelling unit.

**G2445.3 Input rating.** Unvented room heaters shall not have an input rating in excess of 40,000 Btu/h (11.7 kW).

**G2445.4 Prohibited locations.** The location of unvented room heaters shall comply with Section G2406.2.

**G2445.5 Room or space volume.** The aggregate input rating of all unvented appliances installed in a room or space shall not exceed 20 Btu/h per cubic foot (0.21 kW/m<sup>3</sup>) of volume of such room or space. Where the room or space in which the equipment is installed is directly connected to another room or space by a doorway, archway or other opening of comparable size that cannot be closed, the volume of such adjacent room or space shall be permitted to be included in the calculations.

**G2445.6 Oxygen-depletion safety system.** Unvented room heaters shall be equipped with an oxygen-depletion-sensitive safety shutoff system. The system shall shut off the gas supply to the main and pilot burners when the oxygen in the surrounding atmosphere is depleted to the percent concentration specified by the manufacturer, but not lower than 18 percent. The system shall not incorporate field adjustment means capable of changing the set point at which the system acts to shut off the gas supply to the room heater.

**G2445.7 Unvented log heaters.** An unvented log heater shall not be installed in a factory-built fireplace unless the fireplace system has been specifically tested, listed and labeled for such use in accordance with UL 127.

### SECTION G2446 VENTED ROOM HEATERS

**G2446.1 General.** Vented room heaters shall be tested in accordance with ANSI Z21.11.1 or ANSI Z21.86/CSA 2.32, shall be designed and equipped as specified in Section G2432.2 and shall be installed in accordance with the manufacturer's installation instructions.

### SECTION G2447 COOKING APPLIANCES

**G2447.1 Cooking appliances.** Cooking appliances that are designed for permanent installation, including ranges, ovens, stoves, broilers, grills, fryers, griddles, hot plates and barbe-

cues, shall be tested in accordance with ANSI Z21.1 or ANSI Z21.58 and shall be installed in accordance with the manufacturer's installation instructions.

**G2447.2 Prohibited location.** Cooking appliances designed, tested, listed and labeled for use in commercial occupancies shall not be installed within dwelling units or within any area where domestic cooking operations occur.

**G2447.3 Domestic appliances.** Cooking appliances installed within dwelling units and within areas where domestic cooking operations occur shall be listed and labeled as household-type appliances for domestic use.

**G2447.4 Range installation.** Ranges installed on combustible floors shall be set on their own bases or legs and shall be installed with clearances of not less than that shown on the label.

### SECTION G2448 WATER HEATERS

**G2448.1 General.** Water heaters shall be tested in accordance with ANSI Z 21.10.1 and ANSI Z 21.10.3 and shall be installed in accordance with the manufacturer's installation instructions and the plumbing chapters of this code.

**G2448.1.1 Installation requirements.** The requirements for water heaters relative to relief valves, drain pans and scald protection shall be in accordance with the plumbing chapters of this code.

**G2448.2 Water heaters utilized for space heating.** Water heaters utilized both to supply potable hot water and provide hot water for space-heating applications shall be listed and labeled for such applications by the manufacturer and shall be installed in accordance with the manufacturer's installation instructions, Section M2004 and the plumbing section of this code.

### SECTION G2449 AIR-CONDITIONING EQUIPMENT

**G2449.1 General.** Air conditioning equipment shall be tested in accordance with ANSI Z21.40.1 or ANSI Z21.40.2 and shall be installed in accordance with the manufacturer's installation instructions.

**G2449.2 Independent piping.** Gas piping serving heating equipment shall be permitted to also serve cooling equipment where such heating and cooling equipment cannot be operated simultaneously. (See Section G2413.)

**G2449.3 Connection of gas engine-powered air conditioners.** To protect against the effects of normal vibration in service, gas engines shall not be rigidly connected to the gas supply piping.

**G2449.4 Installation.** Air conditioning equipment shall be installed in accordance with the manufacturer's instructions. Unless the equipment is listed for installation on a combustible surface such as a floor or roof, or unless the surface is protected in an approved manner, equipment shall be installed on a surface of noncombustible construction with noncombustible material and surface finish and with no combustible material against the underside thereof.

**SECTION G2450  
 ILLUMINATING APPLIANCES**

**G2450.1 General.** Illuminating appliances shall be tested in accordance with ANSI Z21.42 and shall be installed in accordance with the manufacturer's installation instructions.

**G2450.2 Mounting on buildings.** Illuminating appliances designed for wall or ceiling mounting shall be securely attached to substantial structures in such a manner that they are not dependent on the gas piping for support.

**G2450.3 Mounting on posts.** Illuminating appliances designed for post mounting shall be securely and rigidly attached to a post. Posts shall be rigidly mounted. The strength and rigidity of posts greater than 3 feet (914 mm) in height shall be at least equivalent to that of a 2.5-inch-diameter (64 mm) post constructed of 0.064-inch-thick (1.6 mm) steel or a 1-inch (25 mm) Schedule 40 steel pipe. Posts 3 feet (914 mm) or less in height shall not be smaller than 3/4-inch (19.1 mm) Schedule 40 steel pipe. Drain openings shall be provided near the base of posts where there is a possibility of water collecting inside them.

**G2450.4 Appliance pressure regulators.** Where an appliance pressure regulator is not supplied with an illuminating appliance and the service line is not equipped with a service pressure regulator, an appliance pressure regulator shall be in-

stalled in the line to the illuminating appliance. For multiple installations, one regulator of adequate capacity shall be permitted to serve more than one illuminating appliance.

**SECTION G2451  
 INFRARED RADIANT HEATERS**

**G2451.1 General.** Infrared radiant heaters shall be tested in accordance with ANSI Z 83.6 and shall be installed in accordance with the manufacturer's installation instructions.

**G2451.2 Support.** Infrared radiant heaters shall be safely and adequately fixed in an approved position independent of gas and electric supply lines. Hanger and brackets shall be of non-combustible material.

**SECTION G2452  
 CHIMNEY DAMPER OPENING AREA**

**G2452.1 Free opening area of chimney dampers.** Where an unlisted decorative appliance for installation in a vented fireplace is installed, the fireplace damper shall have a permanent free opening equal to or greater than specified in Table G2452.1.

**TABLE G2452.1  
 FREE OPENING AREA OF CHIMNEY DAMPER FOR VENTING FLUE GASES  
 FROM UNLISTED DECORATIVE APPLIANCES FOR INSTALLATION IN VENTED FIREPLACES**

CHIMNEY HEIGHT (feet)	MINIMUM PERMANENT FREE OPENING (square inches) <sup>a</sup>						
	8	13	20	29	39	51	64
	Appliance input rating (Btu per hour)						
6	7,800	14,000	23,200	34,000	46,400	62,400	80,000
8	8,400	15,200	25,200	37,000	50,400	68,000	86,000
10	9,000	16,800	27,600	40,400	55,800	74,400	96,400
15	9,800	18,200	30,200	44,600	62,400	84,000	108,800
20	10,600	20,200	32,600	50,400	68,400	94,000	122,200
30	11,200	21,600	36,600	55,200	76,800	105,800	138,600

For SI: 1 foot = 304.8 mm, 1 square inch = 645.16 mm<sup>2</sup>, 1,000 Btu per hour = 0.293 kW.

a. The first six minimum permanent free openings (8 square inches to 51 square inches) correspond approximately to the cross-sectional areas of chimneys having diameters of 3 inches through 8 inches, respectively. The 64-square inch opening corresponds to the cross-sectional area of standard 8-inch by 8-inch chimney tile.

