

CHAPTER 13

GENERAL MECHANICAL SYSTEM REQUIREMENTS

SECTION M1301 GENERAL

M1301.1 Scope. The provisions of this chapter shall govern the installation of mechanical systems not specifically covered in other chapters applicable to mechanical systems. Installations of mechanical appliances, equipment and systems not addressed by this code shall comply with the applicable provisions of the *International Mechanical Code*.

M1301.1.1 Flood-resistant installation. In flood hazard areas, mechanical appliances, equipment and systems shall be located or installed in accordance with the *Phoenix City Code*.

SECTION M1302 APPROVAL

M1302.1 General. All appliances shall be listed and bear the label of an approved agency unless otherwise approved in accordance with Section 104.10 of the *Phoenix Building Construction Code—Administration Provisions*.

Exception: Unlisted appliances shall be evaluated by a listing agency or a qualified professional engineer and approved by the building official. A report addressing the appliance shall be submitted to the building official for approval as specified in the *International Mechanical Code*.

SECTION M1303 LABELING OF APPLIANCES

M1303.1 Label information. A permanent factory-applied nameplate(s) shall be affixed to appliances on which shall appear, in legible lettering, the manufacturer's name or trademark, the model number, serial number, and the seal or mark of the testing agency. A label shall also include the following

1. Electrical appliances. Electrical rating in volts, amperes and motor phase; identification of individual electrical components in volts, amperes or watts, and motor phase; and in Btu/h (W) output and required clearances.
2. Absorption units. Hourly rating in Btu/h (W), minimum hourly rating for units having step or automatic modulating controls, type of fuel, type of refrigerant, cooling capacity in Btu/h (W), and required clearances.
3. Fuel-burning units. Hourly rating in Btu/h (W), type of fuel approved for use with the appliance and required clearances.
4. Electric comfort heating appliances. Name and trademark of the manufacturer; the model number or equivalent; the electric rating in volts, ampacity and phase; Btu/h (W) output rating; individual marking for each

electrical component in amperes or watts, volts and phase; required clearances from combustibles; and a seal indicating approval of the appliance by an approved agency.

SECTION M1304 TYPE OF FUEL

M1304.1 Fuel types. Fuel-fired appliances shall be designed for use with the type of fuel to which they will be connected and the altitude at which they are installed. Appliances that comprise parts of the building mechanical system shall not be converted for the usage of a different fuel, except where approved and converted in accordance with the manufacturer's instructions. The fuel input rate shall not be increased or decreased beyond the limit rating for the altitude at which the appliance is installed.

SECTION M1305 APPLIANCE ACCESS

M1305.1 Appliance access for inspection service, repair and replacement. Appliances shall be accessible for inspection, service, repair and replacement without removing permanent construction. Thirty inches (762 mm) of working space shall be provided in front of the control side to service an appliance. Room heaters shall be permitted to be installed with at least an 18-inch (457 mm) working space. A platform shall not be required for room heaters.

M1305.1.1 Central furnaces. Central furnaces within compartments or alcoves shall have a minimum working space clearance of 3 inches (76 mm) along the sides, back and top with a total width of the enclosing space being at least 12 inches (305 mm) wider than the furnace. Furnaces having a firebox open to the atmosphere shall have at least a 6-inch (152 mm) working space along the front combustion chamber side. Combustion air openings at the rear or side of the compartment shall comply with the requirements of Chapter 17.

Exception: This section shall not apply to replacement appliances installed in existing compartments and alcoves where the working space clearances are in accordance with the equipment or appliance manufacturer's installation instructions.

M1305.1.2 Appliances in rooms. Appliances installed in a compartment, alcove, basement or similar space shall be accessed by an opening or door and an unobstructed passageway measuring not less than 24 inches (610 mm) wide and large enough to allow removal of the largest appliance in the space, provided that a level service space of not less than 30

GENERAL MECHANICAL SYSTEM REQUIREMENTS

inches (762 mm) deep and the height of the appliance, but not less than 30 inches (762 mm), is present at the front or service side of the appliance with the door open.

M1305.1.3 Appliances in attics. Attics containing appliances requiring access shall be provided with an opening and a clear and unobstructed passageway large enough to allow removal of the largest appliance, but not less than 30 inches (762 mm) high and 22 inches (559 mm) wide and not more than 20 feet (6096 mm) in length when measured along the centerline of the passageway from the opening to the appliance. The passageway shall have continuous solid flooring in accordance with Chapter 5 not less than 24 inches (610 mm) wide. A level service space at least 30 inches (762 mm) deep and 30 inches (762 mm) wide shall be present along all sides of the appliance where access is required. The clear access opening dimensions shall be a minimum of 20 inches by 30 inches (508 mm by 762 mm), where such dimensions are large enough to allow removal of the largest appliance.

Exception: The passageway and level service space are not required where the appliance is capable of being serviced and removed through the required opening.

M1305.1.3.1 Electrical requirements. A lighting fixture controlled by a switch located at the required passageway opening and a receptacle outlet shall be provided at or near the appliance location in accordance with the *National Electrical Code*.

M1305.1.4 Appliances under floors. Underfloor spaces containing appliances requiring access shall be provided with an unobstructed passageway large enough to remove the largest appliance, but not less than 30 inches (762 mm) high and 22 inches (559 mm) wide, nor more than 20 feet (6096 mm) in length when measured along the centerline of the passageway from the opening to the appliance. A level service space at least 30 inches (762 mm) deep and 30 inches (762 mm) wide shall be present at the front or service side of the appliance. If the depth of the passageway or the service space ex-

ceeds 12 inches (305 mm) below the adjoining grade, the walls of the passageway shall be lined with concrete or masonry extending 4 inches (102 mm) above the adjoining grade in accordance with Chapter 4. The rough-framed access opening dimensions shall be a minimum of 22 inches by 30 inches (559 mm by 762 mm), where the dimensions are large enough to remove the largest appliance.

Exception: The passageway is not required where the level service space is present when the access is open, and the appliance is capable of being serviced and removed through the required opening.

M1305.1.4.1 Ground clearance. Appliances supported from the ground shall be level and firmly supported on a concrete slab or other approved material extending above the adjoining ground. Appliances suspended from the floor shall have a clearance of not less than 6 inches (152 mm) from the ground.

M1305.1.4.2 Excavations. Excavations for appliance installations shall extend to a depth of 6 inches (152 mm) below the appliance and 12 inches (305 mm) on all sides, except that the control side shall have a clearance of 30 inches (762 mm).

M1305.1.4.3 Electrical requirements. A lighting fixture controlled by a switch located at the required passageway opening and a receptacle outlet shall be provided at or near the appliance location in accordance with the *National Electrical Code*.

SECTION M1306 CLEARANCES FROM COMBUSTIBLE CONSTRUCTION

M1306.1 Appliance clearance. Appliances shall be installed with the clearances from unprotected combustible materials as indicated on the appliance label and in the manufacturer's installation instructions.

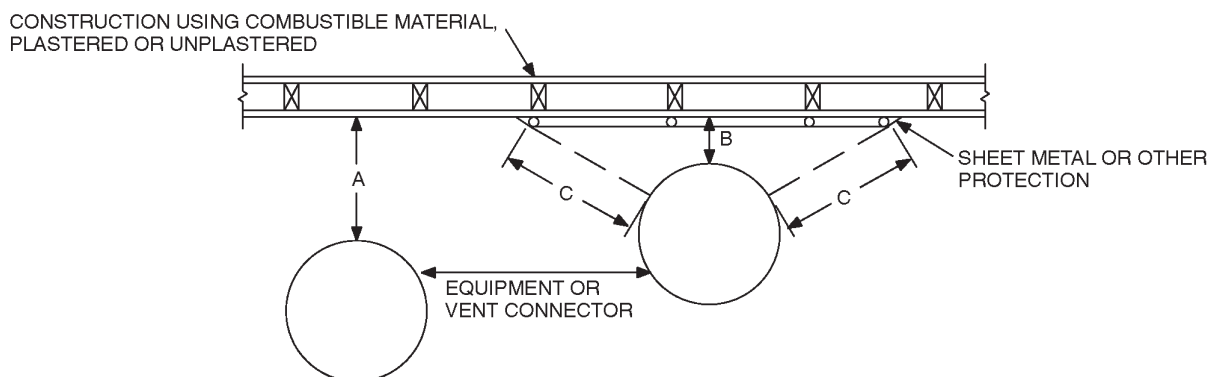

Note: “A” equals the required clearance with no protection. “B” equals the reduced clearance permitted in accordance with Table M1306.2. The protection applied to the construction using combustible material shall extend far enough in each direction to make “C” equal to “A.”

**FIGURE M1306.1
REDUCED CLEARANCE DIAGRAM**

M1306.2 Clearance reduction. Reduction of clearances shall be in accordance with the appliance manufacturer's instructions and Table M1306.2. Forms of protection with ventilated air space shall conform to the following requirements:

1. Not less than 1-inch (25.4 mm) air space shall be provided between the protection and combustible wall surface.
2. Air circulation shall be provided by having edges of the wall protection open at least 1 inch (25.4 mm).
3. If the wall protection is mounted on a single flat wall away from corners, air circulation shall be provided by having the bottom and top edges, or the side and top edges open at least 1 inch (25.4 mm).

4. Wall protection covering two walls in a corner shall be open at the bottom and top edges at least 1 inch (25.4 mm).

M1306.2.1 Solid fuel appliances. Table M1306.2 shall not be used to reduce the clearance required for solid fuel appliances listed for installation with minimum clearances of 12 inches (305 mm) or less. For appliances listed for installation with minimum clearances greater than 12 inches (305 mm), Table M1306.2 shall not be used to reduce the clearance to less than 12 inches (305 mm).

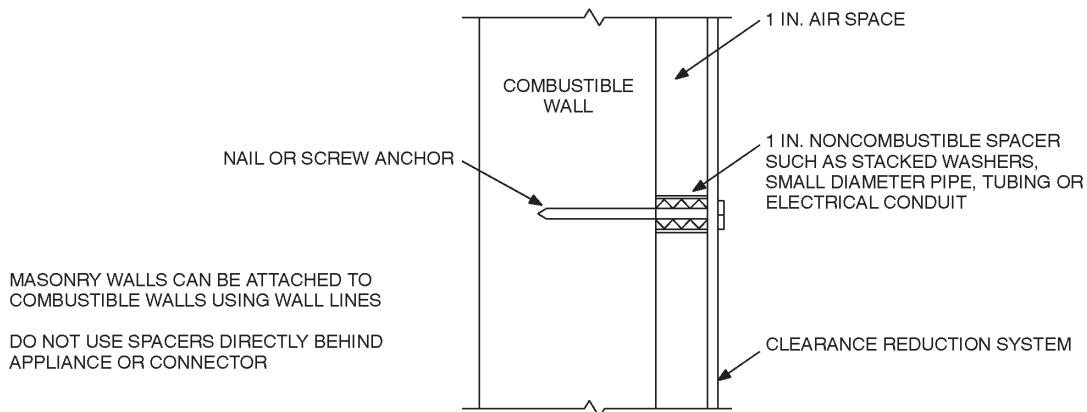
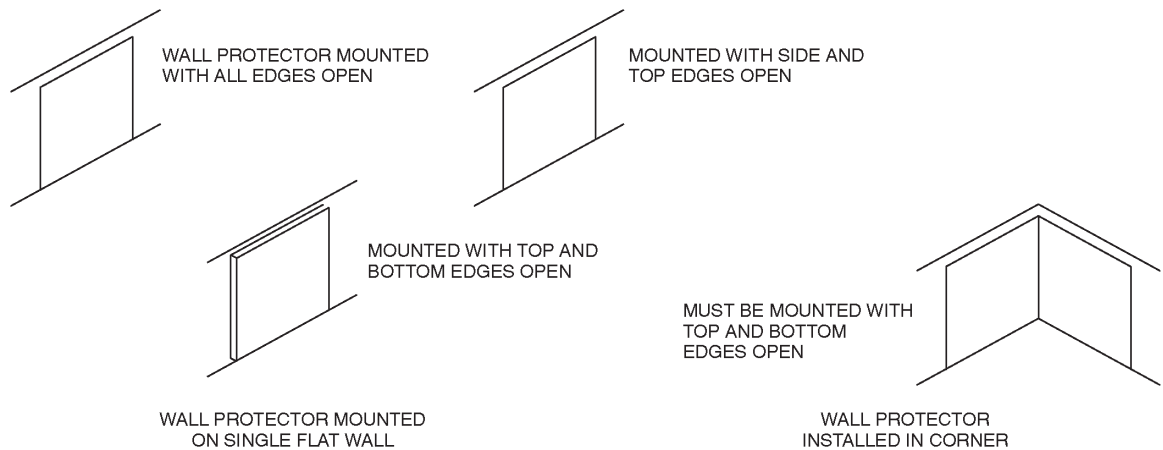

For SI: 1 inch = 25.4 mm.

FIGURE M1306.2
WALL PROTECTOR CLEARANCE REDUCTION SYSTEM

TABLE M1306.2
REDUCTION OF CLEARANCES WITH SPECIFIED FORMS OF PROTECTION^{a,b,c,d,e,f,g,h,i,j,k}

TYPE OF PROTECTION APPLIED TO AND COVERING ALL SURFACES OF COMBUSTIBLE MATERIAL WITHIN THE DISTANCE SPECIFIED AS THE REQUIRED CLEARANCE WITH NO PROTECTION [SEE Figures M1306.1 and M1306.2]	WHERE THE REQUIRED CLEARANCE WITH NO PROTECTION FROM APPLIANCE, VENT CONNECTOR, OR SINGLE WALL METAL PIPE IS:									
	36 inches		18 inches		12 inches		9 inches		6 inches	
	Allowable clearances with specified protection (Inches) ^b									
	Use column 1 for clearances above an appliance or horizontal connector. Use column 2 for clearances from an appliance, vertical connector and single-wall metal pipe.									
	Above column 1	Sides and rear column 2	Above column 1	Sides and rear column 2	Above column 1	Sides and rear column 2	Above column 1	Sides and rear column 2	Above column 1	Sides and rear column 2
3 1/2-inch thick masonry wall without ventilated air space	—	24	—	12	—	9	—	6	—	5
1/2-in. insulation board over 1-inch glass fiber or mineral wool batts	24	18	12	9	9	6	6	5	4	3
24 gage sheet metal over 1-inch glass fiber or mineral wool batts reinforced with wire on rear face with ventilated air space	18	12	9	6	6	4	5	3	3	3
3 1/2-inch thick masonry wall with ventilated air space	—	12	—	6	—	6	—	6	—	6
24 gage sheet metal with ventilated air space	18	12	9	6	6	4	5	3	3	2
1/2-inch thick insulation board with ventilated air space	18	12	9	6	6	4	5	3	3	3
24 gage sheet metal with ventilated air space over 24 gage sheet metal with ventilated air space	18	12	9	6	6	4	5	3	3	3
1-inch glass fiber or mineral wool batts sandwiched between two sheets 24 gage sheet metal with ventilated air space.	18	12	9	6	6	4	5	3	3	3

For SI: 1 inch = 25.4 mm, 1 pound per cubic foot = 16.019 kg/m³, °C = [(°F)-32/1.8], 1 Btu/(n · ft² · °F/in) = 0.001442299 (w/cm² · °C/cm).

- a. Reduction of clearances from combustible materials shall not interfere with combustion air, draft hood clearance and relief, and accessibility of servicing.
- b. Clearances shall be measured from the surface of the heat producing appliance or equipment to the outer surface of the combustible material or combustible assembly.
- c. Spacers and ties shall be of noncombustible material. No spacer or tie shall be used directly opposite appliance or connector.
- d. Where all clearance reduction systems use a ventilated air space, adequate provision for air circulation shall be provided as described. (See Figures M1306.1 and M1306.2.)
- e. There shall be at least 1 inch between clearance reduction systems and combustible walls and ceilings for reduction systems using ventilated air space.
- f. If a wall protector is mounted on a single flat wall away from corners, adequate air circulation shall be permitted to be provided by leaving only the bottom and top edges or only the side and top edges open with at least a 1-inch air gap.
- g. Mineral wool and glass fiber batts (blanket or board) shall have a minimum density of 8 pounds per cubic foot and a minimum melting point of 1,500°F.
- h. Insulation material used as part of a clearance reduction system shall have a thermal conductivity of 1.0 Btu inch per square foot per hour °F or less. Insulation board shall be formed of noncombustible material.
- i. There shall be at least 1 inch between the appliance and the protector. In no case shall the clearance between the appliance and the combustible surface be reduced below that allowed in Table M1306.2.
- j. All clearances and thicknesses are minimum; larger clearances and thicknesses are acceptable.
- k. Listed single-wall connectors shall be permitted to be installed in accordance with the terms of their listing and the manufacturer’s instructions.

SECTION M1307 APPLIANCE INSTALLATION

M1307.1 General. Installation of appliances shall conform to the conditions of their listing and label and the manufacturer's installation instructions. The manufacturer's operating and installation instructions shall remain attached to the appliance.

M1307.2 Anchorage of appliances. Appliances designed to be fixed in position shall be fastened or anchored in an approved manner. In Seismic Design Categories D₁ and D₂, water heaters shall be anchored or strapped to resist horizontal displacement due to earthquake motion. Strapping shall be at points within the upper one-third and lower one-third of the appliance's vertical dimensions. At the lower point, the strapping shall maintain a minimum distance of 4 inches (102 mm) above the controls.

M1307.3 Elevation of ignition source. Appliances having an ignition source shall be elevated such that the source of ignition is not less than 18 inches (457 mm) above the floor in garages. For the purpose of this section, rooms or spaces that are not part of the living space of a dwelling unit and that communicate with a private garage through openings shall be considered to be part of the garage.

M1307.3.1 Protection from impact. Appliances located in a garage or carport shall be protected from impact by automobiles.

M1307.4 Hydrogen generating and refueling operations. Ventilation shall be required in accordance with Section 1307.4.1, 1307.4.2 or 1307.4.3 in private garages which contain hydrogen generating appliances or refueling systems. Such spaces shall be used for the storage of not more than three hydrogen-fueled passenger motor vehicles and have a floor area not exceeding 850 square feet (79 m²). The maximum rated output capacity of hydrogen generating appliances shall not exceed 4 SCFM of hydrogen for each 250 square feet (23.2 m²) of floor area in such spaces. For the purpose of this section, rooms or spaces that are not part of the living space of a dwelling unit and that communicate directly with a private garage through openings shall be considered to be part of the private garage.

M1307.4.1 Natural ventilation. Indoor locations intended for hydrogen generating or refueling operations shall communicate with the outdoors in accordance with Sections 1307.4.1.1 through 1307.4.1.2. The minimum dimension of air openings shall be not less than 3 inches (76 mm). Where ducts are used, they shall be of the same cross-sectional area as the free area of the openings to which they connect. In such locations, equipment and appliances having an ignition source shall be located such that the source of ignition is not less than 12 inches (228 mm) below the ceiling.

M1307.4.1.1 Two openings. Two permanent openings, one located entirely within 12 inches (305 mm) of the ceiling of the garage, and one located entirely within 12 inches (305 mm) of the floor of the garage, shall be provided in the same exterior wall. The openings shall communicate directly, or by ducts, with the outdoors. Each opening shall directly communicate with the outdoors horizontally, and have a minimum free area of 1/2 square foot per 1,000 cubic feet (1 m²/610 m³) of garage volume.

M1307.4.1.2 Louvers and grilles. In calculating free area required by Section 1307.4.1, the required size of openings shall be based on the net free area of each opening. If the free area through a design of louver or grille is known, it shall be used in calculating the size opening required to provide the free area specified. If the design and free area are not known, it shall be assumed that wood louvers will have a 25-percent free area and metal louvers and grilles will have a 75-percent free area. Louvers and grilles shall be fixed in the open position.

M1307.4.2 Mechanical ventilation. Indoor locations intended for hydrogen generating or refueling operations shall be ventilated in accordance with Section 502.16 of the *International Mechanical Code*.

M1307.4.3 Specially engineered installations. As an alternative to the provisions of Sections 1307.4.1 and 1307.4.2, the necessary supply of air for ventilation and dilution of flammable gases shall be provided by an approved engineered system.

M1307.5 Electrical appliances. Electrical appliances shall be installed in accordance with Chapters 14, 15, 19 and 20 of this code and the provisions of the *National Electrical Code*.

M1307.6 Liquefied petroleum appliances. LP-gas appliances shall not be installed in an attic, pit or other location that would cause a ponding or retention of gas.

SECTION M1308 MECHANICAL SYSTEMS INSTALLATION

M1308.1 Drilling and notching. Wood-framed structural members shall be drilled, notched or altered in accordance with the provisions of Sections R502.8, R602.6, R602.6.1 and R802.7. Holes in cold-formed, steel-framed, load-bearing members shall only be permitted in accordance with Sections R505.2, R603.2 and R804.2. In accordance with the provisions of Sections R505.3.5, R603.3.4 and R804.3.5, cutting and notching of flanges and lips of cold-formed, steel-framed, load-bearing members shall not be permitted.

M1308.2 Protection against physical damage. In concealed locations where piping, other than cast-iron or galvanized steel, is installed through holes or notches in studs, joists, rafters or similar members less than 1.5 inches (38 mm) from the nearest edge of the member, the pipe shall be protected by shield plates. Protective shield plates shall be a minimum of 0.062-inch-thick (1.6 mm) steel, shall cover the area of the pipe where the member is notched or bored, and shall extend a minimum of 2 inches (51 mm) above sole plates and below top plates.

